

# HYDROGEN IN THE GAS DISTRIBUTION NETWORKS

---

*A kickstart project as an input  
into the development of a National  
Hydrogen Strategy for Australia*



COAG  
Energy Council



**GPA**  
ENGINEERING



Government  
of South Australia



## **PARTNERS**

**Prepared by GPA Engineering for the Government of South Australian in partnership with Future Fuels CRC on behalf of the COAG Energy Council.**

## **FURTHER INFORMATION**

### **Clean Energy Transition**

Department for Energy and Mining

Government of South Australia

T: + 61 8 8429 2722

E: [hydrogen@sa.gov.au](mailto:hydrogen@sa.gov.au)

[www.hydrogen.sa.gov.au](http://www.hydrogen.sa.gov.au)

## **DISCLAIMER**

The authors warrant that they have taken all reasonable care in producing this report. Although all reasonable efforts have been made to ensure quality, the Department for Energy and Mining (DEM) does not warrant that the information in this report is free from errors or omissions. DEM and its employees do not warrant or make any representation regarding the use, or results of the use, of the information contained herein as regards to its correctness, accuracy, reliability and currency or otherwise. DEM and its employees expressly disclaim all liability or responsibility to any person using the information or advice. Use of the information and data contained in this report is at the user's sole risk. If users rely on the information they are responsible for ensuring independent verification of its accuracy, currency or completeness.

## **COPYRIGHT**

This work is copyright. Apart from any use as permitted under the *Copyright Act 1968* (Cth) no part may be reproduced by any process, electronic or otherwise, without the specific written permission of the copyright owner. Neither may information be stored electronically in any form whatsoever without such permission.

# EXECUTIVE SUMMARY

In December 2018, the Council of Australian Governments (COAG) Energy Council endorsed the development of a National Hydrogen Strategy (NHS) and established a dedicated working group to take the strategy forward and report progress back to COAG. The Working Group is comprised of six work streams, of which one is *Hydrogen in the gas networks*. Under this work stream, a *kickstart* project was established to “commence work to allow up to 10% hydrogen (by volume) in the domestic gas network, both for use in place of natural gas and to provide at-scale storage for hydrogen”.

The scope of the review included investigation of technical impacts of the addition of up to 10% hydrogen into the gas networks, with the physical limits being the metered injection into and metered offtake from the distribution networks. It further included a review of technical standards, and the safety and technical regulatory framework for gas distribution networks, to identify barriers and develop recommendations to allow up to 10% hydrogen into the gas distribution networks.

A review of the impacts of addition of 10% hydrogen to a typical natural gas blend was undertaken, to understand the gas quality, materials, network capacity and blending, and safety and risk impacts to the natural gas distribution network. The review used representative gas compositions for the distribution networks in each state as the basis for calculation of the impacts of addition of 10% hydrogen to gas quality. This use of representative gas compositions for each state resulted in more realistic outcomes than a theoretical assessment alone. These impacts and considerations were then used as the basis for the technical and regulatory review.

*The review found that the addition of 10% hydrogen (by volume) to a typical natural gas blend has no significant impacts or implications on gas quality, safety and risk aspects, materials, network capacity and blending (providing the mixture is homogeneous).*

A desktop review of the standards identified as applicable to the gas distribution network was completed. The following standards were reviewed:

- AS/NZS 4645 – Gas distribution networks series;
- AS 4564 – Specification for general purpose natural gas;
- AS 2885 – Pipelines – Gas and liquid petroleum; and
- AS/NZS 60079 – Explosive atmospheres series.

Review of both the AS/NZS 4645 and AS 2885 series found that while there is nothing explicitly prohibiting the use of up to 10% hydrogen in the standard, these standards have not been written with hydrogen use in mind. Minor gaps in knowledge around network materials and safety were identified for AS/NZS 4645. The potential for hydrogen embrittlement is greater for pipelines designed under AS 2885, due to the increased pressure and higher strength steels typically applied in this service. Specific research will be required to close the knowledge gaps for higher pressure service under AS 2885. AS 4564 defines the gas quality specifications for general purpose natural gas in distribution networks, for provision of gas that is safe and suitable for using in gas burning appliances. The standard is also used in commercial contracts to define the heating value of the gas. While the typical gas compositions in each state remained within the specification limits set by AS 4564 with the addition

of 10% hydrogen (with the exception of the Northern Territory), in some cases the gas quality fell outside of the *informative* limits of the standard – however this does not represent non-compliance with AS 4564. Similar to AS/NZS 4645 and AS 2885 the standard was not written with hydrogen envisaged as a component of general purpose natural gas.

A review of AS/NZS 60079 found that it was applicable for small concentrations of hydrogen in natural gas through to pure hydrogen. However, further work is required to understand the impacts to hazardous area classification of the addition of up to 10% hydrogen into the gas blend.

*The review found that addition of up to 10% hydrogen (by volume) in the natural gas distribution networks has no significant impacts for the applicable Australian standards, but that a review of Australian standards applicable to downstream installations and appliances should also be completed to enable upscale of hydrogen injection into the gas distribution networks.*

Recommendations have been made to address gaps in technical knowledge and in current standards to remove any (minor) barriers to hydrogen injection of up to 10% hydrogen into the natural gas distribution network.

A review of the acts and regulations governing safety and technical aspects of gas distribution networks was undertaken, to understand the regulatory impacts of addition of up to 10% hydrogen into the gas distribution networks in each state. The regulatory analysis builds on early work prepared by Johnson Winter and Slattery for Energy Networks Australia.

Review of the relevant state safety and technical legislation in Queensland, South Australia, Tasmania, Victoria, and Western Australia highlighted no substantive barriers to addition of up to 10% hydrogen into the gas distribution networks, however some of the regulations reviewed also govern downstream installations and gas appliances. Regardless of the regulatory framework, gas distribution networks and downstream users are inextricably linked; in *all* states, further work is recommended to review implications to acts, regulations and standards concerned with downstream appliances and gas installations, in order to understand the implications of addition of up to 10% hydrogen into the gas networks, beyond the distribution network itself.

Despite being outside of the distribution network itself, consideration was also given to whether the legislation governing safety and technical aspects of gas distribution networks allows for regulation of the hydrogen production facility upstream of the network. It is recommended that a review of the applicable regulatory framework for hydrogen production facilities in each state be undertaken, with a view to identifying opportunities for development of consistent principles across state regulations, and that this work be undertaken in parallel with development of a technical framework of Australian or international standards for hydrogen production facilities.

*The review found that addition of up to 10% hydrogen (by volume) to the gas distribution networks has no significant implications for the applicable Australian state legislation, but that a review of legislation covering downstream installations and appliances should also be completed.*

While the national gas market regulatory framework was outside the scope of this review, a broad assessment of the impact of blending 10% hydrogen on the National Gas Law and National Gas Rules was contributed by South Australian Government's Department for Energy and Mining. While the review found that there is nothing directly prohibiting the blend of 10% hydrogen into existing gas distribution networks, it also considered whether the regulatory framework would continue to apply as intended. The review found that there is uncertainty about whether the definition of natural gas captures blended gas; what impact blending has on the operation of the existing framework; and to what extent the existing framework applies to blended gas. Therefore, it is recommended that consideration be given to amending the National Gas Law and National Gas Rules to provide certainty on how these will apply and operate with blended gas in the distribution network.

*The review of the national gas market regulatory framework by the Department for Energy and Mining of the South Australian Government found that amendments may be required to provide certainty on how the framework will operate with blended gas including up to 10% hydrogen (by volume).*

On completion of the technical, standards and regulatory review, a set of clear recommendations were developed addressing each aspect and the suite of potential barriers identified. These recommendations, and proposed timeframes for their implementation, are outlined in further detail in section 7 of this report.

*Sixteen recommendations have been made to address the minor potential barriers for broad scale injection of hydrogen of up to 10% hydrogen (by volume) into the natural gas distribution networks.*

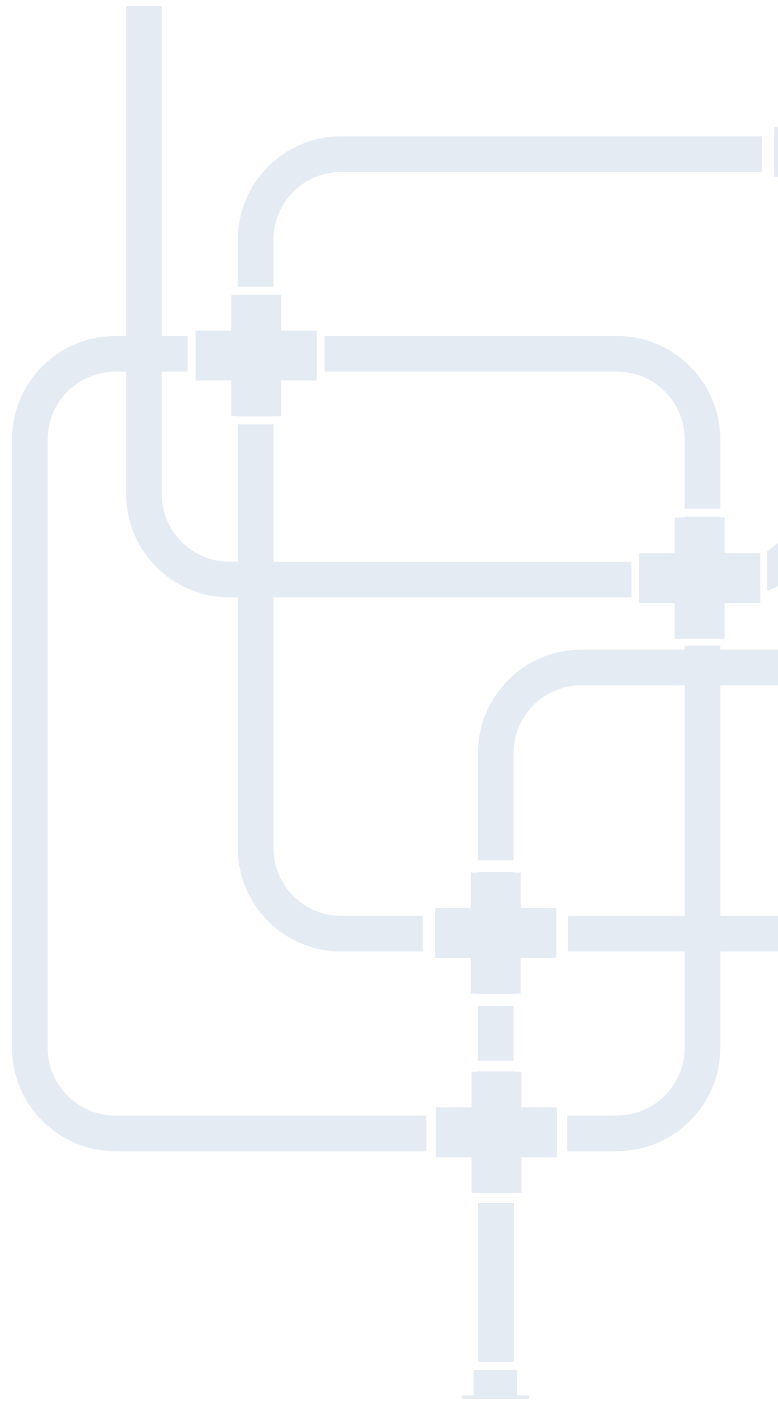

Topic	Recommendation(s)
AS/NZS 4645	Complete a detailed review and update of the AS/NZS 4645 series for compatibility of hydrogen up to 10% hydrogen (by volume), including referenced standards.
AS 4564	<p>AS 4564 should be revised with the following in mind:</p> <ul style="list-style-type: none"> <li>• Definition and intended application of natural gas reviewed and updated;</li> <li>• Expected Range of HHV found in Table 3.1 note 5 reviewed and updated; and</li> <li>• Expected Range of relative density found in Table 3.1 note 6 reviewed and updated.</li> </ul>
AS 2885 (for distribution network application)	<p>AS 2885 should be reviewed with respect to hydrogen and modifications to the standard should be completed or a code of practice for hydrogen developed in the interim period before the next formal revision. This will also require input from researchers to close the knowledge gaps.</p> <p>It is also recommended that hydrogen is added explicitly as a fluid similar to how carbon dioxide is included in the standard series.</p>
Downstream installations and appliances	Undertake a technical and regulatory review of the impacts of addition of 10% hydrogen on downstream installations and appliances.
Feedstock users	A scoping study followed by a technical, commercial and regulatory review of impacts of up to 10% hydrogen (by volume) to feedstock users that use natural gas in a process should be completed.
MESG	Undertake a literature review to identify whether research or testing has previously been completed to confirm MESG.
Injection and blending	A blueprint for injection and blending should be developed to assist network operators to manage their networks so that 10% hydrogen (by volume) is not exceeded at appliances.
Aged plastic piping	Complete a literature review and, if required, further investigate the impacts of hydrogen, both technical and commercial, to aged plastic piping systems (including suitability of elastomer seals) installed in the gas distribution network.
Pressure cycling	A review of network operating flow conditions for distribution networks designed to AS 2885 should be completed. If significant pressure cycling is found further investigation of the impacts of pressure cycling in distribution networks should be completed in the form of a literature review.
Network materials review	Develop a detailed database of network materials and establish an assessment program for hydrogen suitability.
Gas metering and measurement devices	Review the technical and commercial suitability of gas measurement devices installed in the distribution network, for the addition of up to 10% hydrogen.

Topic (Cont)	Recommendation(s) (cont)
Gas detection devices	A review of the technical suitability of gas detection equipment installed and used in the distribution network for up to 10% hydrogen should be completed.
Hydrogen production and delivery facilities	A review of the regulatory framework (including technical standards) for hydrogen production facilities should be undertaken, with consideration given to opportunities to develop consistent principles for regulation across all states.
State legislation	Consideration should be given to development of a legal framework in the Australian Capital Territory that would allow for regulation of hydrogen in the gas distribution networks.
State legislation	Consider development of a framework for the regulation of hydrogen in the gas distribution network in NSW. This could include a regulation that prescribes either hydrogen or a blend of hydrogen in natural gas as gas, for the purposes of the Gas Supply Act 1996 (NSW).
National gas market regulatory framework	Consideration should be given to amendments to the national gas market regulatory energy framework to provide for regulation of hydrogen in the gas distribution networks.

Generally, the knowledge gaps identified can be addressed with current research and projects being completed domestically and internationally. Pilot facilities and research organisations should be leveraged, where possible, to develop further knowledge.

Areas for further work covering aspects that were not included in the scope of this report were identified as a logical progression from the work undertaken to date. In particular, consideration should be given to undertaking a technical, regulatory and commercial review of introduction of hydrogen into the gas transmission lines, and to the addition of greater than 10% hydrogen into the gas distribution networks.

Finally, recommendations that are applicable and best facilitated by other work streams under the National Hydrogen Strategy were identified.

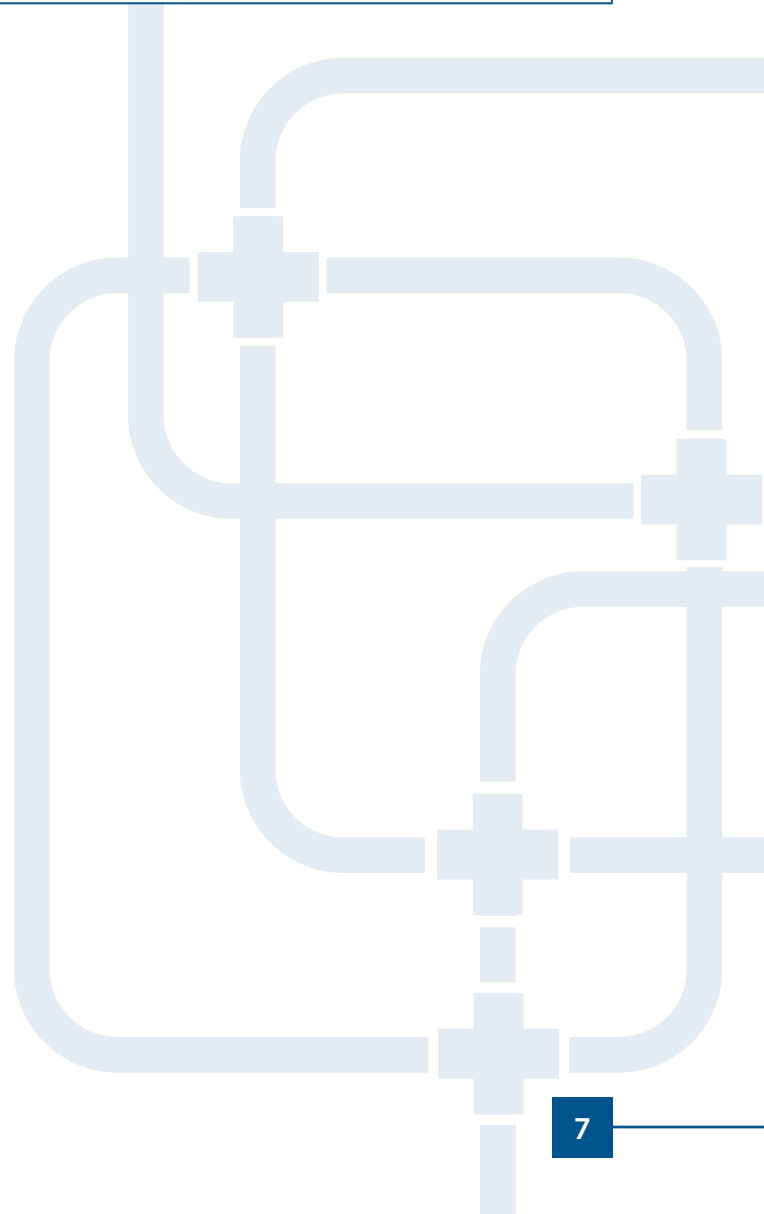

# CONTENTS

<b>1</b>	<b>INTRODUCTION</b>	<b>12</b>
1.1	Background	12
1.2	Scope and limitations	12
1.3	Definitions	14
1.4	Abbreviations	15
<b>2</b>	<b>UNDERSTANDING THE GAS NETWORKS</b>	<b>16</b>
2.1	Natural gas supply chain	16
2.2	Gas market	16
2.3	Production	17
	2.3.1 <i>Recommendation for hydrogen production facilities</i>	19
2.4	Transmission network	19
2.5	Distribution network	20
	2.5.1 <i>Standards and regulations</i>	20
	2.5.2 <i>Distribution network ownership</i>	20
	2.5.3 <i>Network operating pressures</i>	22
	2.5.4 <i>Network materials</i>	24
	2.5.5 <i>Composition</i>	25
	2.5.6 <i>Town gas</i>	25
2.6	End-user	26
	2.6.1 <i>Downstream installations and appliances</i>	26
	2.6.2 <i>Feedstock for a production process</i>	31
2.7	Retailer	32
2.8	Summary of existing gas network considerations	33
<b>3</b>	<b>PROJECTS, PREVIOUS STUDIES AND CURRENT RESEARCH</b>	<b>35</b>
3.1	Australian injection pilot projects	35
3.2	International projects	36
	3.2.1 <i>HyDeploy</i>	36
	3.2.2 <i>H21 Leeds City Gate and H21 North of England</i>	37
3.3	Research and programs	37
	3.3.1 <i>Future Fuels Cooperative Research Centre (FFCRC)</i>	37
	3.3.2 <i>CSIRO – National Hydrogen Roadmap</i>	38
	3.3.3 <i>Australian Renewable Energy Agency (ARENA)</i>	38
3.4	Summary of projects, studies and research	39



<b>4</b>	<b>IMPACTS AND KEY CONSIDERATIONS</b>	<b>40</b>
<b>4.1</b>	<b>Gas quality</b>	<b>40</b>
4.1.1	<i>Gas composition</i>	40
4.1.2	<i>Higher heating value</i>	41
4.1.3	<i>Specific Gravity</i>	42
4.1.4	<i>Wobbe Index</i>	42
4.1.5	<i>Methane Number</i>	43
4.1.6	<i>Flame speed factor</i>	43
4.1.7	<i>Sooting Index</i>	43
4.1.8	<i>Flammability limit</i>	44
4.1.9	<i>Flame emissivity</i>	44
4.1.10	<i>Joule-Thomson coefficient</i>	45
4.1.11	<i>Minimum ignition energy</i>	45
4.1.12	<i>Auto ignition temperature</i>	46
4.1.13	<i>Moisture vapour</i>	46
<b>4.2</b>	<b>Network injection, capacity and blending</b>	<b>46</b>
4.2.1	<i>Network capacity</i>	46
4.2.2	<i>Injection location, mixing and production variability</i>	47
4.2.3	<i>Gas mixture stratification in pipelines</i>	48
4.2.4	<i>Measurement and metering of gas</i>	48
<b>4.3</b>	<b>Network construction materials</b>	<b>49</b>
4.3.1	<i>Plastic piping</i>	49
4.3.2	<i>Carbon steel piping systems</i>	51
4.3.3	<i>Cast iron</i>	53
4.3.4	<i>Copper piping systems</i>	54
<b>4.4</b>	<b>Safety and risk</b>	<b>54</b>
4.4.1	<i>Hazardous area</i>	55
4.4.2	<i>Worker safety</i>	55
4.4.3	<i>Gas detection</i>	56
4.4.4	<i>Gas build-up in buildings</i>	57
4.4.5	<i>Air dilution rates in enclosed spaces</i>	58
4.4.6	<i>Radiation and dispersion distance</i>	58
4.4.7	<i>Odourisation</i>	59
<b>4.5</b>	<b>Summary of key considerations for regulations &amp; standards</b>	<b>60</b>

<b>5</b>	<b>IMPLICATIONS FOR AUSTRALIAN STANDARDS</b>	<b>64</b>
5.1	<b>AS/NZS 4645 series – gas distribution networks</b>	<b>64</b>
5.1.1	<i>Current Distribution Network Methodology</i>	64
5.1.2	<i>Specific Considerations for Hydrogen</i>	65
5.1.3	<i>Recommendation for AS/NZS 4645</i>	67
5.2	<b>AS 4564 – specification for general purpose natural gas</b>	<b>68</b>
5.2.1	<i>Purpose and methodology</i>	68
5.2.2	<i>Development of AS 4564</i>	69
5.2.3	<i>Specific considerations for hydrogen</i>	69
5.2.4	<i>Recommendations for AS 4564</i>	72
5.3	<b>AS 2885 – pipelines – gas and liquid petroleum</b>	<b>73</b>
5.3.1	<i>Impacts of hydrogen to pipeline design</i>	74
5.3.2	<i>Current Hydrogen Pipeline Design Methodology</i>	74
5.3.3	<i>Specific considerations for hydrogen</i>	75
5.3.4	<i>Application of AS 2885</i>	79
5.3.5	<i>Recommendation for AS/NZS 2885</i>	80
5.4	<b>AS/NZS 60079 – explosive atmospheres series</b>	<b>81</b>
5.4.1	<i>Current hazardous area methodology</i>	82
5.4.2	<i>Considerations for hydrogen</i>	82
5.4.3	<i>Areas for development and further research</i>	83
5.4.4	<i>Recommendations for AS 60079</i>	83
5.5	<b>Summary of implications for Australian standards</b>	<b>84</b>
<b>6</b>	<b>IMPLICATIONS FOR AUSTRALIAN STATE REGULATIONS</b>	<b>86</b>
6.1	<b>Australian capital territory</b>	<b>86</b>
6.2	<b>New South Wales</b>	<b>87</b>
6.2.1	<i>Gas Supply Act 1996</i>	87
6.2.2	<i>Gas Supply (Safety and Network Management) Regulation 2013</i>	88
6.3	<b>Northern Territory</b>	<b>90</b>
6.4	<b>Queensland</b>	<b>91</b>
6.4.1	<i>Petroleum and Gas (Production and Safety) Act 2004</i>	91
6.4.2	<i>Petroleum and Gas (General Provisions) Regulation 2017</i>	92
6.4.3	<i>Petroleum and Gas (Safety) Regulation 2018</i>	92
6.5	<b>South Australia</b>	<b>94</b>
6.5.1	<i>Gas Act 1997</i>	94
6.5.2	<i>Gas Regulations 2012</i>	95
6.6	<b>Tasmania</b>	<b>97</b>
6.6.1	<i>Gas Act 2000</i>	97
6.6.2	<i>Gas Safety Regulations 2014</i>	98

6.7	<b>Victoria</b>	<b>99</b>
6.7.1	<i>Gas Safety Act 1997</i>	99
6.7.2	<i>Gas Safety (Safety Case) Regulations 2018</i>	100
6.8	<b>Western Australia</b>	<b>101</b>
6.8.1	<i>Gas Standards Act 1972</i>	101
6.8.2	<i>Gas Standards (Gas Supply and System Safety) Regulations 2000</i>	102
6.9	<b>Recommendations for state legislation</b>	<b>105</b>
6.10	<b>National Gas Market Regulatory Framework</b>	<b>106</b>
6.10.1	<i>Implications for the National Gas Market Regulatory Framework</i>	106
6.10.2	<i>National Gas Law (NGL) and National Gas Rules (NGR)</i>	106
6.10.3	<i>National Energy Retail Law (NERL) and National Energy Retail Rules (NERR)</i>	108
6.10.4	<i>Implications for the National Regulatory Framework</i>	109
6.10.5	<i>Recommendation for national gas market regulatory framework</i>	112
6.11	<b>Summary of implications for regulations</b>	<b>113</b>
<b>7</b>	<b>RECOMMENDATIONS AND AREAS FOR INVESTIGATION</b>	<b>117</b>
7.1	<b>Summary of recommendations</b>	<b>117</b>
7.2	<b>Areas of further interest</b>	<b>117</b>
7.2.1	<i>Transmission networks</i>	117
7.2.2	<i>Concentrations exceeding 10% hydrogen</i>	126
7.3	<b>Recommendations for other work streams</b>	<b>126</b>
7.3.1	<i>Feedstock users</i>	126
7.3.2	<i>Hydrogen production and delivery facilities</i>	126
<b>8</b>	<b>ACKNOWLEDGEMENTS</b>	<b>127</b>
8.1	<b>Lead authors</b>	<b>127</b>
8.2	<b>Contributors</b>	<b>127</b>
8.3	<b>Working group</b>	<b>127</b>
<b>9</b>	<b>REFERENCES</b>	<b>129</b>
	<b>APPENDIX 1 DISTRIBUTION NETWORK OWNERSHIP SUMMARY</b>	<b>132</b>
	<b>APPENDIX 2 GAS PROPERTIES CALCULATION</b>	<b>134</b>
	<b>APPENDIX 3 PRESSURE REDUCTION CALCULATION</b>	<b>142</b>
	<b>APPENDIX 4 FEEDSTOCK PROCESSES</b>	<b>148</b>

# 1 INTRODUCTION

## 1.1 Background

In 2017, the Australian hydrogen strategy group released *Hydrogen for Australia's future* which highlights the opportunities for hydrogen into the future.<sup>1</sup> The paper identified hydrogen as having the potential to decarbonise our energy sector, provide new opportunities in the transport sector, and create a market for export. It also identified that a key advantage of hydrogen as a fuel alternative is the ability to use existing natural gas infrastructure as an energy storage and distribution system with minimal retrofit.<sup>2</sup>

In 2018, the Council of Australian Government (COAG) Energy Council committed to a vision of making Australia a major player in the global hydrogen industry by 2030. To implement this decision it endorsed the development of a National Hydrogen Strategy (NHS). As part of this strategy, a working group was formed which is comprised of six work streams:

1. Developing a hydrogen export industry;
2. Hydrogen in the gas networks;
3. Hydrogen for transport
4. Hydrogen to support electricity systems;
5. Hydrogen for industrial users; and
6. Cross cutting issues.

The scope of the *hydrogen in the gas networks* working group is to propose how to transition and maximise the potential use of hydrogen to the long term goal of 100% in the natural gas network.

An initial target of 10% hydrogen (by volume) in distribution networks was selected based on an assumption that a gradual move to this target was considered achievable with no significant impact on distribution infrastructure or consumer appliances

---

1 (The Hydrogen Strategy group, 2018)

2 (The Hydrogen Strategy group, 2018)

and with a low impact on prices.<sup>3</sup> As a first step the NHS endorsed a kickstart project to “commence work to allow up to 10% hydrogen in the domestic gas network, both for use in place of natural gas and to provide at-scale storage for hydrogen”.

The kickstart project was led by the South Australian Department for Energy and Mining (DEM) in conjunction with Future Fuels Cooperative Research Centre (FFCRC), on behalf of the COAG Energy Council. Under the project, GPA Engineering was engaged to deliver a report reviewing the technical and regulatory barriers to addition of up to 10% hydrogen (by volume) to existing gas distribution networks.

## 1.2 Scope and limitations

The objective of this study was to identify technical and regulatory barriers to allowing injection of up to 10% hydrogen (by volume) into Australian natural gas distribution networks.

A desktop review of the natural gas distribution networks in Australia and a high level summary of typical network configuration were completed. This would provide background information on the networks. The review included a desktop review of previous research and pilot projects, both domestically and internationally.

A review of commercial considerations and impacts to processes feedstock users was undertaken by Future Fuels Cooperative Research Centre (FFCRC) and the South Australian Government Department of Energy and Mining respectively along with input from industry.

This report included a review of the impacts of addition of up to 10% hydrogen (by volume) into Australian natural gas distribution network based on

---

3 (The Hydrogen Strategy group, 2018)



previous research and case studies. A summary of key considerations for use of up to 10% hydrogen (by volume) mixtures in a gas network was then prepared.

A review was completed of the relevant Australian standards, gas safety regulations, and gas technical distribution regulations against the impacts of addition of up to 10% hydrogen (by volume) to the current natural gas. Additionally, a high level review of implications to the national gas market regulatory framework was undertaken by the South Australian Government Department of Energy and Mining. From these reviews the barriers that are currently limiting or prohibiting the utilisation in the gas distribution network were identified.

The report then provided recommendations to remove the barriers identified in the technical standards, national gas market regulatory framework, gas technical regulation, and gas safety regulation and highlight areas where more work is required.

Finally, the report highlights any cross-cutting issues that could impact other working streams and areas for further investigation that were not explicitly part of the scope but were identified during the study.

The study assumes a limit of 10% hydrogen (by volume) in natural gas. Consideration is given to excursions above a limit of 10% hydrogen (by volume), but higher concentrations of hydrogen are excluded from this study. It should be noted that anticipated satisfactory performance and compliance of distribution networks with levels up to 10% hydrogen (by volume) does not imply that the concentration can be increased above 10% (by volume) without issue. As part of the recommendations made, further technical and regulatory investigation should be completed with higher concentrations considered.

Impacts to downstream gas appliances were not explicitly within the scope of this project. However as downstream impacts and distribution network impacts are integrally linked, impacts to appliances have been considered in section 2.6.

The use of hydrogen in the existing upstream high pressure transmission system was excluded from the scope of this kickstart project, due to the increased risk of hydrogen embrittlement for higher grade pipelines operating at higher pressure.<sup>4</sup>

For the purpose of this study, all modelling requiring standard conditions has been completed using the definition outlined in *AS 4564:2011 – Specification for General Purpose Natural Gas*.<sup>5</sup> Standard conditions for gas properties; for billing and measurement purposes in the Australian gas networks are 101.325 kPag and 15°C.

The physical limit of the scope of this study was restricted to the Australian natural gas distribution network bounded by:

- a. Metered injection points into the a distribution network; and
- b. Metered offtake points from the distribution network.<sup>6</sup>

The review of implications to Australian regulations was limited to the safety and technical legislation relevant to gas distribution networks.

Regulation of hydrogen production facilities was outside the scope of the review.

---

4 (EPCRC, 2017)

5 (Standards Australia - AS 4564, 2011)

6 This is located at the edge of the transition from the distribution to the appliance. For low pressure application is generally on the appliance user's property.

## 1.3 Definitions

The following definitions are applied as part of this report:

**Table 1** *Definitions*

Item	Definition
Gas exchangeability	The ability to commingle or exchange natural gases from different sources for use of this commingled mixture in various applications including industrial engines, gas turbines, gas appliances and in feedstock applications without material change in operational safety, performance and efficiency, and within an acceptable variation in the air pollution.
10% hydrogen	For the purpose of this report hydrogen concentration in natural gas will be considered for a maximum of up to 10% (by volume). Except where it is explicitly stated otherwise.
Inert gas	Any material that exists predominantly in a gaseous state at standard conditions, and which does not contribute to energy release when the gas burns. Inert gases include, but are not limited to, carbon dioxide, nitrogen, oxygen and noble gases.
Limit	The value beyond which the specified characteristic or concentration of the component shall not be permitted to vary.
Location Class	Classification of an area according to its predominant land use and density of human activity, reflecting both the threats to the pipeline system from the land usage and the consequences for the population, should the pipeline system suffer a loss of containment.*
Measurement Length (Radiation Contour)	The radiation contour is the radius of the thermal heat flux radiation zone resulting from an ignited rupture on a gas pipeline. The critical contour is a radius of 4.7 kW/m <sup>2</sup> , which is the thermal radiation value likely to cause severe injury. The measurement length is used to determine the pipeline location class.†
Natural gas	A gaseous fuel consisting of a mixture of hydrocarbons of the alkane series, primarily methane but which may also include ethane, propane and higher hydrocarbons in smaller amounts. It may also include some inert gases, plus minor amounts of other constituents including odorizing agents. Natural gas remains in the gaseous state under the temperature and pressure conditions normally found in service.‡
NO <sub>x</sub>	NO <sub>x</sub> is a generic term for the nitrogen oxides that are most relevant for air pollution, namely nitric oxide (NO) and nitrogen dioxide (NO <sub>2</sub> )
Off-specification gas	Gas, which does not comply with the gas quality specifications for that system injection point.
Total sulphur	Sulphur from all sources including odorisation of the gas.

\* (Standards Australia - AS 2885.0, 2018) Section 1.5.37

† (Standards Australia - AS 2885.0, 2018) Section 1.5.41

‡ (Standards Australia - AS 4564, 2011) Section 1.6.6

## 1.4 Abbreviations

The following abbreviations have been used as part of this project:

**Table 2**     *Abbreviations*

Abbreviation	Description
AEMC	Australian Energy Market Commission
AEMO	Australian Energy Market Operator
AER	Australian Energy Regulator
AGIG	Australian Gas Infrastructure Group
AGN	Australian Gas Network
AS	Australian Standard
ASME	American Society of Mechanical Engineers
CDL	Critical defect length
COAG	Council of Australian Governments
CNG	Compressed Natural Gas
CSG	Coal Seam Gas
DEM	Department of Energy and Mining
DLE	Dry Low Emissions
DLN	Dry Low NOx
DN	Diameter Nominal
ENA	Energy Networks Australia
EPCRC	Energy Pipelines Cooperative Research Centre
ERA	Economic Regulation Authority
FFCRC	Future Fuels Cooperative Research Centre
FSA	Formal Safety Assessment
GC	Gas Chromatograph
GE	General Electric
GGP	Goldfields Gas Pipeline
GT	Gas Turbine
GTI	Gas Technology Institute
HAC	Hydrogen assisted cracking
HDPE	High density polyethylene
HHV	Higher Heating Value
ILI	In-Line Inspection
ISO	International Standards Organisation
JGN	Jemena Gas Network

Abbreviation	Description
JT	Joules-Thomson
kW	Kilowatt
LEL	Lower Explosive Limit
LFL	Lower Flammability Limit
LNG	Liquefied Natural Gas
LPG	Liquefied Petroleum Gas
MAOP	Maximum Allowable Operating Pressure
MAPS	Moomba to Adelaide Pipeline System
MESG	Maximum Experimental Safe Gap
MPa	Megapascals
MRP	Mains Replacement Program
MHF	Major Hazard Facility
MIC	Minimum Ignition Current
MIE	Minimum Ignition Element
MW	Megawatt
NHS	National Hydrogen Strategy
NZS	New Zealand Standard
OEM	Original Equipment Manufacturer
PA	Polyamide
PE	Polyethylene
PEM	Proton Exchange Membrane
PGC	Process Gas Chromatograph
PTFE	Polytetrafluoroethylene
PVC	Polyvinyl chloride
SAOP	Safety and Operating Plan
SBR	Styrene-butadiene rubber
SMYS	Specified Minimum Yield Stress
UEL	Upper Explosive Limit
UFL	Upper Flammability Limit
UK	United Kingdom
UV	Ultra Violet
WHS	Work Health and Safety
WI	Wobbe Index

# 2 UNDERSTANDING THE GAS NETWORKS

## 2.1 Natural gas supply chain

The Australian natural gas network is a complex system; with operating procedures, materials, and operating conditions all varying from state to state. The natural gas supply chain in Australia is comprised of:

- Gas market – Regulates the buying and selling of natural gas;
- Production – Extract the gas from underground reservoirs and remove heavy hydrocarbons and impurities from natural gas for supply to natural gas transmission networks;
- Transmission – Transports natural gas along high pressure pipelines over long distances from (typically) isolated production facilities to supply the natural gas distribution network. The transmission network also supplies major industrial users;
- Distribution – Supplies natural gas through a network of lower pressure distribution pipelines. These are located in towns and cities around Australia and vary significantly from network-to-network;
- Retailers – Sell the natural gas provided by the distribution pipeline operators to individual consumers; and
- End-users – Individual premises, business and household consumers who use the gas.

Figure 1 identifies the jurisdiction of the various standards that apply across gas networks.

## 2.2 Gas market

This gas market is governed by a national regulatory framework, which comprises of:

- The National Gas Law (NGL),
- The National Gas Rules (NGR),
- The National Energy Retail (NER) Law,
- The National Energy Retail Rules (NERR) and supporting regulations.

The Australian Energy Market Commission (AEMC) regulates the National Gas Rules, which apply to wholesale gas markets. The Australian Energy Market Operator (AEMO) operates retail and wholesale gas markets across Australia while the Australian Energy Regulator (AER) oversees the gas markets in Western Australia.

Gas markets in Australia are comprised of three separate regions, the Western Australian region covering Western Australia (WA), the East Coast region, covering Queensland, South Australia (SA), New South Wales (NSW), Victoria, Tasmanian and the Australian Capital Territory (ACT) and the Northern Region covering the Northern Territory (NT). All three regions provide gas to the domestic market as well as sell to international customers via liquefied natural gas (LNG) export facilities.

The East Coast gas region is an interconnected market with pipelines joining the five states and the ACT, and connected to the Northern Region, near Mount Isa, following the completion of Jemena's Northern Gas Pipeline.



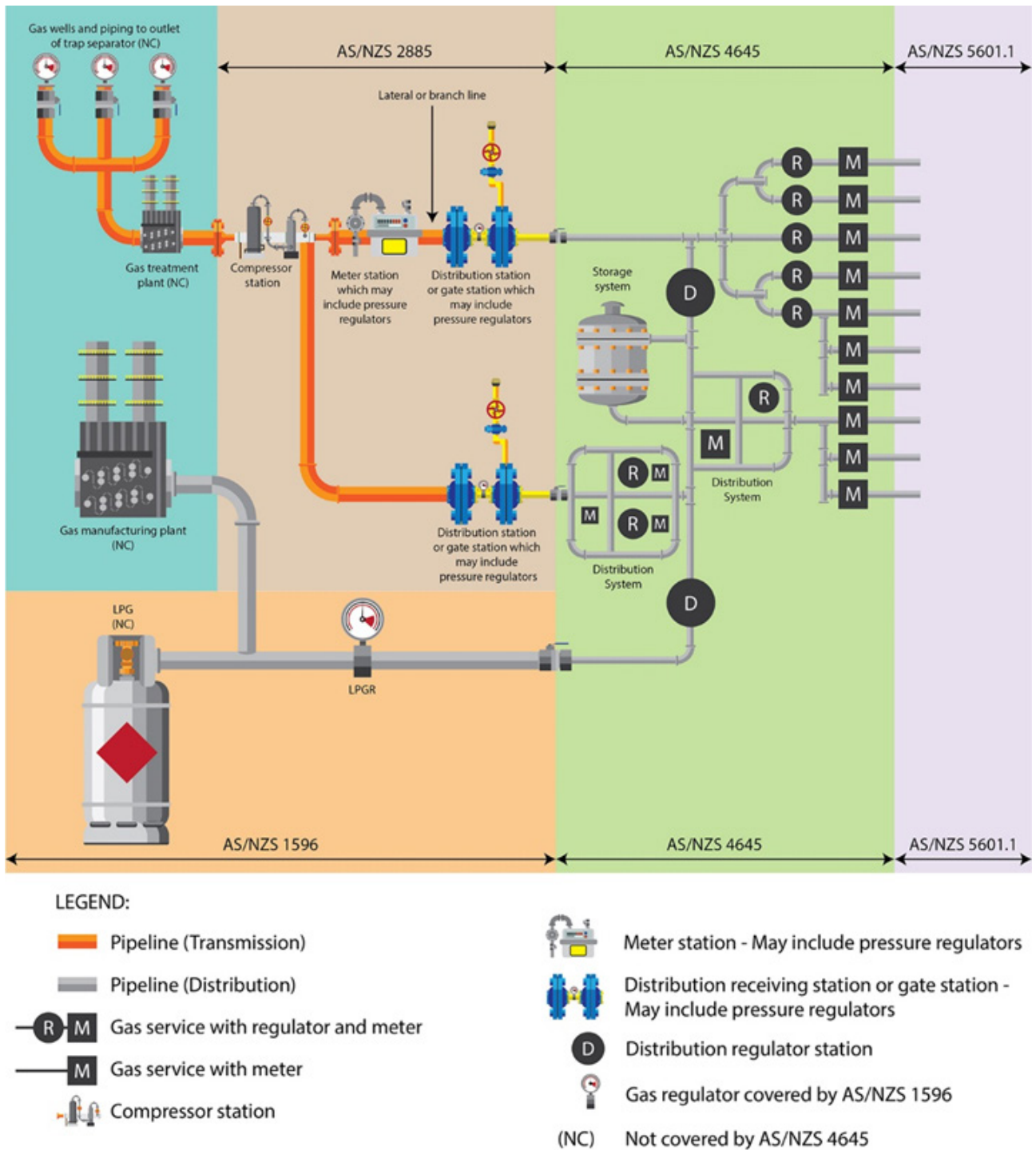
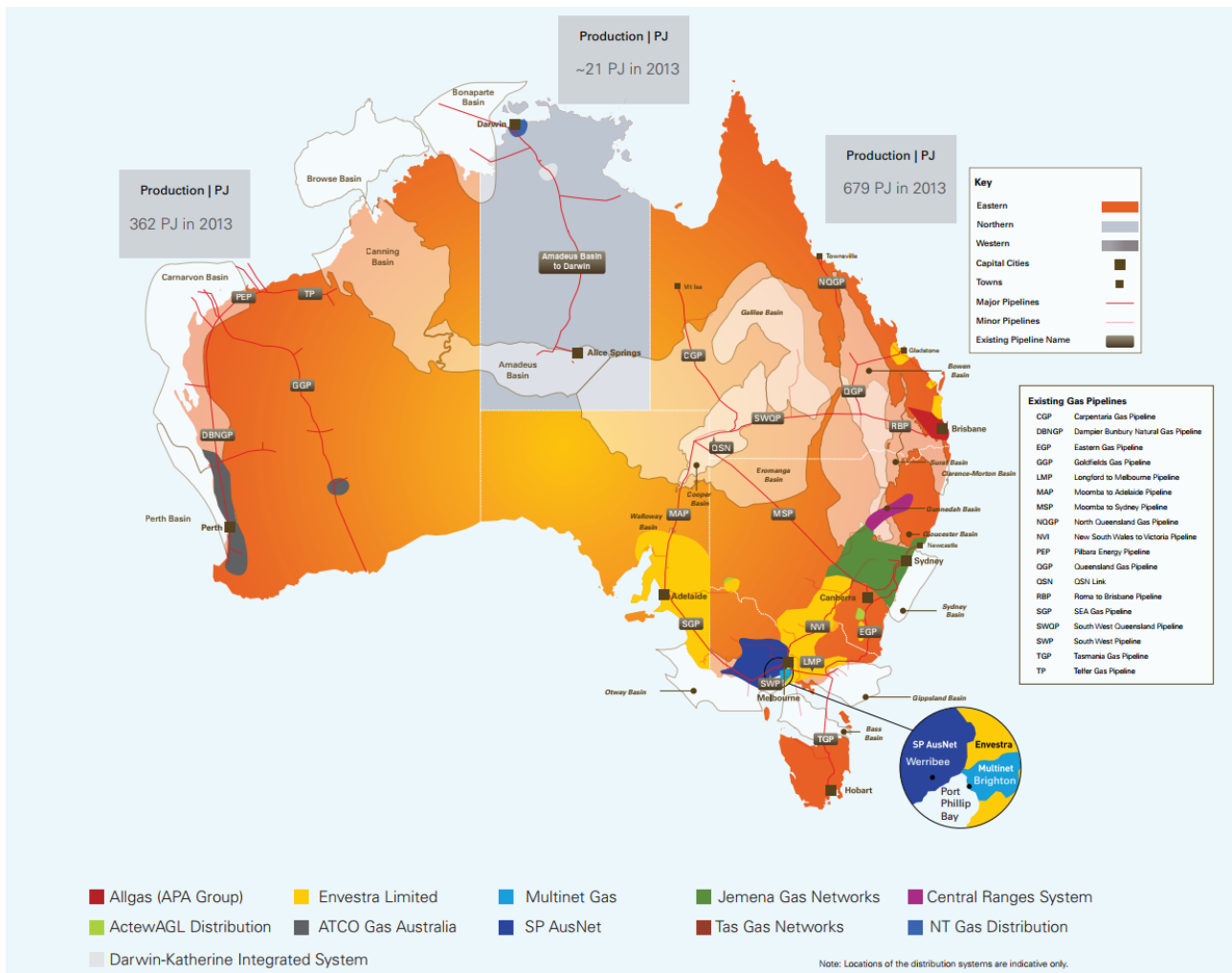

Figure 1 Natural Gas Supply Chain and relevant standards.  
 (Revised from Standards Australia - AS/NZS 4645, 2011)

## 2.3 Production

Natural gas in Australia is supplied from conventional and non-conventional gas in reserves, which can be found both onshore and offshore.

The sources of conventional natural gas in eastern Australia include the Cooper/Eromanga Basin, the Otway Basin, the Bass Basin and the Gippsland Basin. Coal seam methane fields have also been discovered in Camden, the Hunter Valley, the Bowen Basin, the Surat Basin, the Adavale Basin and the Clarence Moreton



**Figure 2 Gas Infrastructure, Regional Gas Markets and Major Supply Basins**

(Energy Networks Australia, 2014; Since publication of this map Envestra has been rebranded as Australian Gas Networks. ActewAGL has changed name to Evoenergy.)

Basin. Within each of these basins there are a number of gas fields currently producing conventional natural gas or coal seam methane.

The Northern Territory produces gas from the Amadeus Basin and the Bonaparte Basin.

The gas basins of the western gas market contain over half of Australia’s gas reserves, and include the primarily offshore Carnarvon, Perth, Bonaparte, and Canning Basins. This market is heavily focussed on exports but also supplies domestic consumption in Western Australia.

Currently, gas production is regulated state-by-state. In several states, regulations that apply to production,

transmission and distribution facilities for natural gas, generally apply to naturally occurring hydrocarbons and do not include other fuels such as hydrogen within their scope of application.

Hydrogen production facilities are regulated under Work Health and Safety (WHS) legislation and, depending on production levels, potentially defined as a Major Hazard Facility (MHF). Regulation of small hydrogen production facilities<sup>7</sup> that are below the threshold quantities that would require classification as a MHF is under WHS legislation.

<sup>7</sup> For example hydrogen refueling facilities with on-site hydrogen production

### 2.3.1 Recommendation for hydrogen production facilities

For regulation of hydrogen production for the purpose of injection into the gas distribution networks, it is recommended that consideration be given to how the existing state regulatory frameworks could be amended to allow for hydrogen production facilities. It is further recommended that a coordinated review of the potential to develop consistent principles for regulation across all states be undertaken.

To support the regulatory framework, technical standards are required to ensure facilities are designed and operated safely. There are no current Australian standards for hydrogen production technology, such as electrolyzers. Although international standards exist they have not yet been adopted. Standards Australia facilitated a forum in October 2018, which recommended Australia become a participating member of ISO/TC 197, Hydrogen Technologies, and the adoption of ISO 14687 and ISO 22734, Parts 1 and 2. Technical committee ME-093 Hydrogen Technologies is currently being constituted as a mirror committee to ISO/TC 197.

*It is recommended that a review of the regulatory framework (including technical standards) for hydrogen production facilities be undertaken, with consideration given to opportunities to develop consistent principles for regulation across all states. This recommendation is intended to develop a clear regulatory pathway for development of hydrogen production facilities, particularly in relation to injection into the gas distribution networks. This is a medium term action as there*

*are currently alternative pathways to the development of production facilities, however opportunity exists for streamlining regulation. It is expected that this recommendation will be driven by both industry and government.*

## 2.4 Transmission Network

Transmission pipelines transport natural gas from processing or storage facilities over long distances to domestic markets. In Australia, there is an interconnected pipeline network covering Queensland, New South Wales, Victoria, South Australia, Tasmania, the Australian Capital Territory and the Northern Territory. Transmission pipelines in Western Australia are not interconnected with other jurisdictions.

Australian transmission pipelines are designed, constructed, tested and operated to the AS 2885 – Pipelines – Gas and Liquid Petroleum series.<sup>8</sup> These pipelines typically:

- have larger diameters (generally >300mm)
- operate under high pressure (generally 10-15MPa)
- are constructed using high strength carbon steels (yield strengths generally 290 to 485 MPa)
- operate under high stress, up to 72-80% of the specified minimum yield strength (SMYS)

The potential of transmission networks to store and transport bulk quantities of hydrogen is an opportunity for future hydrogen production.

The Australian transmission network includes significant pipelines, critical to supply, constructed before 1970 and have little tolerance to a reduction in toughness due to their existing material properties. Sections of the transmission network are also more likely to be subject to greater pressure fluctuations, compared

<sup>8</sup> (Standards Australia - AS 2885.0, 2018)

to distribution networks, particularly for transmission pipelines used for storage or supply to peaking power stations. Pipelines in these installations consequently have less tolerance to loss of fatigue life.

The potential for a 10% hydrogen blend or higher on the natural gas transmission network is an area of future interest that will require close engagement with domestic and international research being conducted. Until a greater body of knowledge is developed on the impact of hydrogen on transmission pipeline materials, the use of hydrogen in transmission networks will be limited and require assessment on a case by case basis.

Although review of the higher pressure transmission networks is outside the scope of this report, the investigation of regulatory barriers for transmission networks is proposed to be assessed in a FFCRC research project, RP2.2-01. The impact of hydrogen on transmission pipeline materials is also proposed to be investigated under FFCRC Program 3, commencing with a detailed literature study under project RP3.1-01.

## 2.5 Distribution Network

The distribution network, the focus of this study, is comprised of a collection of piping systems, which deliver gas from the transmission network to the end-user e.g. a domestic customer.

### 2.5.1 Standards and regulations

Domestic natural gas networks are governed by the National Gas Law and Rules administered by the Australian Energy Regulator (AER) in eastern Australia, and the Economic Regulation Authority (ERA) in Western Australia. These regulators set the reference tariffs for gas distributors.

In Australia design, construction, testing and operation of gas distribution systems must comply with the relevant standards and regulations. The standards that are followed during the design and construction of a gas distribution network are:

- AS 2885 – Pipelines – Gas and Liquid Petroleum
- AS/NZS 4645 Series – Gas Distribution Networks – Parts 1, 2, and 3

- AS/NZS 4809 – Copper Pipes
- AS 4564 – Specification for Natural Gas

AS/NZS 5601.1 is the design standard for the piping system between the consumer billing meter to the appliance. AS/NZS 5601.1 is referenced in AS/NZS 4645, and although not directly relevant to the distribution network, should be considered during this review.

### 2.5.2 Distribution network ownership

Gas distribution networks exist in each state and territory of Australia centred in capital cities, major regional centres and towns. The distribution network is extensive and supplies gas to over 5 million connections through 97,000km of piping.<sup>9</sup>

Figure 3 provides the natural gas use by state in 2016, separated into residential and commercial, and industrial use. The analysis does not include remote gas networks, networks to transport gas for export or the Northern Territory.

The market is dominated by a handful of Gas Distribution Businesses operating in each state, with some companies, such as Australian Gas Networks (AGN), operating in multiple jurisdictions. Figure 4 gives a summary of the installed customers, energy supply and kilometres installed by Gas Distribution.

Appendix 1 gives a summary of the Gas Distribution Businesses across Australia.

There is also a number of isolated LPG networks in operation. Examples of these systems are Margaret River, Leinster, Falls Creek, Albany and Hopetown, which have reticulated LPG.

---

<sup>9</sup> (Energy Network Australia, 2019)



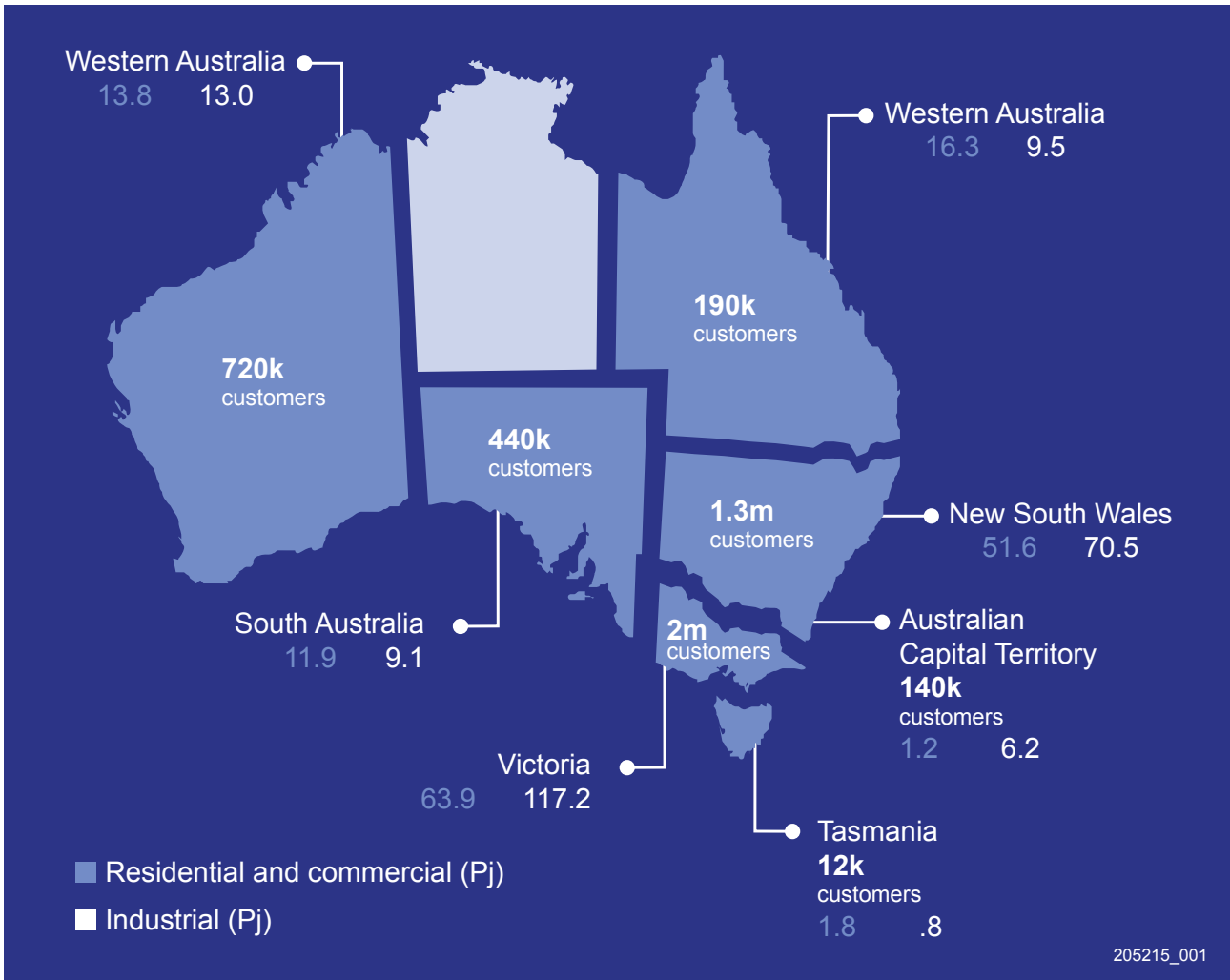

Figure 3 Distribution Network Connections & Consumption by State

Figure extracted (Deloitte Access Economics, 2017) figure 1

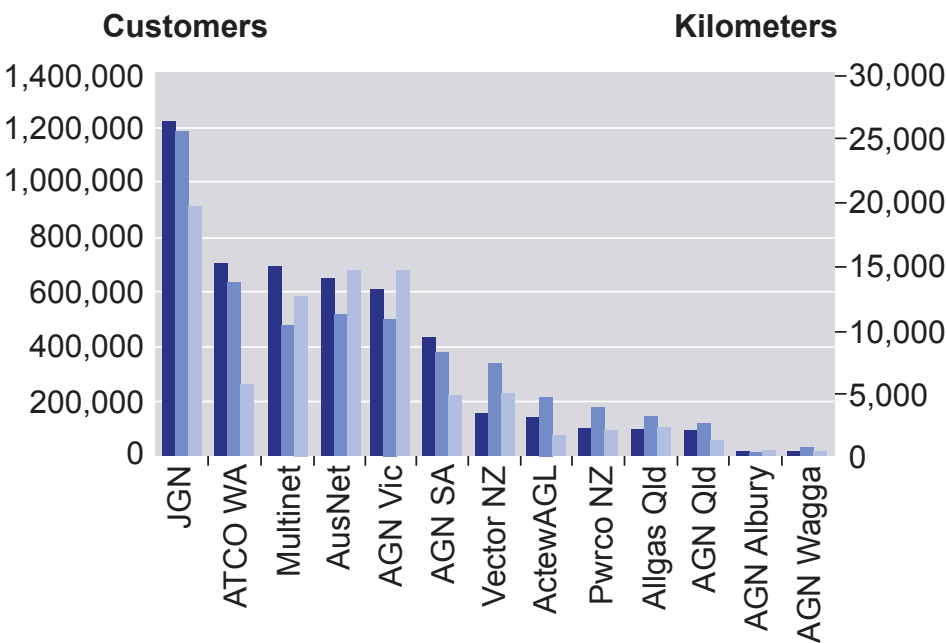

Figure 4 Customers, Energy Supplied and Length of Mains (Economic Insights Pty Ltd, 2014)

### 2.5.3 Network operating pressures

A distribution network consists of a range of operating pressures including:

- Transmission pressure comprised of the trunk main and primary main. This may supply large industrial users of natural gas.
- High and medium pressure mains provide a 'backbone' that services areas of high demand. They can transport gas between population concentrations within a distribution area or provide direct supply to major industrial or commercial consumers.

- Low pressure piping systems provide the final consumer mains connection for general commercial or domestic customers.

Table 3 provides operating pressures for piping systems used in Australian natural gas distribution networks. These pressures are averages; for some networks, the percentage of each pressure category vary. As the pressure decreases the pipeline materials transition from steel to plastics.

**Table 3** National gas distribution network operating pressures

Operating Pressures	National Average
Low Pressure ( $\leq 7$ kPag)	8.85%
Medium Pressure ( $> 7$ kPag but $\leq 210$ kPag)	45.28%
High Pressure ( $> 210$ kPag but $\leq 1,050$ kPag)	42.91%
Transmission Pressure ( $> 1,050$ kPag)	2.97%

(Energy Network Australia, 2019)

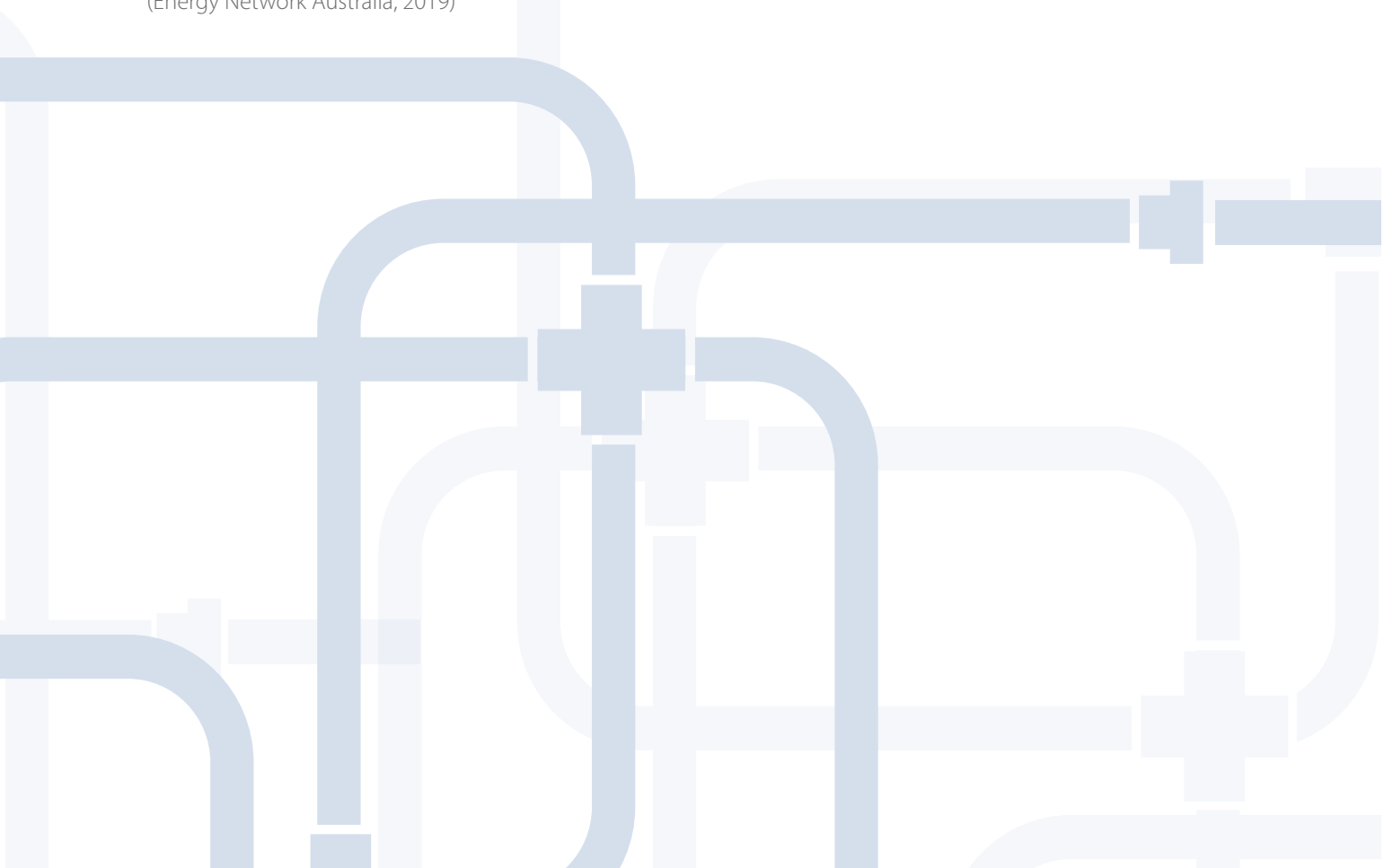
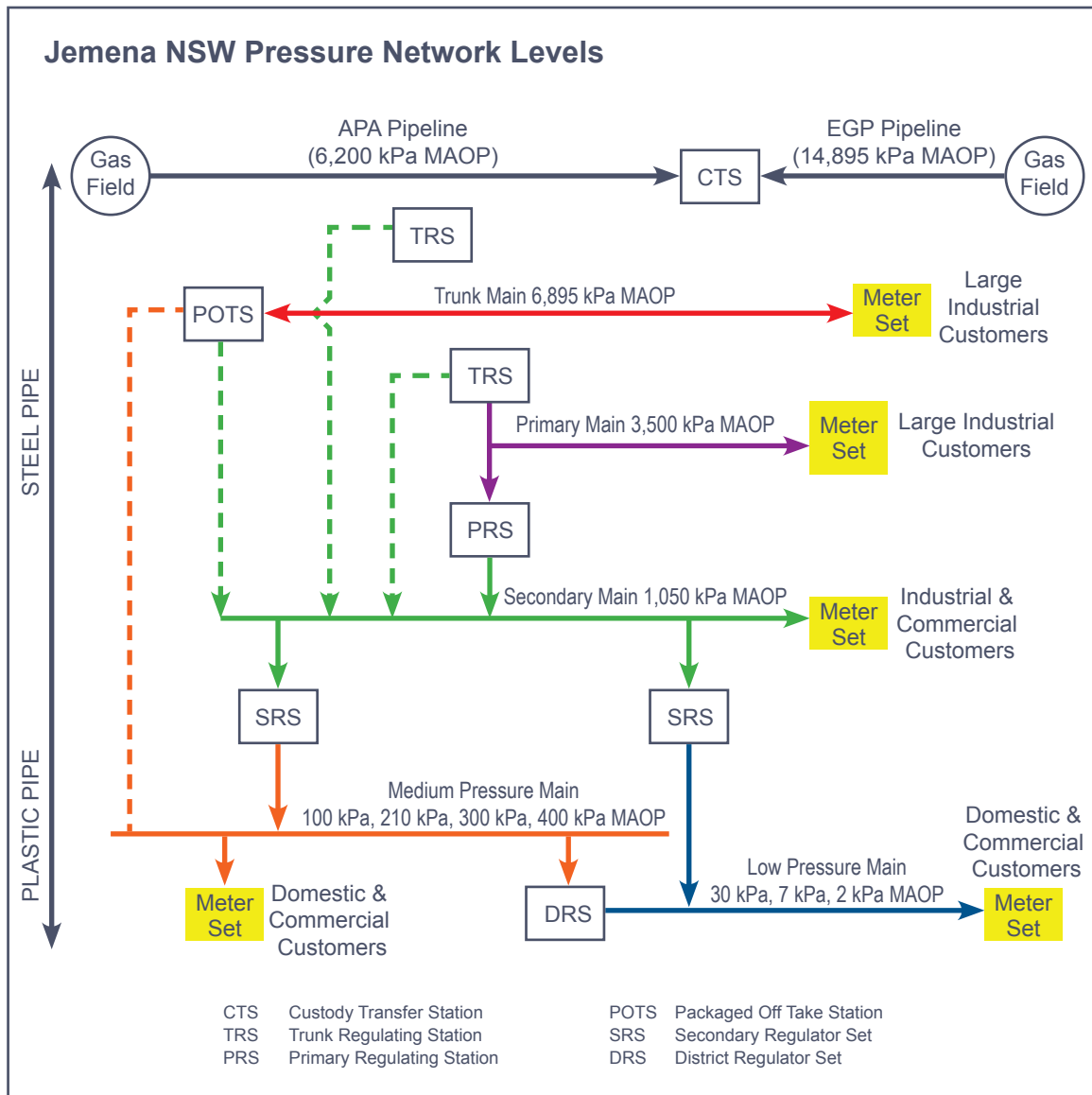

Figure 5 provides an example configuration of Jemena's NSW JGN network, where distribution mains at transmission pressure (>1,050 kPa<sub>g</sub>) are carbon steel piping systems. Plastic piping systems are used for medium and low pressure sections. The large industrial and commercial customers are supplied from the high pressure sections, the trunk main, the primary mains or secondary mains, with domestic customers supplied from the low and medium pressure mains. Each layer

of the distribution system is connected to the higher pressure source via a regulation facility, often from multiple supply points. The interconnected nature of the distribution system will require consideration for the location of gas quality measurement for monitoring of hydrogen percentage blends, particularly once multiple injection points are considered in the distribution system.



**Figure 5** Example Network Configuration  
(Jemena, 2018)

## 2.5.4 Network materials

Table 4 provides a breakdown of materials found in the Australian natural gas distribution networks, based on an internal (unpublished) report from Energy Networks Australia (ENA). The report identifies three main materials groups found in the natural gas distribution network: plastic (PVC, PE and Nylon); steel (protected and unprotected); and cast iron. This table gives the average national materials and for most networks the percentages could vary quite substantially.

**Table 4** National network materials

Material	National Average
Nylon	26.33%
Polyethylene	41.42%
PVC	10.92%
Cast Iron*	2.28%
Unprotected Steel	0.85%
Protected Steel	15.70%
Other	0.00%

\*Cast Iron is only found in low pressure applications (less than 1,050 kPa).  
(Energy Network Australia, 2019)

At the transition of the distribution network to the appliance, it is typical to find copper piping systems. In some cases, multilayer pipe consisting of a thin aluminium layer between two polyethylene layers is used; however, this material combination was not reviewed in this report.

### 2.5.4.1 Distribution mains replacement programs

The percentage of cast iron, PVC, older high density PE and some steel pipeline sections is will reduce in the future due to distribution networks undergoing “end of life” mains replacement programs. These programs include identifying old cast iron, PVC and PE and replacing it with modern PE.

Table 5 shows a large percentage of cast iron and unprotected steel mains existing across five of the Gas Distribution Businesses in 2012, totalling approximately 5.3%. This data shows a higher average than the more recent information from ENA, (3.1%), as shown in Table 4. The discrepancy is due to a number of mains replacement projects that have commenced in the intervening period.

Multinet in Victoria are undertaking replacement of their low pressure cast iron distribution mains (7 kPag operating pressure), some of which have been in service since the 1880's, with high pressure polyethylene. This replacement program has a target completion date of 2033.<sup>10</sup>

Australian Gas Networks have initiated their Mains Renewal Program (MRP) program across networks in Victoria, South Australia and Queensland which involves replacing the old cast iron pipes, unprotected steel and PVC mains with polyethylene pipes.<sup>11</sup>

It is important to understand the distribution of older pipeline sections that are potentially in degraded condition when considering the viability of hydrogen injection in the network. At the proposed injection location of hydrogen there may be a high percentage of incompatible materials, even though the network percentage is low. The entire network must be considered when selecting an appropriate injection location.

### 2.5.4.2 Recommendation for network materials

There is a large percentage of unknown material in natural gas distribution networks. These unknown materials may be adversely affected by the addition of even 10% hydrogen.

<sup>10</sup> (Multinet, 2019)

<sup>11</sup> (AGN, 2019)

**Table 5** Network Cast Iron / Unprotected Mains

Gas Distribution Business	Total Length (Km)	Customer Density (Cust/Km)	Cast Iron / Unprotected Mains %	City Gates (number)
AGN Vic	10,135	56.9	3.7	56
Multinet	10,147	66.0	13.2	6
AusNet	9,719	62.7	8.0	38
AGN SA	8,010	51.3	15.4	16
AGN QLD	2,643	33.7	8.5	11
AllGas QLD	3,022	28.9	15.7	7
Jemena JGN	25,076	45.5	0.6	74
Evoenergy	4,364	28.3	0.0	2
ATCO WA	13,035	49.2	0.2	15

Jemena’s JGN network was a relatively low percentage, even in 2012, as the former asset owner, AGL, commenced their replacement program in the 1990’s.  
(Jemena Gas Networks, 2019)

*The development of a detailed database of network materials and establishment of an assessment program is recommended. This recommendation is necessary to investigate the impacts of various hydrogen concentrations. This work is currently underway and is a medium term action because it is not prohibiting injection, but is required for upscale and higher utilisation of hydrogen in the distribution networks. It is expected that this recommendation will be driven by industry supported by research.*

There is currently related research being completed by various research organisations and industry groups and this work should be leveraged.

### **2.5.5 Composition**

Typical gas compositions were provided by operating companies across Australia to gain representative compositions for the various regions of the Australian distribution. The compositions were compared against regulatory limits to understand which parameters may become problematic in the future for injection of up to 10% hydrogen.

Appendix 2 includes the compositional data that was used to complete a gas properties calculation to assess the changes in overall gas properties introduced by a 10% hydrogen blend.

### **2.5.6 Town gas**

Until the 1970s town gas was used in the gas distribution networks rather than the currently used natural gas.<sup>12</sup> Town gas, also known as ‘syngas’ or ‘coal

<sup>12</sup> Transition to natural gas commenced in 1969 and was progressive over the following decades.



gas, used coal or oil as the feedstock to produce an impure gas that was comprised of carbon monoxide, methane, hydrogen, carbon dioxide and other constituents. The final composition used in the network was dependent on the feedstock used and the process used.

It was common to see hydrogen concentrations of 30% or above in the network, which, at that stage, included a high proportion of pipelines constructed of cast iron.

Singapore Gas Company (City Gas) is currently the sole producer and retailer of low-pressure pipe town gas in Singapore. The hydrogen content limit set-out in City Gas guidelines is currently between 41-65% hydrogen.<sup>13</sup> A high hydrogen content town gas has been operating in Singapore since 1861. The network is currently being converted from town gas to natural gas, and there is potential to use lessons learned from this process.

## 2.6 End-user

The following section reviews the impacts of up to 10% hydrogen blended with natural gas to end-users.

### 2.6.1 Downstream installations and appliances

While downstream impacts on consumer installations was not a primary focus of this study, a general understanding of the impacts of the addition of hydrogen to natural gas on consumer appliances is required to confirm the feasibility of hydrogen injection into distribution networks. The potential impacts of an increased hydrogen content in the gas supply to Type A appliances, Type B appliances, and consumers that use natural gas as a feedstock (rather than combustion), and the impacts on these processes is discussed below.

Hydrogen has a significantly higher flame speed, less energy on a volumetric basis, greater flammability and explosive ranges and burns at a higher temperature than natural gas. The addition of hydrogen can also impact the accuracy of metering, appliance materials integrity and the operation of appliance equipment.

---

<sup>13</sup> (City Gas, 2017)

As such the overall impact of the percentage of hydrogen proposed to be injected on the combustion characteristics of the resultant hydrogen-natural gas mixture need to be assessed

A burner adjusted at the manufacturer's rated heat input on pipeline natural gas (adjustment gas) will have flames that are free of:

- Yellow-tipping (incomplete combustion of the gas) – with the exception of decorative appliances;
- Light back into the burner ports (propagation of flames back through the burner); and
- Flame lifting<sup>14</sup> from the burner ports.

An increased hydrogen concentration has the potential to result in undesirable combustion characteristics such as light back (on ignition, shutdown, or from a stable condition), higher NO<sub>x</sub> emissions and the potential uncontrolled re-ignition of unburned gas remote from the burner injector.<sup>15</sup> The risk of each of these implications is dependent on appliance design.

#### 2.6.1.1 TYPE A APPLIANCES

Domestic and light commercial appliances are classified as Type A appliances.<sup>16</sup> These include cookers, space heaters, central heaters, water heaters, catering equipment and leisure appliances. Type A appliance design, operation and safety is covered under the AS/NZS 5263 – Gas appliances series of standards, AS 4563 – Commercial catering gas equipment, and AS 3645:2017 – Essential Safety Requirements for Gas Equipment.<sup>17</sup>

A large percentage of all domestic gas appliances (Type A) employ atmospheric burners. In an atmospheric gas burner the momentum of the gas jet exiting the burner

---

<sup>14</sup> Also known as "blow-off" or "lift-off"

<sup>15</sup> (Committee on Advanced Energy Storage Systems, 1979)

<sup>16</sup> (Committee on Advanced Energy Storage Systems, 1979)

<sup>17</sup> (Committee on Advanced Energy Storage Systems, 1979)

injector entrains, from the surrounding atmosphere, the primary air required for combustion.<sup>18</sup> The correct and stable operation of an atmospheric burner is based on the burner head design, burner mixing tube and burner venturi design which is premised on a specific gas delivery pressure, gas composition and associated combustion characteristics.

Currently, Australian natural gas appliances covered under AS 3645 are tested with a test gas as defined in section 3 of the AS/NZS 5263.0:2017 – Gas Appliance General Requirements.<sup>19</sup> The test gas of interest here is the Nb test gas of composition 13% hydrogen and 87% methane (mol%).<sup>20</sup> In general, most current natural gas appliances are tested with Nb gas which allows for excursions of up to 13% hydrogen in the gas quality. Although we are only dealing with 10% hydrogen content it is important to understand the testing regime employed in the AS/NZS 5263. The standard is designed to test for significant deviations in gas quality from what is defined as the reference gas composition.<sup>21</sup>

Under this study we are considering varying the reference gas composition to one which includes up to 10% hydrogen. For consistency with the criteria utilised in AS/NZS 5263, a nominal 10% hydrogen natural gas blend would potentially require testing with a new Nb gas of at least 21.7% hydrogen to allow for excursions in gas quality.

Internationally, European domestic gas appliances are routinely tested with a mixture of 23% hydrogen and 77% natural gas (known as G222 test gas) with no issues.<sup>22</sup> These findings suggest that in Europe, for atmospheric burners in appliances such as ovens, stove

tops, water heaters and space heaters, blends of up to 23% in natural gas can be accommodated by existing burners or existing burners with minor modifications. However, European test pressures are typically 2kPa whilst in Australia the burner pressure does not exceed 1 kPa, therefore a direct correlation with the effect on Australian appliances cannot be made (without further investigation).<sup>23</sup>

For blends of up to 10% hydrogen previous reports suggested that domestic appliances should not need design changes.<sup>24</sup> Phase 1 of the HyDeploy project recently completed in the United Kingdom (UK) has concluded that properly installed and maintained domestic appliances are just as safe whilst operating with a blended gas of up to 20 mol% hydrogen.<sup>25</sup> Additionally, work led by the Future Fuels Cooperative Research Centre (FFCRC) is currently underway to test Type A appliances to 10% hydrogen, and subsequently beyond 10% hydrogen to better establish the limit of their safe operation. This work is due for completion in the 4th quarter of 2019 and is directly applicable to determination of Type A appliance compatibility with 10% hydrogen for operation in the Australian context.

While a number of options for new burner technologies have been identified globally, there is currently no industry-wide consensus on the most feasible burners for use with high hydrogen concentration blends, and further research and development is will be required should future initiatives seek to explore hydrogen natural gas blends containing in excess of 10% hydrogen.

A specific review of domestic appliance regulations and standards, to identify any further regulatory or technical constraints, is recommended by this report.

---

18 (Committee on Advanced Energy Storage Systems, 1979)

19 (Standards Australia - AS 5263, 2013) Page 43

20 (Standards Australia - AS 5263, 2013) Page 44

21 There are two exceptions to this, commercial catering appliances and barbecues, for historic reasons they are not subjected to testing using Nb test gas.

22 (Messaoudani, 2016)

---

23 This is as a result of “town gas” with low pressure supply in cast iron mains. The appliances are currently leak tested to 14kPa but operated at 1 kPa.

24 (Messaoudani, 2016)

25 (Isaac, 2019)

### 2.6.1.2 TYPE B APPLIANCES

Commercial and industrial appliances that are not part of a certification scheme are classified as Type B appliances and include:<sup>26</sup>

- gas turbines,
- gas engines,
- kilns,
- industrial cookers, and
- boilers.

Type B appliance design, operation and safety is covered under AS 3814:2018 – Industrial and commercial gas-fired appliances.<sup>27</sup> These require special considerations before installation.

The installation of Type B is covered under AS/NZS 5601.1:2013 – Gas Installations - General Installations.<sup>28</sup>

Variations in quality of natural gas supplied to Type B appliances are also of concern to gas suppliers and equipment manufacturers. Similar to Type A appliances, Type B are designed to operate on a specific range of gas compositions and the range is dependent on the burner design. Combustion of gases outside this range can lead to a range of problems both technical and commercial.

The potential impacts of increasing hydrogen content in the fuel gas supply to commonly encountered Type B industrial appliances are discussed in subsequent sections.

#### 2.6.1.2.1 Gas engines

Natural gas engines supplied by the gas distribution network are used in a variety of applications and locations. Commonly these are found coupled with an electrical generator for power generation for constant or back-up power generation.

---

26 (Energy Safe Victoria, 2019)

27 (Standards Australia - AS 3814, 2018)

28 (Standards Australia - AS/NZS 5601.1, 2013)

Research suggests that gas engines are sensitive to changes in gas blends and fuel mixture concentrations.<sup>29</sup> An increase in hydrogen concentration will increase the flame speed and in turn cylinder peak pressures.<sup>30</sup> The methane number also decreases with the increase in hydrogen concentration which may lead to knocking or pre-ignition if the engine is not tuned to the fuel mixture correctly and potentially increased NOx emission.<sup>31</sup>

Introduction of hydrogen has also shown some benefits for engine performance such as improving the lean-burn capability and flame burning velocity of natural gas engines under lean-burn conditions as an increase in flow intensity is introduced in the cylinder which results in improved engine efficiency but at the expense of increased engine wear and increased NOx emissions.<sup>32</sup>

The general review of literature on the subject of hydrogen impact on industrial engines suggests broad acceptability only to concentrations up to about 2-5%.<sup>33</sup> However given the large and unknown variation in operating conditions of engines and their individual sensitivity to “knock” and NOx emissions based on gas composition, acceptability of hydrogen concentrations above approximately 2% should be investigated on a case by case basis.<sup>34</sup>

#### 2.6.1.2.2 Gas turbines

Gas turbines are highly sensitive to fuel quality and variability and slight changes in composition will affect the operating efficiency. Gas turbines can only tolerate limited changes in composition, depending on the burner design and the set-up of the controls. Any change in fuel composition requires tuning.

---

29 (EPCRC, 2017)

30 (Lee, 2002)

31 (Altfeld, 2018)

32 (EPCRC, 2017)

33 (EPCRC, 2017)

34 (EPCRC, 2017)

Before the regulation of emissions such as the oxides of nitrogen (NOX), gas turbines typically had diffusion flame combustors. These were very stable and tolerated wide ranges of fuel composition, but resulted in high NOX. Due to regulation, gas turbines installed since the mid-1990s are required to have lean premixed combustion system, often referred to as Dry Low NOX (DLN) or Dry Low Emissions (DLE) combustors<sup>35</sup>. These systems are significantly more sensitive to fuel variations because their operation has been optimised for a narrow range of conditions to minimise emissions.

Although an individual assessment is necessary, a gas turbine may only require minimal modifications to accept the new fuel blend, providing it is a homogenous and consistent blend. In some cases this may be as simple as a change in load in response to a problem such as high combustion dynamics or emissions. In the most complex cases, full model based control is used to effectively continuously optimise system behaviour, such as General Electric's OpFlex™ Balance Autotune® for the DLN 2.6+ combustion system.<sup>36</sup> In some systems, where the Wobbe Index (WI) is the critical parameter, controlled fuel heating can be used to modify the effective WI in response to fuel composition changes, as implemented in General Electric's (GE) Fuel Quality Management System.<sup>37</sup>

For gas turbines that are unable to operate on the new gas composition, modification or replacement of combustors will be required. In some cases combustion systems have identifiable design weaknesses and the manufacturer can improve combustion performance through modified burner and/or combustor design. This has been successful in increasing the flashback resistance of a number of burner types.<sup>38</sup>

Some manufacturers are currently researching the impact of hydrogen to gas turbines.<sup>39</sup> Modifications

---

35 (Abbott, 2012)

36 (Morrel, 2011)

37 (Forte, 2008)

38 (Abbott, 2012)

39 (Larfeldt, 2019)

to fuel injection systems have allowed the turbines to operate with hydrogen percentage up to 50% in some applications.<sup>40</sup>

As discussed in detail in section 5.2 a 10% hydrogen blend in the typical natural gas blends found in Australia generally stays within the specification limits set by AS 4564.<sup>41</sup> It is therefore expected that the turbines should be able to operate on a blend where characteristics vary between the limits set out in AS 4564 Table 3.1.<sup>42</sup> In operation however, while the turbines may operate at these conditions, there will be impact to the efficiency, reliability and durability of the units.

Generally, turbine manufacturers have a gas quality and composition specification that needs to be maintained in order to meet performance specifications. This is in addition to any gas network quality regulations. Contractually, if these quality requirements are not met the turbine may not be eligible to manufacturer warranty and is an area for further investigation.

The new natural gas / hydrogen blend of up to 10% hydrogen may only require minor modifications providing the new blend is homogenous and a consistent composition. Due to the wide variety of gas turbine models and applications, addition of 10% hydrogen to a gas turbine will require a case-by-case analysis.

Typically, gas turbines found at large gas power stations are found connected to the high pressure gas transmission network which falls outside of the scope of the report.

### **2.6.1.2.3 Industrial furnaces, heaters and boilers**

Furnaces, heaters and boilers are found in industrial applications. Many of the technical issues mentioned for domestic heating and hot water appliances also apply in the commercial and industrial sector.

---

40 (Noon, 2019)

41 Appendix 2 - Gas Composition Calculation

42 (Standards Australia - AS 4564, 2011) Page 9

These types of appliances are largely expected to function correctly with addition of up to 10% hydrogen, generally being able to tolerate a wider range of gas compositions than the engine and turbines discussed in previous sections. The major issue with these types of appliances generally relate to impurities rather than specific concentrations of hydrogen. The technologies to be incorporated into existing product lines to accommodate higher hydrogen concentrations already exist, although, as with domestic appliances, significant steps may be required to apply them to commercial appliances.

Industrial furnaces, heaters and boilers are designed to handle fuel changes by adjusting primary air to fuel ratio and although some minor adjustments may be required it is not anticipated that major issues will exist for hydrogen concentrations not exceeding 10%.

The replacement of natural gas with 10% hydrogen has the potential to increase the cost of heating for industrial users in some processes because more gas (volume) will be required to deliver the same amount of energy.<sup>43</sup>

Each industrial facility will need to complete assessments on their furnaces, process heaters and boilers to determine whether gas and primary air pressures can be adjusted to improve the flame stability and compensate for reduced flame radiation.<sup>44</sup> It is expected that most existing furnaces, process heaters and boilers can accommodate or be modified to enable a 10% hydrogen blend, however this would need further investigation.

#### **2.6.1.2.4 Compressed natural gas**

Compressed Natural Gas (CNG) is natural gas that is compressed from 1MPa to 20MPa. It is used as a cheaper and cleaner alternative to traditional hydrocarbon fuels such as petroleum and diesel. CNG is produced using mains supply of natural gas, and used in vehicle fleets across Australia.

---

43 (EPCRC, 2017)

44 (EPCRC, 2017)

Hydrogen in CNG is limited to approximately 2% (by volume) to avoid embrittlement in the high strength steels currently used in storage or transport of CNG.<sup>45</sup> There is also limits on the refuelling facility equipment e.g. compressor and the CNG engines themselves.

The impact of 10% hydrogen to the compressed natural gas systems, in particular the storage, should be further investigated and the delivery points in the network for supply to CNG processing facilities need to be considered when determining hydrogen injection locations in the network.

#### **2.6.1.3 Recommendations for downstream installations and appliances**

The review identified downstream appliances as a significant component of the distribution networks. Consequently, ensuring that they operate safely and reliably with the addition of any concentration of hydrogen is critical.

Review of the appliance standards and state regulations was excluded from the scope of this report but should be completed in an effort to identify barriers of hydrogen injection. This includes Type A (AS/NZS 5263 series and AS 4563) and Type B (AS 3814 and AS 1375) appliances as well as the gas installations standard (AS/NZS 5601).

Scoping will be required to identify the applicable state regulations concerned with the safety and technical aspects of downstream appliances and gas installations. It is recommended that this work be undertaken to further inform the regulatory reform required to allow for hydrogen in, and downstream of, the gas distribution networks.

---

45 (EPCRC, 2017)



*It is recommended that a technical and regulatory review of the impacts of addition of 10% hydrogen on downstream installations and appliances be undertaken. This recommendation is required to further review potential impacts identified in this report, and to ensure that there are no additional impacts to the operation, safety, efficiency and reliability of appliances beyond those already identified. This action should start immediately (noting that some aspects are already underway) as it will identify any further barriers to large scale injection. It is expected that this recommendation will be driven by industry and researchers with input from government.*

However, domestic and international projects that have reviewed impact to Type A appliances are very positive for up to 20% hydrogen with only minor knowledge gaps required to be filled. Further investigation is required for Type B appliances.

### **2.6.2 Feedstock for a production process**

Natural gas is used in industry as an industrial feedstock for a range of processes such as high temperature manufacturing and in chemicals, plastics and fertiliser production.<sup>46</sup> Changing the composition of the natural gas used in industry may have impacts on the efficiency of the process, require separation of hydrogen, or a modified process. Appendix 4 gives a summary of the processes that use natural gas as a feedstock.

---

46 (IT Power, 2015)

Initial consultation with industry regarding blends of 10% hydrogen in natural gas has revealed that a 10% hydrogen blend could improve the quality of some industrial chemical process such as the production of Ammonia. However, in many cases where natural gas is used as a feedstock in making chemicals there is no real alternative for hydrogen as a substitute.

Large industrial users of hydrogen currently source their hydrogen from a gas supplier or produce the hydrogen on-site from natural gas. In both cases, the production method is most commonly steam methane reforming of natural gas. The majority of these customers would generally be connected to high pressure transmission which may be beyond sections considered for hydrogen injection. For example the Orica Kooragang Island Ammonia Plant produces hydrogen using natural gas as a Feedstock.<sup>47</sup>

It is noted that introduction of a 10% hydrogen blend into the natural gas feedstock of a major hazard facility may be considered an operating modification to the major hazard facility depending on the facility inlet gas specification and license conditions requiring formal notification of the local regulator.<sup>48</sup>

Generally it is expected that existing industrial facility flow meters, instruments, valves, pressure vessels and compressors would not need to be modified, however each facility owner/operator would need to complete a full detailed site study. The detailed site study should document the changes required to re-balance the plant to the new gas specification.

Any changes required to re-balance plant need to consider the impact to manufactures warranties. Further to this;

- Facilities which include heat exchanges or a catalyst vessel in the natural gas process need to consider if they would require replacement to avoid high temperature hydrogen attack.
- Facilities which require high consistency (stability) of gas specification should review the options for gas blend control.

---

47 (Orica, 2019)

48 (Safe Work Australia, 2012) Page 5

- Facilities should consider metal embrittlement in all metal pipelines, vessels and other metal equipment including end use storage vessels.

Further consultation by the National Hydrogen Taskforce is required to understand the negative impacts to chemical processes and determine the tolerable hydrogen percentage for each type of process.

### 2.6.2.1 Recommendations for feedstock users

Some feedstock processes may be technically and commercially impacted by the addition of any concentration of hydrogen to the existing natural gas. Initial consultation with industry showed that for some processes the efficiency may increase e.g. ammonia production while for some it might decrease because hydrogen has less energy per volume than methane.

Generally it is expected that most industrial processes could tolerate a consistent 10% hydrogen blend with only minor modifications required to the process equipment.

However, each chemical process is bespoke due to the differing combinations of equipment makes, models, sizes and operating protocols, hence the tolerable hydrogen percentage for each industrial process needs to be assessed on a case by case basis.

*It is recommended that a scoping study followed by a technical, commercial and regulatory review of impacts of up to 10% hydrogen to feedstock users that use natural gas in a process be completed. This recommendation is required to confirm the technical and commercial impacts to feedstock users when hydrogen is added the natural gas.*

*This action should start immediately, in order to understand the impacts to these processes. It is expected that this recommendation will be driven by the National Hydrogen Strategy Gas networks work stream and research with input from government. A scoping exercise should be completed by COAG to better understand the users of natural gas as a feedstock in the natural gas distribution network. This would then be followed by detailed site reviews of the impacts (technical, commercial and regulatory) of 10% hydrogen in natural gas mixture on industrial processes.*

## 2.7 Retailer

Natural gas retailers buy gas in bulk from wholesale markets and sell it to residential and business customers. They serve as the main interfaced between domestic and industrial customers and the natural gas industry. Each gas retailer will supply gas at a cost which includes the cost of transporting natural gas through distribution networks. Gas retailers provide a range of services to consumers including:

- Facilitate the connection of a gas customer's premises to the gas network,
- Arrange for gas to be supplied to customer's homes or businesses,
- Bill customers for the gas that they use,
- Assist customers with any queries that they have about the sale of gas, and
- Provide information and assistance to customers with natural gas contracts.

## 2.8 Summary of existing gas network considerations

Table 6 provides a summary of the Australian gas network including; the distribution network, downstream users.

**Table 6** Summary gas networks and recommendations

Topic	Summary
Natural gas supply chain	The natural gas supply chain in Australia is a complex system that is comprised of the market, production, transmission networks, distribution networks, and energy retailers.
Gas Market	The natural gas supply chain is regulated by a national regulatory framework that comprises of the National Gas Law, National Gas Rules, National Energy Retail Law, National Energy Retail Rules and supporting Regulations.
Production	<p>Natural gas in Australia is supplied from conventional and non-conventional gas in hydrocarbon reserves which can be found both onshore and offshore.</p> <p>Currently, the gas production is regulated state-by-state.</p> <p>Recommendations for production facility regulation have been made as part of this report.</p>
Transmission Network	<p>Transmission pipelines transport natural gas from processing or storage facilities over long distances to domestic markets. The pipelines typically have large diameters and operate under high pressure to optimise shipping capacity.</p> <p>The transmission network is regulated by state government pipeline regulations and typically designed to AS 2885.</p> <p>The impact of 10% hydrogen on the natural gas transmission network is an area of future interest.</p>
Distribution Network	<p>The distribution network is a collection of pipelines transporting gas from the supply point of the transmission pipeline to an end-user. Gas distribution networks exist in each state and territory of Australia centred on capital cities, major regional centres and towns.</p> <p>A distribution network typically consists of high, medium and low pressure pipelines. Three main materials groups can be found in the natural gas distribution network; plastic (PVC, PE and Nylon); steel (protected and unprotected); and cast iron.</p>

Table 6 continued

Topic	Summary
End-user	<p>Review of downstream installation and appliance standards and regulations were excluded from the scope of this study, but a high level review of the impacts of addition of 10% hydrogen to natural gas distribution networks on appliances was completed for context. It was found that there are minor technical, commercial, safety and regulatory barriers to allowing injection of hydrogen into current gas installations and appliances. A more definitive conclusion would be subject to completion of the work currently underway by FFCRC.</p> <p>Processes that use natural gas as a feedstock were also considered. Initial consultation with industry regarding revealed that addition of 10% hydrogen could have a positive or negative impact on the process; this is dependent on the particular process.</p> <p>Recommendations for both downstream installations and appliances, and feedstock users have been made as part of this report.</p>
Retailer	<p>Natural gas retailers buy gas in bulk from wholesale markets and sell it to residential and business customers</p>

# 3 PROJECTS, PREVIOUS STUDIES and CURRENT RESEARCH

There are multiple projects underway domestically and internationally that are researching or practically testing the impacts of hydrogen injection into natural gas networks.

## 3.1 Australian injection pilot projects

In Australia there are currently four pilot projects trialling injection (or injection related activities) into the natural gas distribution networks. These projects are not designed to be economical but to develop greater understanding of hydrogen production and injection. Table 7 gives a summary of the injection projects that have been commenced in Australia.

**Table 7** Australian injection pilot projects

Project name	Location	Study objective	Facility completion date
Hydrogen Park SA (AGIG)	Tonsley Park (Adelaide), SA	Trial 1.25MW electrolyser for hydrogen production and inject a hydrogen blend, up to 5% by volume, into the existing Tonsley gas network. Potential to extend to tube trailer filling for bulk hydrogen transport.	2020
Western Sydney Green Gas Trial (Jemena)	Western Sydney, NSW	Select and trial a 500 kW Proton Exchange Membrane (PEM) electrolyser technology for hydrogen production and inject a hydrogen blend, up to 2% by volume, into the existing Sydney Secondary Mains. Trial of dispatchable power generation from a hydrogen microturbine. Potential to extend to on-site bus and vehicle refuelling.	2020
Hydrogen Test Facility (Evoenergy / Canberra Institute of Technology)	Canberra, ACT	To gain a clear understanding of the impact of introducing hydrogen to existing infrastructure. The project includes a 200kW PEM electrolyser and testing facilities.  Testing existing Australian network components, construction and maintenance practices on 100% hydrogen application.  Testing hydrogen as a broader energy storage source to support coupling the electricity network to the gas network.	2020



Table 7 continued

Project name	Location	Study objective	Facility completion date
		Appliance testing (e.g. testing hydrogen and mixed gases in existing appliances such as gas continuous hot water systems).  Testing production of hydrogen from intermittent solar energy in sufficient quantities for small scale domestic supply.	
Clean Energy Innovation Hub (ATCO)	Perth, WA	Trial the production, storage and use of renewable hydrogen, with an electrolyser powered by 300kW of on-site solar. The generated hydrogen is stored or injected into a micro-grid for testing as a direct fuel or blended with natural gas.	2019

### 3.2 International projects

Australia is typically not a first mover in technology and this is the case for hydrogen. Globally projects have been underway for some time and much of the required research and testing has been completed. A detailed list of hydrogen projects in Europe is outlined online.<sup>49</sup>

A remarkable increase in technology deployment in terms of ongoing projects dealing with renewable gas production processes started after 2010. Although the first pilot plant was erected in Japan, the current leadership holds in Europe, mainly thanks to the support of the governments of Germany, Denmark, Netherlands and Switzerland.

These experiences combine pilot and demonstration plants whose electrolyser sizes vary from few kWe (lab-scale plants) to 3x2.0 MWe (largest existing plant). The United States has also contributed to the deployment of the technology with up to four projects since 2009.<sup>50</sup>

#### 3.2.1 HyDeploy

Of particular relevance to this study is the HyDeploy study being undertaken in the UK. HyDeploy is a

pioneering hydrogen energy project to reduce UK carbon dioxide CO<sub>2</sub> emissions. Its aim is to investigate if blending up to 20% hydrogen with natural gas is feasible in reducing CO<sub>2</sub> emissions from home cooking and heating, without changing customer appliances.

As part of the HyDeploy, UK safety case exemption for the live pilot testing of a small private network of 100 homes for a 20% hydrogen natural gas blend has been approved and injection is scheduled for commencement in September 2019.<sup>51</sup> The approval for undertaking the live test was based on a submission that tabled evidence that the proposed hydrogen-natural gas blend was “as safe as” natural gas.

The submission included specific investigation and findings including the following:

1. Short term appliance behaviour;
2. Long term appliance behaviour;
3. Effect of hydrogen blend on materials;
4. Risks of poor mixing;
5. Fire and explosion risk;
6. Hydrogen detection; and
7. Customer perception.

49 (DNV GL, 2019)

50 (Bailera, 2017)

51 (Isaac, 2019)

This body of work is a useful reference for developing a frame work setting criteria for injecting hydrogen into an existing low pressure gas distribution network. In this body of work a quantitative risk assessment covering appliances, their installation and impact on detectability of leaking gas was completed comparing the risks associated with a hydrogen blended and unblended consumer gas installations.

### **3.2.2 H21 Leeds City Gate and H21 North of England**

The H21 Leeds City Gate project is a study aimed at determining the feasibility, from both a technical and economic viewpoint, of converting the existing natural gas network in Leeds, one of the largest UK cities, to 100% hydrogen.<sup>52</sup> The project was designed to minimise disruption for existing customers, and to deliver heat at the same cost as current natural gas to customers.

The project has shown that:

- The gas network has the correct capacity for such a conversion;
- It can be converted incrementally with minimal disruption to customers;
- Minimal new energy infrastructure will be required compared to alternatives; and
- The existing heat demand for Leeds can be met via steam methane reforming and salt cavern storage using technology in use around the world today.

The H21 Leeds City Gate project later became H21 North of England (H21 NoE), with a broader scope and the aim of transitioning the gas networks across the North of England to hydrogen. H21 NoE is a detailed engineering solution for converting gas distribution networks to 100% hydrogen between 2028 and 2034, with potential scope for further decarbonisation of the UK networks by 2050.<sup>53</sup>

---

52 (Sadler, 2016)

53 (Sadler & Solgaard Anderson, 2018)

## **3.3 Research and programs**

In addition to the physical pilot programs detailed in previous sections, there are a number of research programs underway domestically and globally.

### **3.3.1 Future Fuels Cooperative Research Centre (FFCRC)**

The Future Fuels CRC will develop solutions for gas networks to use hydrogen today and well into the future. Collaborating with over 60 companies, 6 universities, and several progressive regulators, the FFCRC is delivering three interdisciplinary research programs, as well as comprehensive education & training program involving 48 PhD students.

**Research Program 1** focuses on the understanding of the technical, commercial and market barriers to, and opportunities for, the use of hydrogen.

Techno-economic models of hydrogen production processes and supply chains are being developed to identify major technical or cost hurdles to the commercial uptake of hydrogen. Transformational technology will then be developed to solve these issues. Examples of such technology include novel separation technology for hydrogen-natural gas blends, as well as photocatalytic hydrogen production and methane pyrolysis.

On a broader scale network models are being developed that incorporate current plans for Australia's energy market and options for sector coupling with the electricity system; generating scenarios to meet its commitments at the lowest total cost to consumers.

Current research focuses on the properties of hydrogen-methane mixtures to determine how they will impact residential, commercial and industrial customers. A comprehensive appliance test program will be completed in 2019 to determine if standard household appliances can be accredited for operation on natural gas with 10% hydrogen blends.

**Research Program 2** studies the social and policy context, including public acceptance and safety, for technology and infrastructure associated with hydrogen.

Research in this program assists industry and government to understand and effectively address community-based issues and develop appropriate engagement solutions around hydrogen infrastructure projects. Ongoing research aims to understand public attitudes towards hydrogen and distil lessons learned from historic major upgrades to national infrastructure, including the transition from town gas to natural gas.

This program also produces outputs that will sustain the world's best practice safety and reliability performance of the Australian gas sector as it decarbonises. Therefore, FFCRC research focuses on regulatory best practice in other jurisdictions and adapts these to the Australian environment.

**Research Program 3** identifies and addresses gaps in relevant Australian industry codes and standards associated with design, construction and operation of gas networks.

The properties of hydrogen are different to natural gas. Blending hydrogen with natural gas, therefore, raises several materials, design and related safety issues that need to be addressed. For example, the long-term performance of network materials for the transportation of hydrogen are largely unknown. Therefore, experimental research is underway to provide knowledge on long term pipe and weld material performance with hydrogen. This research covers a wide range of steel and plastic grades used in Australian gas networks.

Research in this program also investigates release rates and dispersion characteristics of various hydrogen-methane blends after a rupture or venting operation. This allows for the development of appropriate safety zones around the new or repurposed high and low pressure gas networks. The outputs of this research feed directly into relevant industry codes of practice and design standards.<sup>54</sup>

FFCRC will run a 7 year research program and further research will be started in the years ahead to address industry needs.

---

54 (Future Fuels Cooperative Research Centre, 2019)

### **3.3.2 CSIRO – National Hydrogen Roadmap**

The National Hydrogen Roadmap developed by CSIRO has quantified the economic opportunities associated with hydrogen, including those for the gas distribution networks.

The primary objective of the roadmap is to provide a blueprint for the development of a hydrogen industry in Australia. With a number of activities already underway, it is designed to help inform the next series of investment amongst various stakeholder groups (e.g. industry, government and research) so that the industry can continue to scale in a coordinated manner.

The CSIRO is also undertaking a number of targeted R&D activities, including the development of new membrane technology to produce ultra-high purity hydrogen. This technology may lead the way for bulk hydrogen to be transported in the form of ammonia, using existing infrastructure, and then reconverted back to hydrogen at the point of use.

### **3.3.3 Australian Renewable Energy Agency (ARENA)**

With an aim to fast-track Australia's renewable hydrogen industry ARENA has awarded \$22.1 million in grant funding extended to 16 different and national research and development projects.

The funding, announced in September 2018, has been offered to research teams from nine Australian universities and organisations including the Australian National University (ANU), Macquarie and Monash Universities, Queensland University of Technology (QUT), Royal Melbourne Institute of Technology (RMIT), The University of Melbourne, University of New South Wales (UNSW), the University of WA, and the CSIRO. A full list of funding recipients and research topics can be found online.<sup>55</sup>

The funding, and the number of projects it will support, underscore the rapidly growing interest in renewable hydrogen, as a low-carbon fuel source, a potentially valuable export commodity, and as a form of energy storage.

---

55 (ARENA, 2018)

### 3.4 Summary of projects, studies and research

Table 8 provides a summary of the injection related projects that have been completed, the previous studies and the current research that is being completed; both domestically and internationally.

**Table 8** *Summary project and research*

Topic	Summary
Australian Injection Pilot Projects	In Australia there is currently four pilot projects trialling injection (or injection related activities) into the natural gas distribution network.
International Projects	Globally projects have been underway for some time and much of the required research and testing has been completed.
Research Programs	<p>A review of the research and projects that focus on injection of hydrogen into a distribution network was completed.</p> <p>Domestically research groups like FFCRC have identified gaps in knowledge and have started research projects which look at hydrogen as fuel.</p> <p>It is recommended, where possible, the learnings from pilot projects and research from organisations such as FFCRC be leveraged.</p>

# 4 IMPACTS and KEY CONSIDERATIONS

The following sections outline the impacts and key considerations identified by this study associated with blending 10% hydrogen into natural gas distribution networks.

## 4.1 Gas quality

Australia (except the Northern Territory) has adopted a uniform standard for natural gas that specifies limits for the major physical and chemical characteristics of natural gas providing a range for gas composition ensuring connected appliances operate safely. The key parameters specified include:

- minimum and maximum Wobbe Index (WI);
- maximum higher heating value (HHV),
- maximum inerts,
- maximum carbon dioxide (CO<sub>2</sub>),
- maximum nitrogen (N<sub>2</sub>),
- minimum and maximum specific gravity (SG), and
- minimum and maximum gas density.<sup>56</sup>

It should be noted that some of these parameters may not be mandatory; which is dependent on the state it is sold. In addition to the physical and chemical characteristics, the combustion parameters that are used to specify a particular gas composition are:

- Methane Number (MN),
- the Flame Speed Factor (S), and
- Sooting Index (I).<sup>57</sup>

As part of this project, gas compositions were obtained from various operator companies across Australia representative of the compositions in the various

---

56 (Standards Australia - AS 4564, 2011) Page 3

57 (EPCRC, 2017)

regions of the Australian distribution network. The reference compositional data was used to complete gas properties calculations assessing the impact to each representative gas sample's physical and combustion parameters as a result of blending with additional 10% hydrogen.

The following sections provide an overview as to the key characterising parameters of natural gas and the impact of introducing increasing concentrations of hydrogen.

### 4.1.1 Gas composition

Natural gas consists of hydrocarbons, inert gases and trace amounts of other compounds.<sup>58</sup> Methane is the predominant component of natural gas; heavier (longer chain) hydrocarbons such as ethane, propane, butane, pentane, and others appear in much smaller and diminishing amounts in natural gases.<sup>59</sup> Gas impurities include traces of compounds such as oxygen, hydrogen sulphide, hydrogen, water and radioactive gases and vary widely from state to state.<sup>60</sup> Table 9 provides a list of predominant natural gas components, their chemical symbols, and the typical mole % range produced in Australia.

It is important to remember that the composition of natural gas is not constant. Natural production variations mean that the percentage ranges of compounds in the natural gas fluctuate. The variations are not constant and influenced by a variety of factors. A good example is the seasonal gas composition

---

58 (EPCRC, 2017)

59 (Economic Regulations Authority: Western Australia, 2007)

60 (Economic Regulations Authority: Western Australia, 2007)



variation.<sup>61</sup> To allow for gas composition variations, calculations are completed using conservative categorisations of natural gas compositions defined as either a “lean” or “rich” gas.

A lean gas contains high levels of methane and fewer heavier hydrocarbons which reduces the heating value. A rich gas contains “heavier end” hydrocarbons which acts to increase the heating value.

The gas composition is used to calculate combustion and physical parameters which are used to define the technical and safety performance of a gas. It is also used for material selection to ensure suitability of materials.

Addition of 10% hydrogen to natural gas decreases the content of the hydrocarbons, inerts and trace compounds by a total of 10%. Appendix 2 provides compositions for typical natural gas blends found in each state as well as the compositions adjusted with 10% hydrogen.<sup>62</sup>

Previous studies have identified that adding hydrogen to natural gas will alter the gas composition which in turn impacts the following physical and combustion parameters: Higher Heating Value (HHV), Specific Gravity (SG), Wobbe Index (WI), Methane Number (MN), Flame Speed Factor, Sooting Index (SI), Flammability Limit, Minimum Ignition Energy, and the Joule-Thomson Coefficient. This section will review the impact of adding 10% hydrogen to each of these parameters.

61 (Hein, 2002)

62 Appendix 2 - Gas Composition Calculation

**Table 9** Typical natural gas composition

Name	Chemical Formula	Abbreviated Symbol	Range Mole%
Methane	C1H4	C1	70 to 98
Ethane	C2H6	C2	<15
Propane	C3H8	C3	<5
iso-Butane	C4H10	iC4	<1.5
n-Butane	C4H10	nC4	<1.5
iso-Pentane	C5H12	iC5	<0.5
n-Pentane	C5H12	nC5	<0.5
Hexane	C6H14	C6	<0.2
Heptane	C7H16	C7	<0.2
Octane	C8H18	C8	<0.1
Nitrogen	N2	N2	<10
Carbon Dioxide	CO2	CO2	<20

(Economic Regulations Authority: Western Australia, 2007)

#### 4.1.2 Higher heating value

The volumetric higher heating value (HHV) represents the energy content in a volume of gas when completely burnt in air at standard conditions.<sup>63</sup> AS 4564 defines HHV as the amount of energy (in MJ/Sm<sup>3</sup>) released when one cubic metre of dry gas, at standard conditions, is completely burnt in air with the products of combustion brought to standard conditions, and the water produced by combustion condensed to the liquid state.<sup>64</sup>

The volumetric HHV for a gas composition is the sum of the individual components weighted percentage of the components heating values. Methane has a volumetric HHV of 37.7MJ/Sm<sup>3</sup> while hydrogen is 12.1 MJ/Sm<sup>3</sup> at standard conditions.<sup>65</sup> Table 10 gives the volumetric HHV of a 10% hydrogen / 90% methane blend.

63 (EPCRC, 2017)

64 (Standards Australia - AS 4564, 2011) Section 1.6.2

65 (EPCRC, 2017)

**Table 10** Volumetric HHV for 10% hydrogen / 90% methane blend

	Volumetric HHV (MJ/Sm <sup>3</sup> )
methane	37.7
hydrogen	12.1
10% hydrogen / 90% methane	35.1

Adapted from (EPCRC, 2017)

HHV is a function of the composition and because production composition varies, the limiting HHV's for a rich gas and lean gas are quoted. Due to the reasons described in section 4.1.1 a lean natural gas has a lower HHV than a rich natural gas. For a 10% hydrogen / 90% methane blend, the HHV will decrease by 6.8%.<sup>66</sup> For a typical natural gas composition found in Australia the calculated decrease of HHV would be approximately in a range of 6-8%.<sup>67</sup>

The likely technical consequence of natural gas with hydrogen used as a fuel in reciprocating engines or gas turbines, without tuning, is a loss of efficiency.<sup>68</sup> The lower HHV and the lower density of the gas also affect the efficiency of gas appliances such as burners and cookers.

Higher heating value is a key to commercial action of the cost of natural gas as it refers to the energy value of the gas.<sup>69</sup> The higher heating value is used as one of the parameters to calculate the cost of gas. To achieve the same energy throughput for a lower HHV gas composition an increase in flow quantity would be required. Higher volumes of gas may require addition or modification to existing infrastructure such as supply regulators, metering and increased pipe diameter.

66 (Marianae, 2012)

67 Appendix 2 - Gas Composition Calculation

68 (Dodge, 1994).

69 Adapted from (EPCRC, 2017)

### 4.1.3 Specific Gravity

Specific gravity (SG), otherwise known as relative density, is the ratio of the density of a gas mixture compared with air density at standard conditions and is an important parameter in gas flow measurement and gas transactions.<sup>70</sup>

At ambient conditions, pure hydrogen is a diatomic gas with a low density of 0.083 kg/Nm<sup>3</sup> (approximately 11% of that for natural gas) compared to 1.25 kg/Nm<sup>3</sup> for air. It is the lightest element and in air, its buoyancy causes it to rise and disperse rapidly (at approximately 20 m/s).<sup>71</sup>

The low density of hydrogen added to natural gas causes the mass per unit volume to decrease, lowering the specific gravity of the mixture.<sup>72</sup>

The specific gravity of 10% hydrogen in natural gas decreases approximately 10% over that of unblended natural gas.<sup>73</sup>

A decrease in SG will tend to increase the flow of gas and resultant gas velocity and pressure losses through the equipment for the same mass flow. The SG is also used in the calculation of the Wobbe Index which is further discussed in this report.

### 4.1.4 Wobbe Index

The Wobbe Index (WI), sometimes called the exchangeability factor,<sup>74</sup> is a physical parameter of gas quality.<sup>75</sup> It is expressed in MJ/Sm<sup>3</sup> and is calculated when the higher heating value of the gas is divided by the square root of the relative density of that same gas. The WI accounts for the flow and heat inputs of the gas through an orifice at constant pressure. It represents an amount of energy that can be delivered through an

70 (Marshall, 1941)

71 (Kiwa, 2016)

72 (Kuczynski, 2018)

73 Appendix 2 - Gas Composition Calculation

74 "Gas exchangeability" is defined in the definitions and abbreviations section of this report.

75 (SAE International, 1986)

appliance and is a good indicator of gas combustion, although it is recognised by the gas industry that the WI, on its own, is not a sufficient determining factor of gas exchangeability. This is because it does not fully predict or define combustion behaviour.<sup>76</sup>

The high and low gas quality limits define the values beyond which the WI is not permitted to vary. Within these limits appliances have been designed and tested to operate safely.<sup>77</sup> For gases that are outside the defined limits there may be technical, safety, regulatory and commercial impacts.

Addition of 10% hydrogen to a typical natural gas blend decreases the WI approximately 2%, although this is dependent on the original natural gas composition.<sup>78</sup> While this seems relatively insignificant it has implications for a lean natural gas that is near the lower limit of the WI.

As WI is significant for burner interchangeability, a non-compliance with minimum WI requirements should be treated as a significant technical impact. The likely consequences of falling below the lower limit are flame lifting, flame blowouts, release of unburned hydrocarbons and, in some cases, increased carbon monoxide generation.<sup>79</sup>

In addition, a WI that is outside the limits may need commercial consideration. WI is used as the basis for calculating the value of gas in commercial contracts. A WI that is outside the limits set in the contract could lead to the incorrect valuation of gas.

#### **4.1.5 Methane Number**

The Methane Number (MN) is generally referenced with respect to fuel supply to internal combustion engines to describe the “knock” characteristics of the fuel.<sup>80</sup> The ultimate impact on the performance of an engine

depends on the specific gas composition of the fuel and in particular the amounts of higher hydrocarbons (C3, C4, and C5) and hydrogen in the fuel gas.

The methane number for a blend of 90% methane and 10% hydrogen is 90.<sup>81</sup> The methane number reduces for a richer blend of natural gas due to the presence of heavier hydrocarbons.

Technically, a methane number that is not within the manufacturer’s recommended limits could result in engine knock.<sup>82</sup> Knock is detrimental for the performance and reliability of gas engines.<sup>83</sup>

#### **4.1.6 Flame speed factor**

The flame speed factor is a calculated combustion parameter related to flash back and flame stability. The parameter is important in appliances for pilot orifice sizing, flame length and flame turndown.<sup>84</sup>

Flame speed also has a significant impact on the magnitude of the compressive wave developed when the gas ignites particularly in enclosed areas.

For pure hydrogen flame the speed of the flame means that during a depressurisation event (such as a blow down) when the pressure in the system drops the flame could burn back into the vent.

Previous research suggests that for a 10% hydrogen blend in natural gas, the flame speed may increase by approximately 10%.<sup>85</sup> This may have an impact on flame stability in connected appliances as detailed in previous sections.

#### **4.1.7 Sooting Index**

The sooting index describes the potential for incomplete combustion of the gas mixture and

---

76 (Haeseldonckx, 2007)

77 (Standards Australia - AS 4564, 2011)

78 Appendix 2 – Gas Composition Calculation

79 (EPCRC, 2017)

80 (Malenshek, 2009)

---

81 (Altfeld, 2018)

82 (Ryan, 2008)

83 (Sivabalakrishman, 2013)

84 (Committee on Advanced Energy Storage Systems, 1979)

85 (Altfeld, 2018)

the propensity to form carbon monoxide or solid depositions following combustion in burners.<sup>86</sup>

It is referred to as a calculated parameter for compliance and is only a requirement in the Gas Regulations 2012 South Australia. The 2011 revision of *AS 4564:2011 – Specification for General Purpose Natural Gas* considered sooting indexing but it was not deemed necessary for inclusion.<sup>87</sup>

Depending on the gas composition the sooting index will decrease by approximately 3-5% for 10% hydrogen in the natural gas.<sup>88</sup>

The addition of 10% hydrogen in natural gas improves the completeness of combustion and lowers the sooting index.

#### **4.1.8 Flammability limit**

The lower flammability limit (LFL) and upper flammability limit (UFL), also commonly referred to as lower explosive limit (LEL) and upper explosive limit (UEL), describe the concentration of a gas mixture in air within which an explosive gas atmosphere will be formed.<sup>89</sup>

The LFL and UFL of pure methane is 4.4% and 17.0% while the LFL and UFL of pure hydrogen is 4.0 % and 77.0% respectively.<sup>90</sup>

The LFL and UFL of 10% hydrogen with methane can be estimated using Le Chatelier's mixing rule as 4.36% and 18.44% respectively. Increasing the blending percentage of hydrogen in natural gas will result in an expanded flammability range over that of natural gas.

The most significant impact of a differing LFL and UFL is with respect to the classification of hazardous

flammable gas atmospheres as defined in AS/NZS 60079.10.<sup>91</sup>

The implication of an expanded flammability range of a gas mixture is an expanded extent of hazardous area zone – that is the increase in size of the zone in which a potentially explosive atmosphere may be formed.<sup>92</sup> The extent of hazardous area zones is typically calculated based on a fraction of gas mixture LFL (commonly 50% or less if the gas composition is considered more variable). The extent of hazardous area zones calculated using 10% hydrogen with natural gas will be larger than that calculated using pure natural gas due to the lower LFL.

The effect of the lower LFL, however, is minimal (less than 5% difference for a 10% blend), and within typical conservatism used in hazardous area extent calculations (50%).

The impact and applicability of hazardous area standards compliance is further discussed in section 4.4.1.

#### **4.1.9 Flame emissivity**

A pure hydrogen flame has different burn characteristics than that of natural gas.<sup>93</sup> Light emitted from burning pure hydrogen is in the ultraviolet range and is not visible to the human eye.<sup>94</sup> However it does burn with a coloured flame in the presence of combustion process contaminants and certain metal and non-metal components e.g. iron and sodium.

A typical natural gas flame is a blue in colour, with a luminous yellow region at the flame tip. A gradual spreading for the yellow colour flame, triumphed over the blue colour, is observed with the increase of the hydrogen concentration.<sup>95</sup> Once the hydrogen fraction reaches 40%, the entire flame becomes yellow except the near burner region still blue in colour.<sup>96</sup>

---

86 (South Australian Government, 2017)

87 (Standards Australia - AS 4564, 2011) Section A3.9

88 Appendix 2 – Gas Properties Calculation

89 (Standards Australia - AS/NZS 60079.10.1, 2009) Section 3.17 and 3.18

90 (Standards Australia - AS/NZS 60079.10.1, 2009) Annex B

---

91 (Standards Australia - AS/NZS 60079.10.1, 2009)

92 (Standards Australia - AS/NZS 60079.10.1, 2009)

93 (EPCRC, 2017)

94 (Altfeld, 2018)

95 (Schefer, 2009)

96 (El-Ghafour, 2010)

For 10% hydrogen blends in natural gas the flame emissivity is considered similar to that of 100% natural gas. There is no identified increased risk associated with 10% hydrogen with regards to the flame colour.

Where flame detection devices are required natural gas and hydrogen flame detectors are readily available but existing installations are considered unlikely to be impacted if the hydrogen concentration is limited to 10%.

#### 4.1.10 Joule-Thomson coefficient

The Joule-Thomson (JT) effect is defined as the differential change in temperature of a fluid with pressure at constant enthalpy and composition when it is forced through a valve or porous plug.<sup>97</sup> The Joule-Thomson coefficient can be expressed in terms of the gas's volume, its heat capacity at constant pressure and its coefficient of thermal expansion.<sup>98</sup>

Hydrogen has a negative Joule-Thomson coefficient and is one of only three naturally occurring gases which have this characteristic.<sup>99</sup> For pure hydrogen, any reduction of pressure in a system would see an increase in temperature of the gas downstream of the pressure reduction equipment. Unlike hydrogen, the natural gas JT coefficient is positive and cooling of the gas under the same conditions is observed.<sup>100</sup>

A blend of natural gas with hydrogen will see a change in gas temperature dependent on the blend proportion, the reduction pressure, temperature and composition of the gas. Appendix 3 gives typical gas distribution pressure reductions and shows that for 10% hydrogen / 90% methane blends the temperature in a typical pressure cut scenario increases.

At the operating pressures in natural gas distribution networks the negative JT cooling coefficient is not considered a risk. Consideration will be required for

97 (Smith, 1970)

98 (Perry, 1984)

99 (Hendricks, 1972)

100 (Hossian, 2017)

high pressure networks e.g. transmission networks which are outside the scope of this report but in general the impact on JT effect will not be detrimental for hydrogen concentrations up to 10%.

#### 4.1.11 Minimum ignition energy

Minimum Ignition Energy (MIE) is the energy that is required to bring a gas to a temperature that will allow combustion.<sup>101</sup> For a flammable gas (within its flammability limits) to be ignited the most important criteria which must be met is the requirement of the minimum energy to start and sustain the combustion of the gas. For a given gas, if the composition of the gas-air mixture is varied, the curve of the limiting energy necessary for ignition exhibits a distinct minimum. This minimum value is designated the Minimum Ignition Energy (MIE).

MIEs for most of the flammable hydrocarbon gases are very small (0.30 mJ and less).<sup>102</sup> The MIE of hydrogen is different than the minimum ignition temperature of methane, and the MIE of a H<sub>2</sub> / CH<sub>4</sub> mixture varies based on the quantity of hydrogen in the gas mixture.<sup>103</sup> Table 11 gives the theoretical minimum ignition energy for pure gases.

Table 11 Minimum Ignition Energy of pure gases

Gas Composition	Minimum Ignition Energy (mJ)
methane (100% CH <sub>4</sub> )	0.29
hydrogen (100% H <sub>2</sub> )	0.019

(Mathurkar, 2009)

It is reported that the MIE decreases proportionally with the increase of the hydrogen fraction.<sup>104</sup> For a 10% hydrogen blend it is expected that the MIE will be similar to that of a pure methane blend although the actual value has not been determined.

101 (Mathurkar, 2009)

102 (Mathurkar, 2009)

103 (Messaoudani, 2016)

104 (Hankinson, 2009)

### 4.1.12 Auto ignition temperature

The auto-ignition temperature is the minimum temperature of a hot surface that can ignite a flammable mixture.

The auto-ignition temperatures of methane and hydrogen are very similar. When compared in standard tests these are 600°C and 560°C respectively.<sup>105</sup>

For 10% hydrogen in a natural gas the auto-ignition temperature is not expected to be significantly different from that of a 100% natural gas composition.

Additionally, pure hydrogen is susceptible to spontaneous ignition when released into the air at relatively low pressures.<sup>106</sup> For lower concentrations of hydrogen in natural gas the risk of spontaneous ignition is not considered a risk.<sup>107</sup>

### 4.1.13 Moisture vapour

In general maximum moisture content is specified such that free water is never present within a gas pipeline. Water content is limited due to the fact that when combined with oxygen, carbon dioxide or hydrogen sulphide, internal corrosion can occur within the pipeline system. Levels of all four impurities, including moisture content, are strictly controlled in natural gas pipelines.

The amount of moisture vapour produced during the production of hydrogen is dependent on the process selected. Typically purification is used post production to remove oxygen and moisture from the hydrogen.

Addition of up to 10% hydrogen is unlikely to impact moisture vapour if adequately treated in the distribution network.

However, the addition of hydrogen to a natural gas blend will increase the water produced during combustion. This does not directly impact the distribution network but should be considered when reviewing the downstream appliances for suitability.

---

105 (Health and Safety Laboratory, 2015)

106 (Astbury, 2008)

107 (Health and Safety Laboratory, 2015)

## 4.2 Network injection, capacity and blending

Impacts of blending hydrogen into the gas pipeline networks include reduction in network storage and flowing capacity due to lower heating values and gas blend densities, possible gas quality variations into the network, and non-uniformity of higher heating value within the network. These impacts are discussed further below.

### 4.2.1 Network capacity

Although a gas network is used to transport a physical gas, commercial contracts and billing are calculated in energy content, rather than by volume or mass.

To achieve the same rate of energy delivery the volumetric flow rate must be increased for a hydrogen blended gas composition due to its relative lower heating value.<sup>108</sup> This is due to the lower volumetric and energy density of hydrogen in the vapour phase. The fluid velocity will increase with an increase in volumetric flowrate resulting in an increase in pressure loss.

The Wobbe Index can also be used in determining the impact of the gas quality variation on the capacity of a pipeline to transport energy.<sup>109</sup>

Based on the variance in Wobbe Index the magnitude of the capacity loss with a 10% hydrogen blend is on average estimated as approximately 2.4%.<sup>110</sup>

For pipelines where delivery rates are already contracted or tightly constrained, pipeline capacity should be assessed. Network operators will need to assess their gas distribution systems for potential physical bottlenecks that limit flow-rate, given that hydrogen addition increases volumetric flow-rates and pressure drop for the same energy delivery rate; which could result in increased haulage costs. There may be changes required, the full extent

---

108 (EPCRC, 2017)

109 (Economic Regulations Authority: Western Australia, 2007)

110 Appendix 2 – Gas Composition Calculation



of which and associated costs will require further detailed investigation of the specific network under consideration.

#### **4.2.2 Injection location, mixing and production variability**

The locations, flow-rates and variability in hydrogen injection rates will influence the composition of blended gas throughout distribution networks.

The management and limiting of the variability of the resultant gas composition provided to consumers is a key element in progressing with hydrogen injection into the network.

This issue could be managed through a combination of the following measures:

- The selection of the number and location of distributed injection points relative to specific consumers;
- The co-location of hydrogen generation facilities with locations that provide access to renewable alternative power sources that allow more continuous power availability such as co-located solar and wind by direct connection or through the negotiation of supply contracts which allow the lower cost power to be made available via the national grid; and
- Storage of produced hydrogen and controlled injection to maintain desired hydrogen – natural gas ratios.

The above becomes of particular importance as the hydrogen percentage increases to avoid excessive variability in the gas composition supplied to consumers.

Impacts are likely to be minimal with blending rates up to 10%, unless sensitive equipment e.g. gas engines and turbine, but injection points will require planning and modelling on a case-by-case basis. Modelling should take into account the variability of the gas demand at specific locations in the network as well as the variability of the production profile.

Continuous monitoring of gas composition will be required at strategic locations within the network to ensure concentration limits are not exceeded and appropriate control of injection flow provided. This will most likely require additional Process Gas Chromatograph's (PGC) to be installed throughout the distribution network.

Guidelines should be established to assist network operators in managing their networks so that gas with hydrogen exceeding 10% is not delivered to end consumers. Learnings from demonstrations plants both domestically and globally should be used to form the basis of the guidelines.

##### **4.2.2.1 Recommendations for injection and blending**

The locations, flow-rates and variability in flow-rate of hydrogen injection will influence the composition of blended gas throughout distribution networks.

Impacts are likely to be minimal with blending rates up to 10%, however it will require planning and modelling on a case by case basis. Establishment of guidelines to assist network operators to manage their networks so that gas with hydrogen exceeding 10% is not delivered to appliances will be required.

Learnings from demonstrations plants both domestically and globally should be used to form the basis of the guidelines.

*It is recommended that a blueprint for injection and blending be developed to ensure gas quality across the network. Development of guidance on industry best practice would streamline the injection process and assist network operators to manage their networks so that 10% hydrogen is not exceeded at appliances. This is a medium term action as currently*

*injection is assessed on a case-by-case basis. It is expected that this recommendation will be driven by industry and research, with support from government.*

### **4.2.3 Gas mixture stratification in pipelines**

Stratification describes the situation where fluids of different densities form different vertical layers. In gases, stratification can occur initially, when two gases are first mixed and the bulk properties of one cause it to rise or fall relative to the other (such as plumes from vents or chimneys). However, over time gases diffuse due to random particle motion, forming a substantially homogeneous mixture.<sup>111</sup> This process is accelerated by mixing which will occur rapidly where there is any turbulent flow.

Turbulence is always present on the pipe inner surface, and it will not require a long distance of piping downstream of injection points for the hydrogen-natural gas mixture to have become homogeneous. Where low flow conditions generate a concern of poor mixing, injection methods that maximise mixing can be used, such as by using injection quills which increase the velocity of the incoming flow, or multiple quills, so that the hydrogen is dispersed in the gas flow. It is not expected that this would be required in real conditions because the gas user is generally a significant distance downstream of the injection point.

Based on the above it is concluded that stratification in piping downstream of hydrogen injection does not require consideration. However, PGC's and testing in pilot programs will further enhance confidence that no stratification is present in a system.

---

<sup>111</sup> Theoretically, the equilibrium condition for a gas will exhibit a concentration gradient in which lighter particles are found at higher concentrations at the top of the space than at the bottom. However, this effect is negligible at small scales.

### **4.2.4 Measurement and metering of gas**

Accurate measurement of composition and flow-rate are required for gas pricing and commercial transaction. This is relevant for custody transfers between gas shippers or industrial customers, as well as for billing of smaller gas users such as households and businesses.

Gas chromatographs are used throughout the gas networks to measure the gas composition at various locations. For lower percentages of hydrogen in the mixture these measurements devices can be calibrated, for up to 5% hydrogen depending on the model. For levels greater than 5% hydrogen the device may need to be replaced by a model capable of handling higher volumes of hydrogen.<sup>112</sup>

In plants and gas distribution systems, heating value and composition can both be determined by process gas chromatographs (PGCs). The current generation of process gas chromatographs which use helium as the carrier gas are unable to detect hydrogen because of the relative proximity of their thermal conductivities (helium = 151 W/m<sup>2</sup>K; hydrogen = 180 W/m<sup>2</sup>K).<sup>113</sup> PGCs which use helium as a carrier gas are not able to measure hydrogen and will need to be modified or replaced by new models which use Argon or another carrier gas, thereby incurring additional costs. Some manufacturers have already produced PGCs capable of measuring natural gas containing up to 10% hydrogen.

Calculation of mass flow from volumetric meters, e.g. turbine meters, relies on measured pressure and temperature, but typically use an assumed value for gas molecular weight. For such meters, accuracy becomes less certain with increasing hydrogen concentration, especially at concentrations above 10% hydrogen. As a consequence, there is scope for measurement errors if the amount of hydrogen in natural gas is variable. However, calibrations can be made if the new gas composition is known and doesn't vary significantly. Variability in composition will require adoption of mass flow meters or use of updated PGCs to measure

---

<sup>112</sup> (EPCRC, 2017)

<sup>113</sup> (Altfeld, 2018)

composition and perform on-line flow-meter calibration.

Confirming suitability of gas chromatographs for hydrogen service needs to be assessed on a case-by-case basis. The Original Equipment Manufacturer (OEM) should be consulted to ensure that calculation of specific gravity, isentropic coefficient, compressibility, heating value, Wobbe Index and other equations of state parameters remain accurate.

Measurement of gas flows and monitoring of resultant compositions will also be a requirement for effective control of gas injection rates as described in the previous section.

#### **4.2.4.1 Recommendation for gas metering and measurement**

Improper operation of gas quality measurement devices resulting in inaccurate gas quality's or gas flow measurements.

Review of gas measurement equipment used in the network and confirmation of suitability manufacture. This may include specific method of gas calibration or materials requirements.

*It is recommended that a review of the technical and commercial suitability and integrity of gas measurement and metering devices installed in the distribution network be completed for addition of up to 10% hydrogen. This recommendation is required to ensure that gas measurement equipment used for flow regulation and billing is accurate and safe for hydrogen concentrations of up to 10%. This is a medium term action as pilot facilities are currently assessing on a case-by-*

*case basis, however a broader review would be beneficial for increasing hydrogen utilisation in the distribution networks. It is expected that this recommendation will be driven by industry (both network operators and equipment manufacturers) with support from research.*

Initial review will require equipment model details from the network operators. The equipment manufacturers will then be able to assess suitability and provide recommendations. For concentrations of up to 10% hydrogen it is likely that the equipment can be calibrated or upgraded.

### **4.3 Network construction materials**

The following sections consider the materials issues presented by injecting concentrations of up to 10% hydrogen into the distribution networks and the impact on both leakage and pipeline integrity.

#### **4.3.1 Plastic piping**

The natural gas distribution networks in Australia utilise a variety of plastic piping materials including; Nylon, PE63 (High Density), PE80 (Medium Density), PE100 (High Density), and Polyvinyl Chloride (PVC).<sup>114</sup>

It is possible that in parts of the network there are further types of plastic piping installed but these materials have not been considered as part of this review. This review of the plastic piping compatibility is completed for new (or near new) piping systems.

It is important to consider that plastic piping systems have been used in Australian gas distribution networks for over 40 years. The PE composition found in the networks may be different from modern PE pipe, with the condition of some piping being poor.

---

114 (Energy Network Australia, 2019)

#### 4.3.1.1 Degradation

Polymer degradation is a change in the properties of the polymer – such as tensile strength, colour, shape, molecular weight – or of a polymer-based product under the influence of one or more environmental factors, such as heat, light, chemicals, or any other applied force.<sup>115</sup> Polymer degradation can occur via UV radiation, heat or chemical reaction.<sup>116</sup>

A study of 20% hydrogen in natural gas (primarily consisting of methane) of both PE100 (PE) and PA11 (Nylon) over 3 years at 100 bar showed no significant changes in mechanical properties.<sup>117</sup> Further testing completed on polymer pipes indicated that pure hydrogen will not increase the degradation of polymer pipe materials.<sup>118</sup>

For 10% hydrogen in natural gas distribution networks, degradation is not considered an issue for new plastic piping systems.

For aged plastic piping addition of 10% is not expected to be an issue but further work is required to confirm this. Reviews and testing of aged plastic piping systems are currently being completed, domestically and internationally, and should be leveraged.

#### 4.3.1.2 Permeation

Hydrogen is more mobile and a much smaller molecule, hence more permeable than methane in many polymer materials, including the plastic pipes and elastomeric seals used in natural gas distribution systems.<sup>119</sup> The relative size of the hydrogen molecule compared to methane results in an increased permeation rate of hydrogen through PE pipes.<sup>120</sup>

A study completed shows that for new plastic piping with hydrogen concentrations up to 20%, the losses

are about 1.5-2.0 times that of methane; the report concluded that economically this was insignificant.<sup>121</sup> Hydrogen concentrations of over 20% start to exhibit noticeable losses.<sup>122</sup> For 100% hydrogen the losses are 66 times that of pure methane at 414 kPa. The losses increase exponentially with pressure increases.<sup>123</sup>

Studies completed as part of the NaturalHy project concluded no apparent significant effect on permeation coefficients in aged PE pipe.<sup>124</sup> Testing completed in America by the Gas Technology Institute also concluded that aging PE pipes seem to have no significant influence on the permeation coefficients in the experimental conditions.<sup>125</sup>

Addition of up to 10% hydrogen is unlikely to significantly increase losses due to leakage. Various projects have tested leakage rates with 10% and 20% hydrogen in natural gas and found economically insignificant levels of leakage. Depending on the condition of existing seals and joints, some replacements may be necessary to limit leakage.

#### 4.3.1.3 Elastomer seals

Elastomers have been used as mechanical coupling seals and gaskets, meter and regulator diaphragms, boots, O-rings, flange seals, valve seats, etc.<sup>126</sup> The permeation coefficient of hydrogen is higher through most of the elastomeric sealing materials that are used in natural gas distribution systems, than for natural gas alone. Natural rubber and Buna S (SBR) have less sealing ability to hydrogen compared to other elastomers.<sup>127</sup>

According to researchers in the United States, Viton A and Buna N showed greater hydrogen effects than High Density Polyethylene (HDPE) and

---

115 (Speight, 2001)

116 (EPCRC, 2017)

117 (EPCRC, 2017)

118 (Iskov, 2017)

119 (EPCRC, 2017)

120 (Messaoudani, 2016)

---

121 (Gas Technology Institute, 2010)

122 Note that testing completed by Evoenergy however, does not necessarily reflect these results.

123 (NREL, 2017)

124 (NREL, 2017)

125 (Gas Technology Institute, 2010)

126 (Altfeld, 2018)

127 (Gas Technology Institute, 2010)

Polytetrafluoroethylene (PTFE) within the scope of the experiment. With pure hydrogen exposure, elastomers exhibited a decrease in storage modulus, significant change in densities with swelling, and increased compression set (Viton A).<sup>128, 129</sup>

Thermoplastics do not exhibit significant changes with hydrogen, except for mechanical properties. Young's Modulus was 35% higher for PTFE and 15% higher for HDPE. HDPE exhibited plastic deformation; PTFE failed in the elastic region.<sup>130</sup>

For up to 10% hydrogen in the natural gas network it is expected that the losses in good condition elastomer seals through permeation will be economically insignificant and will not change the risk profile. For elastomer seals that are in average or poor conditions, particularly in aged systems, more work is required to understand the impact of up to 10% hydrogen.

#### **4.3.1.4 Recommendation for plastic piping**

It is important to consider that plastic piping systems have been used in Australian gas distribution networks for over 40 years. The plastic composition found in the networks may be different from modern plastic pipe, with the condition of some piping experiencing accelerated aging.

*It is recommended that a literature review be completed and then, if required, further investigation of the impacts of hydrogen, both technical and commercial, to aged plastic piping systems (including suitability of elastomer seals) installed in the gas distribution network be undertaken. This recommendation is required*

---

128 It is a measure of elastic response of a material and measures the stored energy.

129 (Gas Technology Institute, 2010)

130 (Brooks, 2016)

*to confirm that the addition of 10% hydrogen to aged components and piping does not impact the integrity of the pipe. As much of this work is already underway by FFCRC, it is recommended that any further action should build on this work in progress. It is expected that this recommendation will be driven by industry with support from research.*

There is much work being completed in understanding the impacts of hydrogen to plastic piping systems. FFCRC has current projects underway looking assessing the compatibility of current plastic piping which could be expanded to review aged piping. Evoenergy's tests facility is also completing tests of commonly found equipment and components with up to 100% hydrogen with promising results. This work should be leveraged where possible.

#### **4.3.2 Carbon steel piping systems**

Pure hydrogen is known to have a deleterious effect on steel toughness, fatigue life and ductility. This is known as hydrogen embrittlement.<sup>131</sup>

For pure hydrogen in high pressure application weld integrity has been identified as a risk. In a natural gas composition with low concentration of hydrogen and that is operating in a low pressure and low stress application, such as the distribution network, there is no increased risk of deterioration or reduction of integrity of the pipeline welds (providing that there are no major existing defects).<sup>132</sup>

In contrast to polymers, providing that the steel pipe is in good condition and well maintained, the permeability of hydrogen through steel is insignificant;

---

131 (Ganglook, 2012)

132 (Gas Technology Institute, 2010)



it can be considered that there is no leakage of hydrogen from a steel pipeline.<sup>133</sup>

#### 4.3.2.1 Embrittlement

A deterioration of the mechanical properties of the steel in pipelines can occur with the addition of hydrogen.<sup>134</sup> When hydrogen is present in a carbon steel pipeline, some of the hydrogen dissociates and is absorbed into the pipeline wall as atomic hydrogen.<sup>135</sup>

The absorbed hydrogen can accumulate in the steel microstructure leading to hydrogen embrittlement, manifested by a reduction in the material toughness and tensile ductility of the steel. Embrittlement reduces the steel's tolerance to defects, making the pipeline more vulnerable to failure and potentially susceptible to worse failure modes (rupture rather than leak).

In general, hydrogen embrittlement does not affect the steel's yield or tensile strength, but the reduced defect tolerance may require a reduction in allowable operating pressures.<sup>136</sup>

Many of the reported issues with hydrogen embrittlement and leakage occur when the maximum operating pressures are high (above 7 MPa) and are associated with pure hydrogen pipelines.<sup>137</sup> For a natural gas pipeline these operating conditions are more applicable to the transmission network than the distribution network.

The susceptibility of particular steels to hydrogen embrittlement depends on three factors; environment, materials and stress.<sup>138</sup> In the natural gas distribution system, the strength of steels and other ferrous alloys used is relatively low. This low strength, combined with low operating pressure and low operating stress, mean

that the steels are not particularly vulnerable hydrogen embrittlement.<sup>139</sup>

#### 4.3.2.2 Pressure cycling

Fatigue is a failure mode that occurs over time due to cyclic loading. Unlike collapse or fracture, which occur at high stress, fatigue can occur at low stress amplitudes because small incremental crack growth accumulates with each pressure cycle. Hydrogen is known to reduce fatigue life by increasing the incremental crack growth (called hydrogen-assisted fatigue crack growth, or HA-FCG).

The American Society for Mechanical Engineers (ASME) completed research in 2018 on fatigue in the presence of pure hydrogen. This work will be reflected in the next revision of *ASME B31.12 – Hydrogen piping and pipelines*. The work is based on a common fatigue crack growth model called the Paris equation, but an additional term is added to the equation when the hydrogen pressure exceeds 0.02 MPa (that pressure does not reflect the minimum at which the effect occurs, but the minimum published data). The research did not focus on low-pressure hydrogen, and did not consider hydrogen mixtures.

Pressure cycling is an unusual condition in gas distribution systems, because customers rely on receiving gas at a reliable supply pressure. Also, the fatigue life is generally very long, because the maximum stress cycle is limited by the magnitude of the operating stress. Consideration of fatigue is typically neglected in distribution system designs to *AS 4645.1:2018 – Gas Distribution Network*, in which the maximum stress is limited to less than 20% of the minimum specified yield stress. At such a low stress, if a fatigue crack forms in the pipe it may eventually leak once the crack grows through the pipe wall, but it is very unlikely to rupture because there is insufficient strain energy in the pipe material to cause the pipe to burst.

If the unique situation arises where significant pressure cycling may occur, a fatigue assessment

---

133 (EPCRC, 2017)

134 (Barthelemy, 2010)

135 (Fekete, 2015)

136 (Messaoudani, 2016)

137 (Committee on Advanced Energy Storage Systems, 1979)

138 (Bathelemy, 2005)

---

139 (EPCRC, 2017)



is still recommended, because of the deleterious effect of hydrogen on the fatigue life and toughness. Potentially, the ASME model could be applied with the hydrogen pressure substituted for the partial pressure of hydrogen in the mixture—though the validity of this approach has yet to be confirmed. Alternately, the ASME method could be applied with pure hydrogen, providing a very conservative estimate of the fatigue life. Otherwise, fatigue-life experiments could be conducted using a hydrogen-natural gas mixture on the candidate material.

The issue of fatigue will become a more critical consideration in the transmission sector, on AS 2885.1 pipelines (which may operate at higher stress) and at higher concentrations of hydrogen. HA-FCG is not expected to be a concern for distribution networks at 10% hydrogen.

#### **4.3.2.2.1 Recommendation for pressure cycling**

Pressure cycling in distribution networks with carbon steel and cast iron piping systems may cause a reduction in fatigue life.

Typically, distribution networks operate with limited pressure cycling and in a 10% hydrogen / natural gas mixture in the distribution network operating at low pressures and low stresses it would be unlikely to experience fatigue. However, further investigation is recommended to confirm that there is no increased risk.

A review of distribution network operating flows should be completed; if it is found there is significant pressure cycling in a distribution network, a literature review of the impacts of pressure cycling in low pressure with low hydrogen concentrations should be completed.

Confirmation of the pressure cycling will require input from network operators to obtain typical pressure data. The literature review could be completed by component engineers, researchers or anyone that has experience in materials.

*It is recommended that a review of network operating flow conditions be completed for distribution networks designed to AS 2885. If significant pressure cycling is found a further investigation of the impacts of pressure cycling in distribution networks should be completed in the form of a literature review. This recommendation is required to confirm there is no increased risk of fatigue due to pressure cycling. It is recommended that this action commence in the short term but conclusions should be relatively quick to determine. It is expected that this recommendation will be driven by research and industry.*

#### **4.3.3 Cast iron**

As identified in section 2.5.3 a small percentage of distribution pipes may be made of ductile iron or cast iron. These can absorb hydrogen in the same manner as linepipe grades of steel, but because of the low operating pressure in distribution networks, they are considered not to be at risk of hydrogen damage under normal operating conditions. Additionally, most installations of cast iron will continue to be replaced over time in preference for polyethylene as discussed in previous sections.

Leakage from steel and ductile iron systems mainly passes through the threads or the mechanical joints. The leakage measurements carried out by Gas Technology Institute (GTI) on gas distribution systems in the United States of America indicated that the

volume leakage rate for hydrogen is approximately three times that of natural gas.<sup>140</sup>

For 10% hydrogen by in natural gas the use of cast iron does not have any significant technical or commercial implications.

#### 4.3.4 Copper piping systems

Pure copper is resistant to hydrogen embrittlement as copper and hydrogen do not readily react under expected normal consumer piping conditions<sup>141</sup> but inclusion of oxygen in the material composition can significantly raise the level of susceptibility.<sup>142</sup> Fracture toughness of copper does not appear to be affected by exposure to hydrogen.

No copper piping systems have been identified in our review of the gas distribution systems within Australia. Copper is used between the connections of the distribution network to the appliance, the design of which is under covered under *AS/NZS 5601.1:2013 – Gas Installations – General Installations*.<sup>143</sup> A recommendation has been made to review the impacts to AS/NZS 5601.1 as part of this report.

### 4.4 Safety and Risk

The natural gas industry has a well-established approach to safety, due to the significant hazards that exist. Natural gas poses heat and explosion hazards, due to the chemical energy (flammability) and compression energy (expansion after release from pressure vessels or pipework) of the gas. It can also pose an asphyxiation hazard to individuals, if it accumulates in an enclosed space. Due to the inherent risk, safety is a key consideration across all sectors of the gas industry.

Pure hydrogen has several properties that would require a change in approach to safety. These include having a colourless flame, being incompatible

with odorants used in natural gas, high ignition frequency, broad flammability limits, and a positive Joule-Thompson coefficient (that is, it heats up when expanding, whereas natural gas cools down).

In a lean-hydrogen mixture, the impacts on safety are more manageable, as the change to the gas characteristics are marginal. As discussed above, a lean gas mixture is more buoyant, has a reduced heating value (energy density), a marginally reduced lower explosive limit (about 1% reduction), and different flow characteristics possibly leading to a faster leak rate.

These effects combined will marginally change the parameters used for quantifying risk, but the change will generally not be sufficient to require modification to current practices. The following safety philosophies are a function of the gas characteristics and composition, and are discussed in detail:

1. **Hazardous areas.** These are exclusion zones around equipment within which electrical devices are not permitted as classified and detailed in the AS/NZS 60079 series of standards.
2. **Worker safety.** Gas industry workers are afforded layers of protection from a range of safe work procedures and training, including personal protective equipment, clothing standards, use of gas detectors, isolation principles and similar.
3. **Gas detection.** Automated leak detection and gas detection systems are used, especially in commercial and industrial contexts where there are large inventories of gas or high flow-rates, to automatically identify an incident while it is occurring and enact mitigation systems (shut-downs, evacuations and similar).
4. **Leaks in enclosed spaces.** In distribution systems, the consequence of a release escalates if the leak is able to accumulate in an enclosed space, like a building basement.
5. **Radiation contours.** Particularly in the pipeline industry, the potential radiation zone from an ignited leak or rupture is used to estimate the affected infrastructure and population, as an input to consequence modelling and risk rating.

---

140 (Gas Technology Institute, 2010)

141 (Bathelemy, 2005)

142 (San Marcki, 2008)

143 (Standards Australia - AS/NZS 5601, 2013) Page 5

6. **Odorant.** Humans are unable to smell either methane or hydrogen. The natural gas industry adds odorant to the gas, in order that domestic leaks will be detected rapidly.

The following sections consider the safety impacts and considerations for these five items presented by injecting concentrations of up to 10% hydrogen into the natural gas distribution network.

#### 4.4.1 Hazardous area

A hazardous area is a three-dimensional space around pressure equipment (particularly joints and vents) in which a flammable atmosphere may be present. Outside the hazardous area, the gas concentration is expected to be below 50% of the lower explosive limit (LEL). Special precautions are required to prevent ignition sources within the hazardous area, which affects any construction, installation and use of electrical equipment.<sup>144</sup>

Hazardous areas are a function of leak rate and dispersion (driven by buoyancy and mixing) and the LEL, which varies for different compositions. Consequently, modification of the gas composition could have an impact on the size of a hazardous area.

Modelling was conducted using DNV GL PHAST8, to simulate leaks from a pressure vessel. The modelling used a range of typical Australian gas compositions, with 10% hydrogen. Table 12 provides a summary of the outputs, and shows that, excluding NT Typical, the dispersion distance to achieve 50% of LEL was increased by approximately 3% with the addition of 10% hydrogen.

Although there is no formal reference in standard industry practice, a 3% increase in hazardous area is insignificant, because hazardous radii are generally rounded to the nearest 0.5 or 1.0 m.

For blends of up to 10% hydrogen in a natural gas distribution system it is envisaged that the existing hazardous area sizing guidelines presented in AS/NZS 60079.10 will remain applicable.

---

144 (Work Cover Queensland, 2019)

The impact on the classification of the resultant gas mixture due to the presence of higher percentages of hydrogen in accordance with AS/NZS 60079 may also be affected and this is further discussed in section 5.4.2.1.

#### 4.4.2 Worker safety

Hydrogen has a lower explosive limit than natural gas, and is also known to have a high frequency of ignition—meaning that gas leaks are more likely to ignite. This is not expected to be a concern for lean hydrogen blends such as are considered in this report, but it would require consideration for higher quantities of hydrogen.

For concentrations of up to 10% hydrogen the established methods for managing worker safety are still applicable without modification.<sup>145</sup>

---

145 (EPCRC, 2017)

**Table 12** Dispersion Model Results

	H <sub>2</sub>	50% LEL*	PPM	Distance (m)	Δ
<b>SA/NSW Moomba</b>	0%	2.21%	22,100	1.50	0.04m (2.7%)
	10%	2.19%	21,850	1.54	
<b>QLD Gladstone</b>	0%	2.23%	22,300	1.50	0.04m (2.8%)
	10%	2.21%	22,050	1.54	
<b>VIC/TAS Longford</b>	0%	2.17%	21,700	1.50	0.04m (2.7%)
	10%	2.16%	21,550	1.54	
<b>WA W LPG Plant</b>	0%	2.28%	22,750	1.46	0.05m (3.5%)
	10%	2.25%	22,450	1.51	
<b>NT Typical</b>	0%	2.20%	22,000	1.51	-0.04m (-4.0%) <sup>†</sup>
	10%	2.32%	23,200	1.45	

\* 50% Lower Explosive Limit (LEL) in air concentration.

† The high nitrogen levels in the Northern Territory cause reduction in dispersion distance.

### 4.4.3 Gas detection

#### 4.4.3.1 Personal

Not all personal gas detectors currently in use will detect hydrogen, but they will detect the mole fraction of the methane component. Industry practice is to set the device alarm at 50% of LEL, which is about 2.5 mol% methane. If the gas source is changed to be 10% hydrogen this will:

- Decrease the methane proportion by up to 10%; and
- Decrease the LEL by about 1%.

Consequently, the margin of safety afforded by the device alarm will be narrowed from 50 %LEL to about 43 %LEL, but this will still provide advance warning that the gas concentration is approaching flammable limits, providing workers opportunity to respond safely.

#### 4.4.3.2 Stationary

Accurate gas detection is a fundamental requirement for the safe operation of a gas distribution network.<sup>146</sup> Certain industrial users may have gas detection instrumentation designed to shut down and/or isolate sections of plant when the concentration of an explosive gas mixture in air reaches a fraction of LEL.

Gas leak detection devices designed for natural gas may not be accurate for mixtures of natural gas and up to 10% hydrogen. Some gas detection devices will be more sensitive for hydrogen than for natural gas while others are not sensitive to hydrogen at all and will only detect to the methane content. For detecting both hydrogen and methane, leak detection devices using semiconductors are generally considered suitable.<sup>147</sup>

Instruments that are unable to detect hydrogen need to be identified and where possible calibrated to identify a lower level of methane. Detection instruments that are unable to detect hydrogen, even if calibrated, should be replaced.

There are further issues if the blend changes or has a larger variability than 10% as the gas detection systems are static and would not dynamically change to suit the blend.

For 10% hydrogen in the natural gas distribution network, a review the suitability of existing gas detection instrumentation and set points is required. However generally gas detection is based on accurately detecting a gas mixture based on calibration with a known gas such as methane or ethane and as such there is always variability in the actual measured

146 (Isaac, 2019)

147 (EPCRC, 2017)

flammable gas concentration of actual gas mixtures. Alarm limits are often set well below actual LEL at 5-10% for alarming purposes and often at values such as 40% of the LEL for automated shutdown and isolation systems. Based on this it is unlikely concentrations of up to 10% hydrogen will impact the effectiveness of gas detection systems.

#### **4.4.3.3 Recommendation for gas detection devices**

As outlined above, hydrogen in gas detection devices can lead to improper operation or non-detection of a hazardous atmosphere. Before injecting hydrogen into a gas distribution network current individual gas detection devices installed on the network should be assessed for suitability. This process will include an audit of the models that are currently used in the distribution network and an assessment of suitability.

For 10% hydrogen in natural gas mixture it is generally accepted that gas detection devices will be able to be recalibrated.

For this recommendation, involvement of gas distribution network operators and gas detection manufacturers will be required along with engineers (or other component personnel) to complete the assessment.

*It is recommended that a review of the technical suitability of gas detection equipment installed and used in the distribution network for up to 10% hydrogen be completed. This recommendation is required because hydrogen can lead to improper operation or non-detection of hydrogen. This is a medium term action as pilot facilities are currently assessing on a case-by-case basis,*

*but broader understanding will be required as hydrogen utilisation in the distribution networks increases. It is expected that this recommendation will be driven by industry (both network operators and equipment manufacturers) with support from research.*

#### **4.4.4 Gas build-up in buildings**

Accumulation of gas in building is considered a major risk. Hydrogen has the potential to change the risk profile due to the wider flammability range, lower ignition energy, and higher mobility of the gas.

The HyDeploy study found that the dispersion characteristics and relative leak rate of natural gas containing up to 20% hydrogen to be comparable with natural gas. As discussed in Section 4.4.1 a 10% hydrogen blend will result in only a 3% increase in the extent of the hazardous area, which is considered insignificant. Therefore the risk profile is not noticeably different for 10% hydrogen in natural gas blend provided that upon the release separation does not occur.

The NaturalHy study investigated build-up behaviour in two experimental releases for increasing hydrogen blends, in a smaller room representative of domestic dwellings and another in a larger room, representing a commercial or industrial building. The study observed that no separation of hydrogen from the mixture occurred. In general, the steady-state concentration following a release is only slightly higher for blends of up to 50% hydrogen, but concentration increases become more significant for hydrogen blends greater than 70%.<sup>148</sup>

Based on the above, gas build-up in buildings for 10% hydrogen in natural gas blend in domestic or industrial

---

<sup>148</sup> (NREL, 2017)

premises is similar to natural gas and does not present a major change in risk.

#### **4.4.5 Air dilution rates in enclosed spaces**

Gas leaks in enclosed spaces are characterised by initial stratification (the more buoyant hydrogen gas initially accumulates at the top of the space) and subsequent slow dilution (gases mixing over time). Given the density similarity between natural gas and natural gas with 10% hydrogen, this propensity remains.<sup>149</sup>

In some enclosures, the potential for flammable gas accumulation is controlled with forced ventilation, and others with natural ventilation. For such enclosures there would need to be calculated demonstration that the forced air change frequency or natural ventilation airflow area is adequate. The main reason for this is that the maximum possible leak rate might be higher, because any devices using a hydrogen blend may require higher flow rates due to the reduced gas efficiency (reduced HHV).

The adequacy of any existing decompression shutters or explosion dampers will need to be checked, as the flame speed factor for the 10% hydrogen mixture is marginally higher. However, the maximum pressure achieved in the specific enclosure is a function of total energy available and its volume, and this will be lower due to the lower HHV of the hydrogen gas blend.

#### **4.4.6 Radiation and dispersion distance**

Radiation contours are used in the pipeline industry to determine the largest area in which infrastructure and people may be affected by an ignited gas leak. This informs consequence modelling and hence risk ranking for public safety.

Plume modelling software<sup>150</sup> was used to determine relative effects of hydrogen content on radiation contour models for pipeline rupture and leak scenarios. The results obtained for radiation contour distance

were also compared to the method provided in AS 2885.<sup>151</sup>

A DN160 HDPE pipeline with 14.6 mm wall thickness operating at 350 kPag was modelled using typical Australian gas compositions, with and without 10% hydrogen. The results are provided in Table 13 below, and show that there is typically a small reduction in both flame length and the radiation contour with the 10% hydrogen gas blend. The Northern Territory composition was an exception, with an increase in flame length.

The risk assessment process that is used for public safety on pipelines provides a large degree of conservatism. Consequently, a change of 0.3m is not significant. (Note also that these results deviate from the results found in AS 2885.6 Appendix B; this is likely due to different modelling assumptions relating to wall roughness and similar, and is inconsequential).

---

151 (Standards Australia - AS 2885.6, 2018) Appendix B

---

149 (Marangon, 2011)

150 DNV GL PHAST8



**Table 13** Results of Contour Model

	H <sub>2</sub>	Flame Length	Distance to 4.7 kW/m <sub>2</sub>	Distance to 12.6 kW/m <sub>2</sub>
<b>SA/NSW Moomba</b>	0%	25	37	31
	10%	24	36	30
	Δ	-0.7 (3.0%)	-1.1 (3.2%)	-0.9 (3.1%)
<b>QLD Gladstone</b>	0%	25	36	31
	10%	24	35	30
	Δ	-0.7 (2.9%)	-1.1 (3.2%)	-0.9 (3.1%)
<b>VIC/TAS Longford</b>	0%	25	37	31
	10%	24	36	30
	Δ	-0.7 (3.0%)	-1.2 (3.3%)	-0.9 (3.2%)
<b>WA South Metro</b>	0%	25	37	31
	10%	24	35	30
	Δ	-0.7 (3.0%)	-1.1 (3.2%)	-0.9 (3.1%)
<b>NT Typical</b>	0%	25	36	31
	10%	25	36	30
	Δ	+0.2 (0.8%)	-0.7 (2.1%)	-0.5 (1.7%)

#### 4.4.7 Odourisation

Addition of a chemical substance is required in a natural gas distribution network to enable it to be detected by smell. Similar to that of 100% natural gas, pure hydrogen is odourless and will require an odorant be added to the system. Selecting the specific odorant to be injected involves knowledge of:

- the chemical composition of the gas;
- the physical and chemical characteristics of available odorants;
- the physical layout of the pipeline system and buffer storage tank (if applicable);
- ambient conditions;
- the need to be able to identify the specific gas (e.g. natural gas vs liquid petroleum gas vs hydrogen etc.);
- the desired odorant level; and

- recognition of the local population's current sensitivity to odorant.<sup>152</sup>

Typically for gas distribution networks, odorant level is required to be detectable at a minimum of one fifth the lower flammability limit (or lower explosive limit) of the gas composition.<sup>153</sup> This requirement varies by state and is discussed further in the regulatory review section of this report. The typical natural gas odorisation is a blend of 70% tetrahydrothiophene (THT) and 30% tertiary butyl mercaptan (TBM), injected into the gas stream at a 14 mg/m<sup>3</sup> of gas (this is also dependant on the network).<sup>154</sup> This gas odorisation regime has traditionally been considered adequate to meet the requirements of the Gas Safety (Gas Quality) Regulations.<sup>155</sup>

<sup>152</sup> (Parrott, 2017)

<sup>153</sup> (Standards Australia - AS 4564, 2011)

<sup>154</sup> (AEMO, 2017)

<sup>155</sup> (AEMO, 2017)

The impact of that odorant has on fuel cells has been widely discussed. Sulphur is a major issue for fuel cells; even small concentrations will poison the catalyst, which leads to degradation.<sup>156</sup> For a distribution network, with only a small level of sulphur that has fuel cell applications such as refuelling, the odorant will need to be removed. Currently, there is no commercially available odorant suitable for use in a fuel cell, but research is being completed to develop a suitable option. Importantly, any new odorant for hydrogen must be distinct and not smell similar to natural gas.

The gas distribution network operator will need to review their odorant injection strategy and determine whether it is necessary to increase odorant injection rates to account for the dilution effect of blending with hydrogen. Consideration will need to be given to the odorant injection location and hydrogen injection location in order to avoid overdosing odorant in non-hydrogen blended sections of the network.

Based on dilution of the odorised natural gas by 10% hydrogen, it is necessary that natural gas odorant levels be maintained the 14 mg/m<sup>3</sup> level.<sup>157</sup> However, the current levels of odorant in the network generally exceed the required levels and no modifications to existing levels would be required.

Technically, there is no known chemical incompatibility issues of note between hydrogen and the odorising compounds commonly used in natural gas. Hydrogen should therefore have no deleterious interaction with odorants.<sup>158</sup> The injection point of the odorant is important if the hydrogen / methane mixture is going to be used in sulphur-sensitive applications or to re-extract hydrogen from the pipeline to use in hydrogen-specific applications. In this case, sulphur containing odorants would require removal prior to use; or acrylate odorants used.<sup>159</sup>

## 4.5 Summary of key considerations for regulations & standards

Table 14 gives summary of the impacted standards and regulations and associated implications when 10% hydrogen is added to natural gas in the distribution network.

---

156 (Imamura, 2007)

157 Appendix 2 – Gas Composition Calculation

158 (Health and Safety Laboratory, 2015)

159 (Health and Safety Laboratory, 2015)

**Table 14** Summary of implications and recommendations for 10% hydrogen in natural gas

Property	AS 4564	AS/NZS 4645	AS 2885	AS/NZS 60079	Regulations	Summary of impacts
Gas Composition	X	X	X	X	X	Gas composition changes to 10% hydrogen and 90% natural gas.
Higher Heating Value (HHV)	X				X	For a typical natural gas composition with 10% hydrogen in Australia the HHV decreases approximately 6-8%.
Specific Gravity (SG)	X					For a typical natural gas composition with 10% hydrogen in Australia the SG decreases approximately 10%.
Wobbe Index (WI)	X					For a typical natural gas composition with 10% hydrogen in the WI decreases approximately 2%.
Methane number (MN)						For 10% hydrogen / 90% methane blend the methane number reduces by 10%.
Flame speed factor						For a typical natural gas composition with 10% hydrogen in Australia the flame speed may result in an increase of approximately 10%.
Sooting Index (SI)					X	For a typical natural gas composition with 10% hydrogen in Australia the sooting index may result in a decrease of approximately 10%.
Flammability limit		X	X			For a typical natural gas composition with 10% hydrogen in Australia the UFL will increase slightly and LFL will decrease slightly, resulting in a slight widening of the flammability range.
Flame emissivity						For a typical natural gas composition with 10% hydrogen the flame emissivity is similar to that of 100% natural gas.
JT cooling effect						For a typical natural gas composition with 10% hydrogen in Australia the JT cooling effect is similar to that of 100% natural gas.
Minimum ignition energy (MIE)				X		For a typical natural gas composition with 10% hydrogen it is expected that the MIE will be similar to that of a pure methane blend although the actual value has not been determined.
Auto ignition temperature		X				For a typical natural gas composition with 10% hydrogen the auto ignition temperature is similar to that of pure natural gas.
Moisture vapour	X				X	For a typical natural gas composition with 10% hydrogen it is expected an increase in moisture vapour of approximately 3% during combustion.
Network capacity		X				For a typical natural gas composition with 10% hydrogen in Australia a capacity reduction of approximately 2-3% is likely.

Table 14 continued

Property	AS 4564	AS/NZS 4645	AS 2885	AS/NZS 60079	Regulations	Summary of impacts
Injection location		X				Impacts are likely to be minimal with blending rates up to 10%, but injection points will require planning and modelling on a case-by-case basis.
Stratification		X				Stratification in piping downstream of hydrogen injection does not require consideration.
Measurement and metering of gas		X	X		X	Consideration should be given to the type of sampling equipment in an existing natural gas distribution system and requirements set out in standards and regulations.
Plastic Piping		X				For 10% hydrogen by in natural gas the use of modern plastic piping in good condition does not have any significant technical or commercial implications.  For aged plastic piping systems it is recommended more work be completed to confirm suitability.
Steel Piping		X	X			For 10% hydrogen by in natural gas the use of steel piping system in good condition does not have any significant technical or commercial implications.  It has been reported that a reduction of fatigue life due to pressure cycling may be seen in steel piping systems. It is recommended that this be reviewed.
Cast Iron		X				For 10% hydrogen by in natural gas the use of cast iron does not have any significant technical or commercial implications.
Copper Piping		X				For 10% hydrogen by in natural gas the use of copper does not have any significant technical or commercial implications.
Hazardous Area		X	X	X		For blends of up to 10% hydrogen in a natural gas distribution system the existing hazardous area sizing will remain applicable.
Workers safety		X	X		X	For concentrations of up to 10% hydrogen the established methods for managing worker safety are still applicable without modification.
Gas Detection		X			X	For 10% hydrogen in natural gas mixture it is generally accepted that gas detection devices will be able to be recalibrated.  It is recommended that a review the suitability of existing gas detection devices and their set points is completed.

Table 14 continued

Property	AS 4564	AS/NZS 4645	AS 2885	AS/NZS 60079	Regulations	Summary of impacts
Gas build-up in buildings		X		X		Gas build-up in buildings for a 10% hydrogen in natural gas in domestic or industrial premises is similar to natural gas and does not present a major change in risk.
Air dilution rates		X				The adequacy of any existing decompression shutters or explosion dampers will need to be checked, as the flame speed factor for the 10% hydrogen mixture is marginally higher.
Radiation and dispersion		X	X	X		Typically a small reduction in both flame length and the radiation contour with the 10% hydrogen gas blend. The NT composition was an exception, with an increase in flame length. No increased risk over pure natural gas.
Odourisation		X			X	Based on dilution of the odourised natural gas by 10% hydrogen, it will be necessary to increase the minimum existing natural gas odourant levels to maintain the 14 mg/m <sup>3</sup> level.

# 5 IMPLICATIONS FOR AUSTRALIAN STANDARDS

This review assesses the addition of 10% hydrogen to natural gas distribution networks to relevant Australian Standards. This review uses the impacts and considerations identified in earlier in the report as a basis for review. The review identifies barriers in the current technical standards and provides recommendations to overcome them.

This study does not include review of AS/NZS 5601, which is applicable to consumer piping downstream of the outlet of the consumer billing meter installation, which is outside the scope of this study. The scope of AS/NZS 5601 covers the design, installation and commissioning of gas installation associated or intended with the use of fuel gases, natural gas, LP Gas, simulated natural gas, or biogas.<sup>160</sup> This review also does not include appliance standards such as AS 3645, AS 3814 and AS 5263. As discussed earlier it is recommended that these standards be reviewed as further work.

## 5.1 AS/NZS 4645 Series – Gas Distribution Networks

AS/NZS 4645 series is applicable to gas networks operating at less than or equal to 1050 kPa and is currently used across Australia in natural gas distribution networks. Part 1 covers the requirements for network management (including reference to related standards for Safety, Risk, etc.). Part 2 is applicable to metallic networks, and Part 3 applies to non-metallic (plastic) networks. *AS 4809:2017 – Copper pipe and fittings – Installation and commissioning* is used in conjunction with the 4645 series and applies to copper mains and services.<sup>161</sup>

---

160 (Standards Australia - AS/NZS 5601.1, 2013) Section 1.1

161 (Standards Australia - AS 4809, 2017)

### 5.1.1 Current Distribution Network Methodology

The AS/NZS 4645 standard series adopt a performance-based approach for gas distribution network management. This methodology recognises that one standard may not be the best fit for all networks. It also allows innovation and development in the way gas distribution networks are managed, operated and maintained. Performance-based standards aim to specify safety outcomes while still allowing flexibility.

The AS/NZS4645 series of standards:

1. Provides performance-based requirements for gas distribution network safety, defining important principles during the lifecycle of gas distribution networks;
2. Provides prescriptive means of conformance in support of some of those performance-based requirements; and
3. Allows for alternatives means of conformance that may be also acceptable provided the required safety outcomes can be demonstrated.

This standard series takes a risk management approach in accordance with *AS/NZS ISO 31000 - Risk Management – Principles and Guidelines*. Risks associated with the gas distribution network are required to be at acceptable levels with respect to any loss of supply of gas and any threats from escaping gas, throughout the life of the gas distribution network. *AS4645.1:2018 – Gas distribution networks – Network management* describes the use of a Safety and Operating Plan is used to ensure that all risks associated with the design operation and maintenance of a gas distribution network are identified and appropriately managed.<sup>162</sup>

---

162 (Standards Australia - AS/NZS 4645.1, 2018)



## 5.1.2 Specific Considerations for Hydrogen

### 5.1.2.1 Concentration up to 15% hydrogen

AS/NZS 4645.1 was updated in 2018 to provide guidance to network operators on an upper limit of hydrogen in distribution networks. The standard does not apply to transport of mixtures in excess of 15% hydrogen.<sup>163</sup> However this exclusion is not intended to allow *up to* 15% without assessment of the impacts of hydrogen and is contingent on the assessment of associated risk being management to a level that is acceptable.

AS/NZS 4645.1 Section 3.3.2 requires the relevant gas specification standard (AS 4564 or AS 4670) should be adopted wherever possible. It also states that an alternative gas specification may be used for distribution gas networks after a suitability assessment. Where an alternative specification is adopted, a Formal Safety Assessment (FSA) shall confirm suitability of all controls including those provided by means of conformance. The intent of this is to provide flexibility for the varying natural gas qualities in Australia.

### 5.1.2.2 Network Performance

A 10% hydrogen blend has a lower energy density by volume. To achieve an equivalent energy density the energy flow rates of the pipeline is required to be increased. For distribution networks that are currently operating at or near the maximum allowable operating pressure (MAOP) and are currently capacity constrained, this may present a supply issue due to the reduction in capacity introduced by hydrogen.

Note that AS/NZS 4645.1:2018 3.5.1 gives a method for uprating the MAOP of parts of the distribution network, but whether this is feasible will depend on the specific design and testing completed on an existing line and require assessment on a case by case basis.

---

<sup>163</sup> (Standards Australia - AS/NZS 4645, 2011) Section 1.2 (d)

### 5.1.2.3 Materials, joints and sealing

AS/NZS 4645.1 section 4.5 specifies the materials and equipment used in construction, maintenance and operation of the gas distribution network, including pipe, fittings and jointing. Materials specified in AS/NZS 4645.1 Table 4.1, AS 4809, AS 4041, AS/NZS 4645.2 and AS/NZS 4645.3 are considered fit-for-purpose when applied as intended. Table 4.1 covers piping and components manufactured from cast iron, carbon steel, galvanised steel, copper, stainless steel, polyethylene, polyamide and polyvinyl chloride. As discussed in this report, these materials are generally compatible with hydrogen at a 10% blend for the pressures allowed under the standard without concern.

*AS/NZS 4645.3:2008 – Gas distribution networks – Plastic pipe systems*, specifies polyethylene (PE80B and PE100), polyamide and polyvinyl chloride pipe materials for gas service.<sup>164</sup> Section 4.3.1 of this report has identified that, providing this material is in good condition, these materials are generally suitable for a 10% hydrogen blend with low risk of degradation and a tolerable permeation rate. It has been recommended that joints, seals, and fitting be confirmed for hydrogen suitability in section 7.1 but they are expected to be suitable for 10% hydrogen.

*AS/NZS 4645.2:2008 – Gas distribution networks – Steel pipe systems*, covers a number of pipe standards, generally covering cast iron and lower strength grades of carbon steel, including ASTM A106, API Spec 5L (grade X52 and lower).<sup>165</sup> At the low stress allowed under the code (a maximum of 20% SMYS as per AS/NZS 4564.2 clause 3.4.1.2) the specified materials are expected to be suitable for a 10% hydrogen service.

However, for both the plastic pipe systems and steel piping systems, the referenced material standards listed in AS/NZS 4645 parts 1, 2 and 3 have not undergone a detailed review. While it is the responsibility of the designer to ensure that materials are compatible for the service e.g. hydrogen; it is recommended that a review of materials listed in Table 4.1 compatibility for

---

<sup>164</sup> (Standards Australia - AS/NZS 4645.3, 2008)

<sup>165</sup> (Standards Australia - AS/NZS 4645.2, 2008)

hydrogen be completed to minimise the barriers to hydrogen injection. This review and update would be driven by the standards committee responsible for AS/NZS 4645 and would require results from current research. It could be completed during the next revision cycle.

#### **5.1.2.4 Safety and Radiation Zone**

AS/NZS 4645.1 4.7.2 specifies that the maximum energy release rate for the largest credible defect in high density community use area shall be restricted by the design to less than 1 GJ/s after 30 seconds. For 10% hydrogen in natural gas blend it has been identified in 5.3.3.5 that the radiation contour zone is slightly reduced and meets the 1 GJ/s after 30 second requirement. The current methodology for calculating energy release rate is suitable for up to 10% hydrogen concentrations.

#### **5.1.2.5 Construction and commissioning**

AS/NZS 4645.1 4.7.2 Section 5 outlines the construction, testing and commissioning requirements in the distribution network. Construction techniques are expected to be similar. Testing equipment for commissioning and testing should be confirmed for suitability of hydrogen.

Commissioning should utilise existing techniques but considerations for varying risks of hydrogen should be made. Hydrogen is susceptible to spontaneous ignition when released into air at relatively low pressure.<sup>166</sup> Recent research indicates that blends with natural gas significantly desensitise the mixture to spontaneous ignition, and ignition of a 10% hydrogen blend is unlikely.<sup>167</sup>

The varying properties and characteristics of the 10% hydrogen blend should be considered during purging and flaring.

AS/NZS 4645.1 section 6.2.2 (c) specifies that any significant change in the composition of the gas in the system, tests shall be carried out to ensure the gas

odour is in accordance with the requirements of AS/NZS 4645.1.<sup>168</sup>

AS/NZS 4645.1 section 16.4 outlines the process to minimise the risks of changing gas compositions outside the limits specific in the SAOP. For a 10% hydrogen blend it is unlikely the composition will be outside of limits in AS 4564, which would be expected to be generally used in the SAOP.

AS/NZS 4645.1 section 6.4 specifies the leak management process for the distribution network. As hydrogen is a smaller molecule, there may be concerns that the chance of leakage is increased at the molecular level or that leakage out of flanges and joints might also be increased. Review and compliance with this section would be required if 10% hydrogen is added to the natural gas network. Consideration should be given to the density of the hydrogen versus air. 6.5.3 (A) does include a method for testing gases other than natural gas and LPG. It is expected that a hydrogen blend will be testable under this clause.

Where changes are required to the operating conditions or equipment upon the addition of hydrogen, a review of the changes should be completed against AS/NZS 4645. The change management process in AS/NZS 4645 should be followed.

AS/NZS 4645.1 Section 9 outlines the emergency response planning and incident investigation. Gas composition is required to be considered as part of the section but the addition of 10% hydrogen does not affect the standard. Upon addition of 10% hydrogen this section should be considered but no immediate modification to the standard is required.

Appendix A covers the requirements of distribution networks operating above 1050 kPa. AS/NZS 4645.1 states that any distribution network operating above 1050 kPa shall be designed to AS 2885. AS 2885 has been reviewed as part of this study and the

---

166 (Astbury, 2008)

167 (Rudy)

---

168 Note that this would be in addition to the requirements of any applicable jurisdictional legislation.

recommendations and areas for further research are considered applicable for this section.

The applicability of Appendix N Table N1 for a gas composition that is outside the specification of AS/NZS 4564 should be confirmed.

### **5.1.3 Recommendation for AS/NZS 4645**

AS/NZS 4645 is used when designing and operating a natural gas distribution network below 1050 kPa. A high level review of the standard was completed. While the standard prescribes an upper limit of 15% hydrogen (by volume) which exceeds the 10% investigated in this study it is understood that a thorough review of the standard was not completed which assessed the impacts of hydrogen in general.

The standard was also assessed with consideration of the impacts of 10% hydrogen from a high level and minor work is recommended to confirm the suitability of such a blend. In general, due to the low stress (<20% SMYS) and pressure (<1050kPa) allowed under the standard the materials listed in the are generally accepted as suitable for a 10% blend, or higher, based on the existing research and studies in this area. The work that FFCRC is completing including research into testing of plastic and steel piping, as well as the phase 1 testing of Australian network components, construction and maintenance practices from Evoenergy's hydrogen test facility project should be leveraged to verify this. Additionally a number of parallel studies and international projects are also providing confidence of compatibility for materials under AS/NZS 4645 in hydrogen service.

During the 2018 revision of AS/NZS 4645.1 a clause that clarifies the scope of the standard to exclude "transport of mixture of gas with hydrogen content in excess of 15% by volume" was included.<sup>169</sup> This inclusion effectively serves to enable consideration of network operation with a percentage of hydrogen included, **provided all other requirements of the standard are met**. This would logically include compliance with

<sup>169</sup> (Standards Australia - AS/NZS 4645.1, 2018) Section 1.2(d)

standards to which AS/NZS 4645.1 refers. As part of the recommendation the standards that are called upon as part of the AS/NZS 4645 series should be reviewed with consideration of the technical, commercial, and regulatory impacts, and risks associated with introduction of a 10% hydrogen blend.

AS/NZS 4645 is set up with the structure of a performance based (risk based) overarching process (primarily Part 1) and a series of prescriptive elements (Part 2 and Part 3 and some of the requirements in Part 1). Further review of the prescriptive elements of the AS/NZS 4645 standards series should be undertaken to consider the implications of addition of up to 10% hydrogen into the distribution network. For consistency, a review of up to 15% hydrogen by volume may be beneficial.

*It is recommended that a detailed review and update of the AS/NZS 4645 series for compatibility of hydrogen up to 10%, including referenced standards, be completed. This recommendation is required to provide clarity and improve the safety of future hydrogen injection projects. This action is only required in the medium term and should be captured during the next standard revision. It is expected that this recommendation will be driven by the standards committee (AG-008) but will require support from industry and research.*

Amendments or updates to the standard could be approached in a method similar to the LP Gas distribution suite of standards. Requirements for specific gas mixtures and gases could be derived in the standard. In addition, any changes to the standard

would be based upon recommendations from research and experience both domestically and overseas. Current research in materials, appliances, and risk and safety being completed by the FFCRC would be valuable contributions to this process.

Although the current wording of the standard does not provide a hard barrier, it is suggested that a review and update of AS/NZS 4645 series of standards be completed by the standard committee to ensure the outcomes of the research and testing undertaken are applied to the standard for design, construction, testing & commissioning, and the referenced material standards are acceptable. The scope of the standard revision should also carefully consider concentrations above 10% to reduce barriers to hydrogen in the gas networks.

## 5.2 AS 4564 – Specification for general purpose Natural Gas

AS 4564:2011 – Specification for general purpose natural gas serves as a specification for general purpose natural gas, with an emphasis on the safety of the gas for use in natural gas appliances and equipment and for use as fuel in natural gas vehicles.<sup>170</sup>

### 5.2.1 Purpose and methodology

The quality specification provided by AS 4564 defines the requirements for providing a natural gas suitable for transportation and for general purpose use and provides the range of gas properties consistent with safe operation of the natural gas appliance population.

---

170 (Standards Australia - AS 4564, 2011) Section 1.1

AS 4564 defines **general purpose natural** gas as:

***“Natural gas that is suitable for transportation in transmission and distribution systems, and which is safe for use in the general population of natural gas appliances and equipment in Australia, and (possibility subject to additional limits) suitable for transportation in transmission systems.”***

(Standards Australia - AS 4564, 2011) Section 1.6.1

It also defines **natural gas** as:

***“A gaseous fuel consisting of a mixture of hydrocarbons of the alkane series, primarily methane but which may also include ethane, propane and higher hydrocarbons in much smaller amounts. It may also include some inert gases, plus minor amounts of other constituents including odorizing agents. Natural gas remains in gaseous state under the temperature and pressure conditions normally found in service.”***

(Standards Australia - AS 4564, 2011) Section 1.6.6

The main purpose of the specification is to:

- Ensure the gas is safe and suitable for using in gas burning appliances.
- Provide certainty for appliance manufacturers who supply appliances for use in the Australian market.
- Ensure the products of combustion are not toxic or hazardous to health other than the normal combustion products.
- Ensure the integrity of the transportation system is maintained by setting limits for contaminants.
- Provide a normative guide for contracts between buyers and sellers of natural gas.

## 5.2.2 Development of AS 4564

Historically, natural gas was reticulated into each state-based transmission and distribution system; this gas was obtained from separate production sources and had varying compositions. A uniform specification was required to enable gas to be traded in a manner that does not adversely affect the current and future stakeholders involved in the entire gas utilisation process.<sup>171</sup>

In developing the AS 4564 Standard AG-010 referred to, and drew from, *NZS 5442:1999: Specification for reticulated natural gas*. It is interesting to note that NZS 5442 gives a maximum hydrogen content of 0.1 mol%. The maximum hydrogen limit is imposed because at the time minimal research of impact of gas appliances it was thought that excess hydrogen content caused burner light back. The maximum hydrogen limit was not included as part of the Australian version of the standard which was released in 2003.

AS 4564 is also in general agreement with other international standards such as Northern California: PG&E Rule 21, Southern California: SOCALGAS Rule 03, and NZS 5442.<sup>172</sup>

---

171 (Blogg, 2003)

172 (Gas Industry Company Limited, 2007)

Since its initial development in 2003, AS 4564 has undergone two revisions in 2005 and 2011. The 2011 revision included the addition of a maximum HHV of 42.3MJ/Sm<sup>3</sup> to the specification limits. Previous to this it was expected that all gas available would be in the range of 37MJ/Sm<sup>3</sup> to 42MJ/Sm<sup>3</sup>. A draft review of AS 4564 will be prepared in 2019, and is expected to be released for use in 2020. In addition to minor terminology updates the new revision is expected to review limits for sulphur and radioactivity set out in Table 3.1.

## 5.2.3 Specific considerations for hydrogen

### 5.2.3.1 Definitions and Application

Section 1.1, states that the scope of the standard applies to natural gas that is from petroleum, landfill, biogas, coal seam and other sources where these sources provide gas for direct or blended supply.

This scope and definition does not easily extend to a 10% addition of hydrogen, which is not a hydrocarbon of the alkane series, or inert or a quantity to be considered a 'minor amount'. It is recommended the scope and definitions be broadened to more easily allow for hydrogen use, that in a blend meet the other requirements of the standard.

### 5.2.3.2 Limits and departures

In order to retain the greatest flexibility of supply there is no attempt in the standard to detail the composition of the gas.

Through this omission, notwithstanding the limitations in the scope and definitions, it is inferred that any gas composition that is within the bounds of the characteristic and components limits expressed in AS 4564 Table 3.1 should be suitable for use in networks that are required to comply with AS/NZS 4645.

Table 15 is a comparison between of typical standard natural gas compositions found across Australia and the same compositions with 10% hydrogen added; it also include the limits set in AS 4564 Table 3.1. The intent of this table is to understand the practical



impacts to typical natural gas compositions found in Australia. The complete calculation including assumptions and references is provided in Appendix 2.

The standard states that certain limits may be temporarily departed from under some circumstances. However the issue of such departures is not within the scope of the Standard and is subject to and provided for under relevant gas sales contracts, legislation and/or government guidelines.<sup>173</sup> The importance of AS 4564 in regulation is discussed further in Section 6. AS 4564 Table 3.1 is intended to be read in conjunction with the complimentary notes in AS 4564, and does not include any allowance for excursions, which are as provided for under gas sales agreements, state regulations or guidelines. The specification is not intended to infringe on the operating requirements of transmission and distribution companies during emergencies. It is the responsibility of the network owners and operators as well as AEMO to control the composition.

Note that table 15 indicates that the typical gas blend used as a representation for the Northern Territory will be below the Wobbe index for a 10% hydrogen blend. This is a specific issue confined to this state, as the Amadeus Gas Pipeline is not required to comply with AS 4564. This pipeline has separate gas specification limits, with a Wobbe Index range of 44.0 – 51.0 MJ/sm<sup>3</sup> and a Higher Heating Value range of 33.0 – 42.0 MJ/sm<sup>3</sup>. The minimum limit of both characteristics allowed in the Amadeus Gas Pipeline are already below the limits allowed under AS 4564, primarily due to the high nitrogen content of gas from the Amadeus Basin. The installation of Jemena's Northern Gas Pipeline, included nitrogen removal facilities at the processing plant at the inlet of the pipeline specifically to address this issue in order to meet the limits to supply the East Coast gas markets. The addition of hydrogen further lowers the Wobbe Index and Higher Heating value, and is a potential barrier to injection of hydrogen for the Alice Springs distribution network and potentially the Darwin network (noting that the current flow direction of the AGP indicates that gas to Darwin will likely be

from the Bonaparte basin). These limits may require review if hydrogen injection is considered in the NT, or nitrogen removal facilities considered where gas is sourced from the Amadeus basin. Shale gas reserves in the Beetaloo Basin are not expected to have any high nitrogen content, so removal of nitrogen is of a lesser concern for potential future gas fields from this region.

### 5.2.3.3 General Purpose Users

Conventional gas appliances currently have the ability to handle gas with a Wobbe Index in the range specified in AS 4564. There is potential that current appliances are capable of handling a larger Wobbe range but this is required to be confirmed through appliance testing.

When considering modification to the characteristic limits set out in AS 4564; consideration must be given to existing legacy appliances and their appliance certification. Depending on the test gas that was used during the appliance certification process the appliance may not be certified for the updated limits.

---

<sup>173</sup> This statement is expected to be removed in the 2019/2020 revision of AS 4564.



Table 15 AS 4564 Comparison Summary

Characteristics		Wobbe Index	Higher Heating Value	Total O <sub>2</sub>	Hydrogen Sulphide	Total Inerts	Odorised gas	Water	Dew Point	Higher Heating Value*	Relative Density†
Type	Range	Max	Max	Max	Max	Max	Max	Max		Range	Range
Units	MJ/m <sup>3</sup>	MJ/m <sup>3</sup>	mole %	mole %	mole %	mg/m <sup>3</sup>	mg/m <sup>3</sup>	°C		MJ/m <sup>3</sup>	kg/kg
Range	46.0 - 52.0	42.3	0.2	5.7	7	50	112	2		37 - 42	0.55 - 0.70
WA	100% NG	47.7	36.64	OK	OK	OK	OK	OK	OK	36.64	0.59
	90% NG + 10 % H <sub>2</sub>	46.6	34.19	OK	OK	OK	OK	OK	OK	34.19	0.54
VIC	100% NG	50.42	38.61	OK	OK	OK	OK	OK	OK	38.61	0.59
	90% NG + 10 % H <sub>2</sub>	49.17	35.96	OK	OK	OK	OK	OK	OK	35.96	0.54
NSW	100% NG	49.72	37.78	OK	OK	OK	OK	OK	OK	37.78	0.58
	90% NG + 10 % H <sub>2</sub>	48.52	35.21	OK	OK	OK	OK	OK	OK	35.21	0.53
TAS	100% NG	50.42	38.61	OK	OK	OK	OK	OK	OK	38.61	0.59
	90% NG + 10 % H <sub>2</sub>	49.2	36.01	OK	OK	OK	OK	OK	OK	36.01	0.54
QLD	100% NG	49.64	37.17	OK	OK	OK	OK	OK	OK	37.17	0.56
	90% NG + 10 % H <sub>2</sub>	48.47	34.66	OK	OK	OK	OK	OK	OK	34.66	0.51
SA	100% NG	49.72	37.78	OK	OK	OK	OK	OK	OK	37.78	0.58
	90% NG + 10 % H <sub>2</sub>	48.52	35.21	OK	OK	OK	OK	OK	OK	35.21	0.53
NT	100% NG	44.85	35.48	OK	OK	OK	OK	OK	OK	35.48	0.63
	90% NG + 10 % H <sub>2</sub>	43.89	33.14	OK	OK	OK	OK	OK	OK	33.14	0.57
ACT	100% NG	49.72	37.78	OK	OK	OK	OK	OK	OK	37.78	0.58
	90% NG + 10 % H <sub>2</sub>	48.52	35.21	OK	OK	OK	OK	OK	OK	35.21	0.53

- Within the boundaries of AS 4564
- Outside the boundaries of AS 4564
- Outside the informative range given in AS 4564

\* AS 4564 gives a guideline range for HHV of 37 - 42 MJ/m<sup>3</sup>. The values for each of the 10% hydrogen blends are all outside this informative limit. This does not mean non-compliance with AS 4564.

† It is expected that relative density values would be in the range of 0.55 to 0.70. This is not a mandatory limit.

#### 5.2.3.4 Industrial Users

AS 4564 is not intended to apply (but for in some contractual terms 'may' have been applied) to gas supplies where no general purpose users are connected to the supply system, for example a dedicated supply to an industrial user. Users who have specific needs that are outside the characteristics provided in the standard are able to nominate particular commercial contracts with a supplier. However in most instances it is expected that AS 4564 will form the basis for supply contract conditions in terms of compositional limits for industrial users connected to the distribution network.

If the addition of hydrogen was to push the natural gas out of specification for use in industrial application, where the industrial supplier has a separate supply contract with the gas production company, there would be nothing in AS 4564 to prevent the industrial user and gas Production Company from negotiating a new contract for the hydrogen blend gas. This would rely on the plant and equipment being technically suitable for the new hydrogen blend.

If the Wobbe Index is too low, flame abnormality, such as lift may occur. A high Wobbe Index may give rise to unacceptable levels of carbon monoxide. Natural gas is commonly used for heating in industrial applications. The drop in higher heating value with a 10% blend will lower the heat output of burner system; this may require burner adjustment if a small reduction in heat output is not tolerable for the application.

Industrial and large commercial appliances are individually adjusted to the available gas for optimum performance and require regular checking and adjustment.

#### 5.2.4 Recommendations for AS 4564

For the reviewed typical Australian gas composition with 10% hydrogen the current limits in AS 4564 can generally be considered acceptable, except for the Northern Territory, but there are minor revisions required to reduce ambiguity.

There are informative limits set out in AS 4564 which are used for contracts purposes. When a 10% hydrogen blend is added to natural gas the maximum higher heating value decreases. For all tested compositions the new higher heating value is lower than the 37.0 MJ/m<sup>3</sup> set out in the standard. Higher heating value may be used in contracts for valuing gas. Review of existing standards and the method for calculating the value of the gas should be completed for existing contracts.

AS 4564 is called up in regulation and commercial contracts to define the limits of the physical characteristics and components of natural gas. AS 4564 does not allow for concentrations of hydrogen given the definition of natural gas excludes it. This is also the case in some state regulations.

Addition of 10% hydrogen in the natural gas blend to the typical composition, for all states, results in HHV and relative density falling below the lower limit expectations set out in AS 4564 note 5 and 6 of Table 3.1 AS 4564. Although these are informative limits as hydrogen was not considered when this standard was developed, further investigation into the impact of lowering the expected lower limits for the HHV and relative density are required.

*It is recommended that the standard be revised with the following in mind:*

- *Definition and intended application of natural gas reviewed and updated;*
- *Expected Range of HHV found in Table 3.1 note 5 reviewed and updated; and*
- *Expected Range of relative density found in Table 3.1 note 6 reviewed and updated.*

*This recommendation is required to remove any ambiguity and uncertainty currently around gas composition in AS 4564. Elements of this action could commence immediately as the standard is currently undergoing a revision. It is expected that the recommendation will be driven by the standards committee but will require support from industry and results from current research.*

The AS 4564 standards committee is responsible for implementing the recommendations. In 2019, AS 4564 is undergoing its first revision since 2011. The current draft scope has excluded any update to consider hydrogen and it is recommended this be reviewed given the current government initiatives. Before any modifications to the standard can be completed the full extent of the technical, commercial and regulatory impacts of the changes necessary to include 10% hydrogen must be understood, including impacts to downstream installations and appliances. Ultimately, it may be sensible to align AS 4564 with AS 4645 (up to 15% hydrogen) providing all of the necessary work to assess safety, technical, commercial and regulatory impacts has been completed of the network, to confirm there are no increased risks.

It should be noted there is a global initiative and much of the work required to confirm suitability is being completed domestically or globally. FFCRC are completing appliance testing which is outlined in section 3.3.1; results of this should be leveraged where possible. Research has been completed internationally for similar projects which can be used for reference, but care must be taken as this research may not be

fully applicable.<sup>174</sup> Additionally, experiences in other countries, and especially in the European Union (EU), indicate that modern gas appliances in the majority of the EU can safely accept gases with a WI range of between 47.0 MJ/m<sup>3</sup> to 54.0 MJ/m<sup>3</sup>.<sup>175</sup> The test pressure for the EU appliances (except Netherland) is 20 mbar and the WI of the test gas is 45.66 MJ/m<sup>3</sup> to 54.76 MJ/m<sup>3</sup>. These testing parameters vary from those testing parameters used in Australia. Therefore, the proposed European WI range can only be taken as a guide when compared with Australian test conditions. The proposed high WI safety margin for European appliances is around 1.5%.<sup>176</sup>

For hydrogen blends greater than 10%, it is expected that the blend will not comply with the limits set out in AS 4564. It is possible that amendments or updates could be made to the limits set out in the standard.

### **5.3 AS 2885 – Pipelines – Gas and Liquid Petroleum**

AS 2885 applies to the design, construction and operation of steel pipelines operating above 1,050 kPag and associated piping and components that are used to transmit single-phase and multi-phase hydrocarbon fluids. These hydrocarbon fluids include natural and manufactured gas, liquefied petroleum gas, natural gasoline, crude oil, natural gas liquids and liquid petroleum products.

According to the distribution pipeline code AS/NZS 4645.1 Clause 1.2 (b), AS 2885 will also be used for any pipeline that has an operating hoop stress greater than 20% of the material's specified minimum yield stress.

AS 2885 is used throughout Australia for natural gas transmission pipelines and for some pipelines in the distribution network. It is mandated in most jurisdictions via a range of legislative instruments. In New South Wales, for instance, it is mandated under

---

<sup>174</sup> For example the appliance in the UK are bench tested at 2 kPa whereas in Australia it is 1 kPa

<sup>175</sup> Gas Appliances Directive 90/396/CEE or "GAD"

<sup>176</sup> (Economic Regulations Authority: Western Australia, 2007)

the *Pipelines regulations (2013)*. In South Australia it is mandated under the *Petroleum and Geothermal Energy Regulations (2013)*. In the Northern Territory, however, design may be to an alternative standard according to the *Energy pipelines regulations (2001)*, but it is typically a license condition to design to AS 2885. Consequently, there is general uniformity across Australia that gas pipelines operating above 1,050 kPag comply with AS 2885.

### 5.3.1 Impacts of hydrogen to pipeline design

The most significant consequence of the use of hydrogen, setting it apart from other gases, is a loss of toughness<sup>177</sup> in steel which results from adsorption of hydrogen. This is called hydrogen embrittlement (note that it should not be confused with “hydrogen attack”, which is a high-temperature effect that will not be relevant to pipelines). Corresponding to the loss of net material toughness is a reduction in fatigue life.<sup>178</sup>

Limited research is currently available into hydrogen embrittlement for high strength pipeline steels. What research is available has consistently shown that the loss of toughness corresponds to the pressure of the hydrogen. The toughness decreases as the pressure increases, up to a point, after which the effect plateaus.<sup>179</sup> This is consistent with the hypothesis that the *concentration* of the hydrogen in the steel is the critical factor.

The effect of hydrogen in a gas mixture can be different to pure hydrogen. It appears that some gases inhibit embrittlement, such as O<sub>2</sub> and SO<sub>2</sub>; others appear to be accelerators, such as CO<sub>2</sub> and H<sub>2</sub>S. Methane (CH<sub>4</sub>) and nitrogen (N<sub>2</sub>) the gases relevant to this report, appear to have no effect. Because there are no interaction

---

177 Material “toughness” is the ability of the material to tolerate defects, like cracks, without bursting.

178 A material’s “fatigue life” is its ability to tolerate repeated load cycles. Failure occurs because cracks in the material grow by small increments under each cycle; hence this property is related to toughness.

179 The pressure at which the embrittlement effect plateaus depends on the material; typical values are in the order of 2 to 20 MPa.

effects applying, the embrittlement effect of hydrogen in a methane/nitrogen mixture, is likely to be simply related to the *partial* pressure of the hydrogen, which is the total gas pressure multiplied by the mole-fraction of hydrogen in the mixture; the partial pressure should be a good proxy for the concentration of hydrogen in the steel.

A typical scenario relevant to this report is a 10% hydrogen mixture at 1,050 kPag. In such a mixture, the hydrogen has a partial pressure of about 100 kPag. Available evidence suggests that the effect of embrittlement will not be noticeable at this pressure.

Other general observations from research are that embrittlement has a greater effect on high-strength steel grades compared to low-strength grades. However, although the general embrittlement effect is less for low-strength steels, the influence on fatigue life is not necessarily reduced. It has also been demonstrated that stainless steels are *less* susceptible than carbon steels – this is likely to be due to the hard oxide layer that stainless steels have (which is what provides their protection from corrosion); this layer decreases the diffusion rate into the steel.<sup>180</sup> It is also possible that the welds on a pipeline will be affected to a greater extent than the pipe body steel.

It should be noted also that hydrogen acts to *reduce* the toughness of steel. This does not mean that the steel becomes entirely brittle and unsafe for use. The steel may remain a substantially ductile and tough material.

### 5.3.2 Current Hydrogen Pipeline Design Methodology

The American hydrogen pipeline standard, ASME B31.12, includes a concise summary of the effects of hydrogen on steel properties, and the consequences for pipeline design. Currently, the most common approach to accommodate the loss of steel toughness is to use a low “design factor” for the pipeline, that is, to limit the stress in the pipe material.

---

180 Aluminium alloys also have an oxide layer and exhibit good resistance to hydrogen embrittlement effects.

ASME B31.12 provides two design pathways – the first is to use a low design factor, the second is to do specific testing of hydrogen embrittlement effect on the material. The second approach requires the ability to conduct tensile testing of steel in a hydrogen environment; the authors of this report have not identified any Australian laboratories yet capable of conducting such experiments, though there is potential to develop such capability under the FFCRC.

Note that low design factors are an important feature of the Australian distribution piping code, AS/NZS 4645, which limits material stress to 20% of the specified minimum yield strength (SMYS), compared to the maximum of 80% permitted under AS 2885.

For comparatively low pressure and small-diameter pipelines, using a low design factor may be a very practical approach. Control of embrittlement may not require a design factor as low as 20%. For low strength materials, ASME B31.12 will permit up to 40% of SMYS without any consideration of fracture properties (Clause PL-3.7 (b)), and it permits a standard design approach without analysis for up to 50% of SMYS except in the most safety-critical location classes.

The cost implications for a low design factor become significant for new pipelines operating at high pressures, with large diameters or traversing long distances. For existing pipelines, reducing the design factor requires decreasing the maximum allowable operating pressure, which may curtail the pipeline's capacity even further than already occurs with the replacement of methane with hydrogen. Hence, for long transmission mains, this conservatism will be increasingly expensive and it would become more practical to do specific testing of material properties and increase the design factor.

For existing pipelines, AS2885 is applied in distribution networks for high pressure distribution mains and trunk mains, operated above 1050 kPa. These sections of the network are typically providing gas directly to industrial or large commercial customers, which may have some fluctuation in demand. In most cases where AS2885 is used as the design code within the context of distribution networks, the location classification is

for residential or high density, based on the proximity of residential dwellings. Pipelines designed for these location classes typically operate at or below 30% of SMYS to achieve the 'no rupture' provisions required by the location classification. Pipelines designed under AS2885 in distribution service are also typically constructed of grade X52 and lower, compared to pipelines in transmission service. The lower design factor, lower pressure and relatively low strength reduces the risk of hydrogen embrittlement compared to typical transmission pipelines. However these high pressure sections of the distribution mains will need to be assessed on a case-by-case basis to verify the material in use, design factor and operating pressure profile due to fluctuation in demand, do not result in a risk of hydrogen embrittlement if considered for hydrogen service.

### **5.3.3 Specific considerations for hydrogen**

In general, the principles of AS 2885 may be applied to steel pipelines carrying hydrogen and hydrogen mixtures without modification. Following is a list of considerations that will apply to hydrogen mixtures which will require some deviation, or supplementary considerations, to what is currently in the standard.

1. Post-hydro testing change in toughness
2. Critical defect length calculation
3. Resistance to penetration calculation
4. Propagating fracture control
5. Radiation contour calculation
6. Welding on in-service pipelines
7. Pipe fatigue from pressure
8. Pipe fatigue in stress analysis

#### **5.3.3.1 Post-hydrotesting change in toughness – AS 2885.5**

Under AS 2885.5, new pipelines are subject to a hydrostatic pressure test. The test is at a pressure 25% higher than the maximum operating pressure, and lasts for at least 2 hours. If the pipeline does not rupture during the test, then the test has proven that any post-construction defects in the pipeline are not critical at

the test pressure, and consequently they will be sub-critical at the operating pressure with a margin of safety of 25%.

This methodology assumes that the pipe has the same toughness during operation and during the test. If the toughness of the pipe decreases after the test, then the defects in the pipeline could become supercritical again.<sup>181</sup> Hydrogen embrittlement is problematic for this approach, because it may cause the toughness of the steel to decrease post-hydrotest.

In order to meet the intent of AS 2885 for pressure testing, there are a few options that may be pursued:

- **Use of a low design factor.** If the stress in a material is sufficiently low, then there will be inadequate energy to drive a fracture, even if the toughness is greatly reduced. 40 % of SMYS is commonly taken as a threshold for this, and that has been applied in ASME B31.12, though the authors of this report are not aware of specific analysis justifying this in the context of hydrogen embrittlement.
- **Modification of the test pressure factor.** Designers may ensure the test pressure factor provides sufficient margin of safety to accommodate embrittlement effects. At low partial pressures, where the embrittlement is minor, analysis and experimentation may confirm that 25% test pressure factor is still adequate to function as a proof test. At higher pressures, adjustment of the test factor may be possible.
- **Increased rigour in preventing and detecting defects.** Currently under AS 2885, it is permissible to do some welding after hydrotest. These “tie-in” or “golden” welds have not been subject to a proof test when they are put into operation. Instead, they are subject to increased inspection requirements to ensure there are no critical defects in the weld.

---

181 The only means of embrittlement that is accommodated by the standard is “low temperature embrittlement”. This is prevented by ensuring that the pipeline operates above the temperature at which it would transition to low-toughness behaviour (the ductile-brittle transition temperature).

This philosophy could be applied more broadly if post-hydrotest embrittlement is a concern, however it relies on a thorough understanding of hydrogen embrittlement it's interaction with defects.

### 5.3.3.2 Critical defect length calculation

The critical defect length (CDL) of a pipeline is calculated using the methodology in AS 2885.1 Clause 5.5.4. The critical defect length is a function of material toughness, and consequently will be reduced due to hydrogen embrittlement.

The standard applies *mandatory* limits on the critical defect length only in high-consequence areas—that is, locations which are designed to location classes T1 or T2 under the standard. Usually the reason for this designation is that the location has a significant population density such that a pipeline rupture would be very hazardous to the general public. In these locations, the CDL is required to be at least 1.5 times as long as the largest defect that may be created by a credible external interference threat to the pipeline.

For example, a pipeline may pass through a residential area where a large number of people and dwellings would be affected by a pipeline incident. Suppose that in this location, the typical activities in the area are analysed and it is determined that a thirty-five tonne excavator may be used. Analysis shows that such an excavator could put a hole in the pipe that is 80mm long. In that location, the critical defect length would be required to be at least 120mm (80 x 1.5).

In other locations, the safety management of the pipeline takes the critical defect length into account in working out the consequence of an external interference threat, but there are no mandatory requirements to be met.

In order to understand the effect of hydrogen embrittlement on the critical defect length calculation, the calculation should be reassessed at the reduced toughness. This calculation is unlikely to require precision; in most cases it would be reasonable to conservatively estimate the reduced toughness. This is especially true of low-pressure and low design-factor pipelines, which typically have a high CDL.



### 5.3.3.3 Resistance to penetration

Pipeline designers using AS 2885.1 also make predictions of what types and sizes of mechanical equipment (e.g. excavators, rippers, and augers) are capable of penetrating the pipeline; this is not a precise determination, but provides an indicative understanding of pipeline safety.

There is a calculation method embedded in Appendix E of AS 2885.1. This methodology represents the resistance of a pipe to penetration as a function of its ultimate tensile strength.

Experimental data predicts that the ultimate tensile strength is not reduced by the presence of hydrogen. Hence, it is not predicted that the resistance to penetration would be altered by hydrogen embrittlement. However, to the author's knowledge, this has not been confirmed experimentally.

### 5.3.3.4 Propagating fracture control

After a pipe ruptures, in some circumstances the crack in the pipe can grow along the pipeline indefinitely. This can only occur when the fracture travels faster than the decompression wave in the fluid. The fracture velocity is a function of the dynamic material toughness, the decompression velocity is a function of the composition of the gas, and the presence of hydrogen may have an impact on both.

The gas decompression velocity is likely to increase with hydrogen (at atmospheric pressure, the speed of sound in pure hydrogen is four times greater than in air). AS 2885.1 generally recommends the use of the software package EPDECOM, developed by the Energy Pipeline Cooperative Research Centre (EPCRC) at the University of Wollongong, to analyse the decompression wave speed and to predict the minimum ductile toughness required to arrest fracture. This software uses GERG equations of state. It is able to accommodate hydrogen as an input; however, the FFCRC are undertaking a project to conduct decompression testing on hydrogen and hydrogen mixtures to test this equation of state; its accuracy at atypical hydrogen levels is questionable due to limited experimental data.

The fracture velocity is controlled under AS 2885.1 Clause 5.3 in two ways. Firstly, the fracture mode is kept ductile, by ensuring that the fracture surface from drop-weight-tear testing is at least 85% ductile at operating temperatures—this is called brittle fracture control. Secondly, the toughness is required to be greater than the arrest toughness calculated using EPDECOM—this is called ductile fracture control.

The fracture velocity is likely to increase due to the presence of hydrogen due to the loss of toughness and increasingly brittle fracture mode. However, this has not been confirmed. Few full-scale burst tests have been conducted using hydrogen, and there are a number of possible mitigating factors that may cause the effective dynamic toughness to be greater than the static toughness exhibited in laboratory testing. This is one of the subjects that will be researched by the FFCRC.

In the meantime, the only approach available to analysts is to gain confidence that the toughness of the steel will be sufficient to arrest fracture when hydrogen embrittlement is taken into account. This means confirming the fracture mode is ductile and confirming that the toughness exceeds the minimum required toughness for fracture arrest. Obtaining data on hydrogen-impregnated steel remains a challenge, but if this data is successfully obtained, existing methods can probably be applied effectively with a margin of safety. If the fracture mode is not substantially ductile, and the material fails by cleavage fracture, then the only available option is to ensure the **stress** in the steel is low enough that it cannot drive even a brittle fracture.

Again, for pipelines that have a low design factor and low internal pressure, this should be achievable. As an example, the toughness demand for fracture arrest is currently considered low enough to be neglected entirely when the stress is below 40% of SMYS – refer AS 2885.1 Clause 5.3.4.3; however, this clause is applied to materials that meet the prior clauses requiring minimum 27 J toughness and brittle fracture control, and so this exemption should not be used if they are not also met.

An alternative means of controlling propagating fracture is to use crack arrestors. These are sections of the pipe installed at intervals which will arrest a crack. Generally they consist of thicker sections of pipe that are operating at very low stress.

### 5.3.3.5 Radiation contour calculation

Safety management of pipelines, per AS 2885.6, requires an understanding of the maximum extent of the harmful radiant heat that would be present if the pipeline had an ignited leak. The size of the consequence zone for various size leaks can be calculated using AS 2885.6 Appendix B.

While the methodology of this appendix is generally applicable, the data in the appendix may not be. The assumption made in developing the full-bore rupture graphs was that the specific energy was 39.5 MJ/Sm<sup>3</sup> (the density is unfortunately not stated)—the parameters of the underlying calculation will not likely be true of a hydrogen mixture.

With only up to 10% hydrogen in the gas, the radiation contours likely have *sufficient* accuracy for the safety management process to be effective. However, release rate modelling could be conducted to gain more accurate values and confirm the range of useful validity of the data.

The radiation contour modelling in Section 4.4.6 of this report show minimal difference for a 10% blend between the AS 2885 method and modelling software.

### 5.3.3.6 Welding on in-service pipelines

AS 2885.2 defines welding requirements for pipelines. Section 16 relates to welding on pipelines while they are operating. The flowing gas inside the pipeline strips heat away from the weld, which can make it difficult to achieve the pre-heat conditions required. The methodology currently used to get around this is to do the weld qualification on a pipe with flowing gas inside it, and confirm that the weld procedure is suitable.

In-service welding on a hydrogen pipeline may be exposed to risks that are not present with other pipelines. Hydrogen attack is an effect similar to

corrosion that can occur at high temperatures, which could damage the pipeline steel. Also, the hydrogen adsorbed while the steel is hot can cause hydrogen assisted cracking (HAC) when it cools down. Significant effort is taken to avoid HAC in existing welding methodologies; the presence of hydrogen inside the pipeline could invalidate those efforts.

Until specific work is done to understand the conditions under which in-service welding on a hydrogen-containing pipeline may be safely undertaken, the practice should be entirely avoided.

### 5.3.3.7 Pipeline fatigue from pressure

Pipeline fatigue can occur from pressure cycling. Traditionally, fatigue is not a significant consideration for gas pipelines due to the compressibility of the gas, which reduces the rate and hence frequency at which the pressure can change compared to a liquid pipeline.

Where fatigue does require consideration is on “pack-and-deplete”<sup>182</sup> pipelines, especially those with high design factors. These are exposed to greater pressure cycling and hence are at greater risk of a fatigue failure.

Currently fatigue is covered in Appendix J of AS 2885.1. The appendix provides a screening method based on crack growth modelling (taken from IGE/TD/1). (The underlying modelling is not strictly accurate for a pipeline that has been pressure tested to Australian requirements, but is adequate for a screening study for typical pipelines.)

As described above, hydrogen has an effect on fatigue life. Just as with the previous items, fatigue is unlikely to be a concern for low design-factor pipelines operated in a traditional manner; that is, with a fairly steady pressure profile. Most distribution systems are still operated in this way.

---

<sup>182</sup> “Pack and deplete” pipelines are not operated at steady conditions, but rather cyclic conditions, where the inventory (“line-pack”) in the pipeline is allowed to accumulate and then is drawn down, resulting in large pressure cycles. Such pipelines are traditionally used as gas inventory for batch processes in an industrial setting, for peaking power stations and similar uses.

If any hydrogen-mixture pipelines are intended to be operated using a pack-and-deplete strategy, however, then the fatigue-life will require specific attention, and Appendix J of AS 2885.1 should not be considered applicable.

### 5.3.3.8 Fatigue in stress analysis

Fatigue is also taken into consideration in pipeline stress analysis to AS 2885.1 Clause 5.7. This methodology uses a cycling factor to limit the stress amplitude from cycling longitudinal stresses:

$$f = 6N^{-0.2} \leq 1.2$$

This method is based on, and consistent with, ASME B31.4.

ASME B31.12, the American hydrogen pipeline code, applies the same method, but takes into account the ultimate tensile strength of the material, hence providing a lower design stress.

The following important changes in ASME B31.12 are noted:

- A value of  $f$  greater than 1 may only be used with a design stress,  $S$ , of 138 MPa or lower. The equivalent conditions applicable under the AS 2885.1 implementation of this formula could be calculated, but alternatively it is better not to apply  $f$  greater than 1 at all.
- The number of cycles,  $N$ , is multiplied by 10 for materials subject to hydrogen embrittlement.

The second of these modifications is clearly intended to accommodate the loss of fatigue life that occurs in the presence of hydrogen, and is recommended for use in AS 2885.1 also, in the absence of specific data.

### 5.3.4 Application of AS 2885

The scope of the AS(NZS) 2885 series applies predominantly for hydrocarbon and carbon dioxide fluids and has not been developed with consideration for hydrogen service. As detailed in Clause 1.2.1 of AS 2885.0:

*AS(NZS) 2885 series applies to pipeline systems that are used to transmit single-phase and multi-phase hydrocarbon fluids, such as natural and manufactured*

*gas, liquefied petroleum gas, natural gasoline, crude oil, natural gas liquids and liquid petroleum products.*

*The AS(NZS) 2885 series also provides for pipeline systems intended to transport fluids that are predominantly carbon dioxide.*

AS 2885 does allow for transport of other fluids, including non-hydrocarbon gases, under Clause 1.2.2 of AS 2885.0, but notes that the application of this requires special consideration.

Australian Standard is also a risk-based or “objective” standard. It is intended to be applied by *competent* persons (defined under the standard as a “person or organisation having an appropriate combination of knowledge, skills and experience to safely and effectively perform the task required”) who exercise “appropriate experience and engineering judgement”. It is permissible to deviate from the scope and requirements of the standard, provided that the *intent* of the standard is met. This is enunciated in Clause 1.6.2 of AS 2885.0:

*AS(NZS) 2885 series Standards are not intended to prohibit the use of any materials, designs, methods of assembly, procedures or practices (items) that do not conform with specific requirements of the AS(NZS) 2885 series, or are not mentioned in it, but do give equivalent or better results to those specified.*

*The licensee shall ensure the suitability of the item is determined against the fundamental principles of the AS(NZS) 2885 series, and any additional requirements (including technical, quality, procedural, safety, and maintenance) needed to satisfy the fundamental principles shall be developed. Prior to the item being used, it shall be approved.*

Consequently, it is not a requirement to revise AS 2885 before hydrogen can be permissibly used and as a non-hydrocarbon fluid, it is allowed under Clause 1.2.2 of AS 2885. An individual pipeline licensee can demonstrate and approve that they have met or exceeded the intent of the standard, but would need to apply appropriate consideration for hydrogen as a fluid.

### 5.3.5 Recommendation for AS/NZS 2885

The review of AS 2885 identified two recommendations; with current research expected to fill the knowledge gaps over time.

AS 2885 does not explicitly prohibit the use of 10% hydrogen in natural gas, however as a standard developed for natural gas and liquid petroleum it was not written with hydrogen in mind. AS2885 Part 0, Section 1.2.2 allows the application for pipeline systems to transport other non-hydrocarbon fluids under special circumstances.

There are some elements of the standard that require further investigation and assessment of the impacts. The current approach to hydrogen pipeline design on other jurisdictions is to use a low design factor, to ensure the stress in the pipeline wall remains low. ASME B31.12 provides a pathway for doing this, though that standard is still in relatively early development, and has limited guidance with regards to fatigue. Research would be required to begin increasing the design factor beyond current experience; this includes:

- Investigation of embrittlement at distribution operating conditions;
- Investigation of ductile fracture propagation;
- Review of impacts for in-service welding; and
- Confirming insensitivity of resistance to penetration to hydrogen embrittlement.

It is recommended that in-service welding is prohibited until investigations into the impacts of hydrogen on it have been conducted.

Hydrogen embrittlement and loss of fatigue life is expected even at relatively low hydrogen concentrations and low stress. It is recommended that work is completed to define a safe envelope for operating pressure and stress with a 10% hydrogen blend for trunk-lines and high pressure mains, within which hydrogen embrittlement effects can safely be neglected.

As described in Clause 1.6.1 of AS 2885.0, the standard is subject to continuous improvement. Appendix T of AS 2885.1 defines specific considerations for pipelines carrying pure CO<sub>2</sub>. It was introduced in the 2012 revision of the standard in response to an initiative of the Carbon Capture Taskforce of the Australian Government Department of Resources Energy and Tourism.

A similar approach could be taken to the use of Hydrogen in the context of the standard. In response to a review of the standard with respect to hydrogen, modifications to the standard could be made so that it remains a repository of Australian experience and a useful guideline for best-practice design.

The latest revision of AS 2885 was issued in December 2018. The typical review cycle for the standard is approximately five years, however a project proposal to review the standard can be raised at any time. Unless the next revision can be accelerated, an interim measure, such as a code of practice, may be required to provide guidance to the industry on the application of hydrogen under the AS 2885 series.

*It is recommended that a review of AS 2885 is undertaken with respect to the specific threats associated with hydrogen, and modifications to the standard be completed or a code of practice for hydrogen developed in the interim period before the next formal revision. It is also recommended that hydrogen is added explicitly as a fluid, similar to how carbon dioxide is included in the standard series. This is a medium term action as the higher pressure sections of the distribution networks are less likely to be targeted*

as injection points initially, and the standard currently allows for alternate fluids with special consideration. It is expected that this would be driven by the Australian standards committee in charge of this AS 2885 set of standards (ME-038) with support from research and industry.

## 5.4 AS/NZS 60079 – explosive atmospheres Series

The objective of this series is to clearly set out the requirements for the design, selection and installation of electrical equipment in hazardous areas.<sup>183</sup> These requirements are in addition to the standard requirements for the installation of electrical equipment in non-hazardous areas. The Australian standard are based on the international IEC 60079 series.

### 5.4.1 Current hazardous area methodology

AS/NZS 60079 does not explicitly apply for use with natural gas. The standard is used where an explosive gas atmosphere is present. Therefore, the standard is applicable for small concentrations of hydrogen in natural gas up to pure hydrogen.

A **hazardous area** is defined as:

***“an area in which an explosive gas atmosphere is or may be expected to be present in quantities such as to require special precautions for the construction, installation, and use of the equipment.”***

(Standards Australia - AS/NZS 60079.10.1, 2009) Clause 3.3

183 (Standards Australia - AS/NZS 60079.1, 2017)

When defining a hazardous area the gas, which is expected to be present, must be assessed and assigned a gas group. A gas group is a classification from IIA (least onerous) to IIC (most onerous) is calculated based on the Minimum Ignition Current (MIC) ratio and/or Maximum Experimental Safe Gap (MESG) of the gas.

MESG for a gas mixture can be estimated based on the Le Châtelier's relationship of the blended gas properties and gives the following formula for MESG.<sup>184</sup>

$$MESG_{\text{mix}} = \frac{1}{\sum_i \left( \frac{x_i}{MESG_i} \right)}$$

The values used as a basis for the class are taken from AS/NZS 60079.20.1:2012, Clause 4.4 and are shown below. These values define the ranges where either MIC or MESG may be used independently to determine gas group.

Group IIA:	MIC > 0.9	MESG > 0.9 mm
Group IIB:	0.5 ≤ MIC ≤ 0.8	0.55 mm ≤ MESG ≤ 0.9 mm
Group IIC:	MIC < 0.5	MESG < 0.55 mm

Consideration of both MIC and MESG is required when:

Group IIA:	0.8 ≤ MIC ≤ 0.9	Need to confirm by MESG
Group IIB:	0.45 ≤ MIC ≤ 0.5	Need to confirm by MESG
Group IIC:	0.5 ≤ MESG ≤ 0.55	Need to confirm by MIC

184 (Standards Australia - AS/NZS 60079.20.1, 2009) Clause 4.6



An accurate method for the estimation of MIC has not been provided in AS/NZS 60079.20.1:2012 resulting in the consideration only of MESH for an estimate of gas group determination. For natural gas containing any concentration of hydrogen, additional testing will be required to determine MIC.

## 5.4.2 Considerations for hydrogen

In addition to Gas Group, gases are also assessed based on a Maximum Permissible Surface Temperature, a classification from T1 (highest temperature) to T6 (lowest temperature) which is based on the auto-ignition temperature of gasses. Hydrogen has a high auto-ignition temperature (560 °C) resulting in no change from T1 (highest temperature) classification.

### 5.4.2.1 Changes in Hazardous Area Classification

Table 16 (right) gives the result for hydrogen-methane blend from 0% to 100% hydrogen. Natural gas blends have additional components, both flammable and inert, which will affect these results.

Table 17 (right) also shows the indicative gas group changes with the addition of 10% hydrogen for each state's typical gas.

These results show that on the basis of this assessment, a blend of 10% hydrogen is likely to be classed as an IIB gas group.

The consequence of changing the gas group from IIA to IIB is not considered to be significant. In GPA's experience most hazardous are certified electrical equipment rated equipment installed for IIA service in Australia is actually rated to a minimum of IIB. The most significant change expected will be the updates to a facility's hazardous area documentation to incorporate the changes to gas group and composition if applicable.

It should further be noted the AS/NZS 60079 series of standards is generally only applied upstream of distribution network consumer connections or for large industrial installations connected to the distribution

network. The standard has not been widely applied to domestic or small scale commercial installations as these are generally excluded in the scope of the standard.

**Table 16**

*Hazardous Area Classification – hydrogen-methane*

H2 Conc. %	MESH mm	Gas Group	Temperature Class
0	1.12	IIA	T2
10	0.87	IIB	T2
20	0.71	IIB	T2
30	0.60	IIB	T2
40	0.52	IIB	T2
50	0.46	IIC	T2
60	0.41	IIC	T2
70	0.37	IIC	T2
80	0.34	IIC	T2
90	0.31	IIC	T2
100	0.29	IIC	T2

**Table 17**

*Hazardous Area Classification – Blend Specific Results*

Blend	MESH mm	Gas Group	Temperature Class
SA/NSW Moomba 0%	1.13	IIA	T2
SA/NSW Moomba 10%	0.88	IIB	T2
QLD Gladstone 0%	1.14	IIA	T2
QLD Gladstone 10%	0.88	IIB	T2
VIC/TAS Longford 0%	1.12	IIA	T2
VIC/TAS Longford 10%	0.87	IIB	T2
WA WLPG 0%	1.17	IIA	T2
WA WLPG 10%	0.90	IIB	T2
NT Typical 0%	1.23	IIA	T2
NT Typical 10%	0.93	IIA	T2



### **5.4.3 Areas for development and further research**

This assessment for MIC ratio and MESG is based on the methodology for outlined in the standard. It is recommended that gas testing should be undertaken to confirm these theoretical values are accurate for a 10% hydrogen blend in natural gas.

It should be noted that AS60079.20.1:2012, Clause 5.2.4 states that blends of industrial methane (natural gas) with up to 25% (V/V) of hydrogen may be classified as class IIA. This study has not determined results to support this clause.

### **5.4.4 Recommendations for AS 60079**

The results from the calculation completed for typical natural gas compositions found in Australia suggest hazardous area zone for a natural gas with 10% hydrogen concentration should be IIB as opposed to IIA.

AS 60079.20.1:2012, Clause 5.2.4 states that blends of industrial methane (natural gas) with up to 25% (V/V) of hydrogen may be classified as class IIA. The assessment for MESG completed in this report is based on the methodology outlined in AS 60079.

*It is recommended that a literature review be completed to identify whether research or testing has previously been completed to confirm MESG. This recommendation is required to ensure that hazard area gas zones remain the same for up to 10% hydrogen. This action is a medium term action as pilot facilities are currently assessing on a case-by-case basis but would be required before hydrogen utilisation in the distribution networks increases. It is expected that this recommendation will be driven by industry with support from research.*

## 5.5 Summary of Implications for Australian Standards

Table 18 gives a summary of the implications that 10% hydrogen by has on the Australian Standards.

**Table 18** Summary of Implications to Australian Standards

Standard	Implications and considerations
AS/NZS 4645 Series	<p>A high level review of the AS/NZS 4645 series was completed as part of this review assessing the implications of addition of 10% hydrogen to natural gas in the distribution network.</p> <p>While the standard prescribes an upper limit of 15% hydrogen (by volume) which exceeds the 10% investigated in this study it is understood that a thorough review of the standard was not completed which assessed the impacts of hydrogen in general.</p> <p>The standard references AS 4564 directly for a gas quality rather specifying a gas quality, so no gas quality implications.</p> <p>In general, due to the low stress (&lt;20% SMYS) and pressure (&lt;1050 kPa) allowed under the standard the materials listed are generally accepted as suitable for a 10% blend, or higher, based on the existing research and studies in this area.</p> <p>From a safety and risk perspective the standard is generally not prescriptive. The impacts of 10% hydrogen in natural gas are similar to that of pure natural gas.</p> <p>It is suggested that a review and update of AS/NZS 4645 series of standards be completed to identify and gaps in knowledge. It is expected that only minor issues will be found.</p>
AS 4564	<p>A high level review of AS 4564 was completed. The addition of 10% hydrogen to a typical natural gas blend changed the gas quality parameters. While most remained acceptable the HHV value and SG fell below the informative limits set out in the standard.</p> <p>AS 4564 is for general purpose natural gas and does not allow a blend.</p> <p>Existing informative minimum limits in the code with be breached for Higher Heating Value and Relative Air Density at 10% blends.</p> <p>It is recommended that the standard be revised with the following in mind:</p> <ul style="list-style-type: none"> <li>Definition and intended application of 'natural gas' reviewed and updated;</li> <li>Expected Range of HHV found in Table 3.1 note 5 reviewed and updated; and</li> <li>Expected Range of relative density found in Table 3.1 note 6 reviewed and updated.</li> </ul> <p>The issues identified are considered minor and should are not considered a barrier to injecting 10% hydrogen in the natural gas distribution network.</p>

Table 18 continued

Standard	Implications and considerations
AS 2885 Series	<p>AS 2885 was reviewed as part of this review as it is used in distribution networks where the operating pressure exceeds 1,050 kPa.</p> <p>While AS 2885 does not explicitly prohibit the use of 10% hydrogen in natural gas, it requires special consideration for non-hydrocarbon gases such as hydrogen.</p> <p>An individual pipeline licensee can demonstrate and approve that they have met or exceeded the intent of the standard.</p> <p>There are elements of the standard where further investigation and research is required to assess the impact of hydrogen, particularly around fracture and fatigue.</p> <p>It is not a requirement to revise AS 2885 before hydrogen can be permissibly used and should not be seen as a barrier to allowing injection of up to 10% hydrogen into the natural gas network. However high pressure sections of the distribution mains designed under AS2885 will require assessment on a case-by-case basis to verify the material in use, design factor and operating pressure profile due to fluctuation in demand, do not result in a risk of hydrogen embrittlement if considered for hydrogen service.</p> <p>Revising AS2885 to include hydrogen in the scope of the standard will reduce the burden on individual projects to document how the threats associated with hydrogen are managed, and support the regulatory approval process.</p>
AS/NZS 60079 Series	<p>AS/NZS 60079 was reviewed to understand the impacts to hazardous area and equipment that 10% hydrogen has. The series of standards do not explicitly apply for use with natural gas. The standard is used where an explosive gas atmosphere is present. Therefore, the standard is applicable for small concentrations of hydrogen in natural gas up to pure hydrogen.</p> <p>It was found that for 10% hydrogen in natural gas blend, using the methods outlined in AS/NZS 60079, the gas group may change to a IIB. This is inconsistent with the state that states <i>"blends of industrial methane (natural gas) with up to 25% (V/V) of hydrogen may be classified as class IIA"</i>.</p> <p>It is recommended that a literature review be completed to identify if research or testing has previously been completed on the MESH values. Again, this recommendation is not seen as a barrier to injection up to 10% hydrogen into the natural gas distribution network.</p>

# 6 IMPLICATIONS FOR AUSTRALIAN STATE REGULATIONS

A state by state review of acts and regulations covering distribution of natural gas was undertaken to understand the regulatory impacts of addition of up to 10% hydrogen into the gas distribution networks in each state. The review focused specifically on legislation concerned with the safety and technical aspects of the gas distribution networks.

The analysis outlined in the following sections builds on early work prepared by Johnson Winter and Slattery for Energy Networks Australia.<sup>185</sup>

In each section that follows, various definitions are highlighted among others, for their relevance to the subsequent discussion of barriers to and implications of introduction of up to 10% hydrogen into the gas distribution networks for the particular act or regulation under review.

While national gas market regulatory framework of gas networks was outside the scope of this review, a review of the regulatory framework concerned with market entry, supply and retail provisions under the National Gas Law was contributed by South Australian Government. See section 6.10 for details of this review.

## 6.1 Australian Capital Territory

The acts and regulations that govern safety and technical aspects of gas distribution networks in the Australian Capital Territory are:

- Utilities Act 2000 (ACT)
- Utilities (Technical Regulation) Act 2014 (ACT)

---

<sup>185</sup> Johnson, Winter and Slattery, *A report on the injection of hydrogen and biogas into gas distribution networks*, Energy Networks Australia, 2018.

In the Utilities Act 2000 (the Act):

- **Gas** means natural gas; and
- **Natural gas** has the same meaning as in the National Gas (ACT) Law, section 2\*
- A **gas distribution network** consists of infrastructure used, or for use, in relation to the distribution of gas by a person through a distribution pipeline for supply to premises of another person.

\*Section 2 of the National Gas Law (ACT) states:

- **natural gas** means a substance that -
  - (a) is in a gaseous state at standard temperature and pressure; and
  - (b) consists of naturally occurring hydrocarbons, or a naturally occurring mixture of hydrocarbons and non-hydrocarbons, the principal constituent of which is methane; and
  - (c) is suitable for consumption;

Under the definition of *gas* in the Act, it is uncertain whether hydrogen would be recognised in the gas distribution networks as it does not 'consist of naturally occurring hydrocarbons, or a naturally occurring mixture of hydrocarbons and non-hydrocarbons'. As such, up to 10% hydrogen in the gas distribution networks could be interpreted not be regulated by the Act and its subordinate regulations.

The definition of *gas* is not prescribed in the Utilities (Technical Regulation) Act, however it does define **gas network** as per the Utilities Act 2000. This could be interpreted to only apply to **natural gas** as well.

Consideration should be given to how best to enact legislation that regulates the production and distribution of hydrogen in the gas networks in ACT.

## 6.2 New South Wales

The acts and regulations that govern safety and technical aspects of gas distribution networks in New South Wales are:

- Gas Supply Act 1996 (NSW)
- Gas Supply (Safety and Network Management) Regulation 2013 (NSW)

### 6.2.1 Gas Supply Act 1996

The *Gas Supply Act 1996* (the Act) is an Act to regulate the supply of gas; and for other purposes.<sup>186</sup>

#### 6.2.1.1 Relevant definitions

Among others, the Act includes the following definitions for the purposes of the Act.<sup>187</sup>

- **Gas** means:
  - (a) natural gas, or
  - (b) liquefied petroleum gas, or
  - (c) any other substance that the regulations declare to be a gas for the purposes of this Act.
- **Natural gas** has the same meaning as it has in the National Gas (NSW) Law\*.
- **Liquefied petroleum gas** means a liquid of gaseous substance containing a mixture of hydrocarbons, basically consisting of butane or butane or propane or propene, or any mixture of them.

\*Under the *National Gas (NSW) Law*, natural gas means a substance that<sup>188</sup> –

- (a) Is in a gaseous state at standard temperature and pressure; and
- (b) Consists of naturally occurring hydrocarbons, or a naturally occurring mixture of hydrocarbons and non-hydrocarbons, the principal constituent of which is methane; and
- (c) Is suitable for consumption.

---

186 *Gas Supply Act 1996* (NSW).

187 *Gas Supply Act 1996* (NSW) Dictionary, p70-71.

188 National Gas (NSW) Law, s2.

Further,

- A **reticulator's authorisation** authorises its holder "to operate the distribution pipeline so specified for the purpose of conveying natural gas to other persons."<sup>189</sup>
- A **distributor's licence** authorises its holder "to operate the distribution system so specified for the purpose of conveying to other persons any gas so specified."<sup>190</sup>
- A **network operator** means a reticulator or a distributor.<sup>191</sup>

The application and implications of these definitions are discussed in the following sections.

#### 6.2.1.2 Review

The definition of *natural gas* for the purposes of the Act does not include hydrogen as it is not present as part of a naturally occurring mixture of hydrocarbons and non-hydrocarbons at standard temperature and pressure.

Part 2 of the Act is concerned specifically with natural gas. A *reticulator's authorisation* provides authorisation for operation of a distribution pipeline for the purpose of conveying *natural gas*. As such, a reticulator's authorisation would not apply to a distributor of a blend of up to 10% hydrogen in a natural gas network. Consideration would need to be given to the impact to a reticulator's authorisation of the introduction up to 10% hydrogen, as this component of the gas blend may no longer be authorised under the reticulator's authorisation.

Regulation of hydrogen in the gas networks could logically fall under Part 3 of the Act, which is concerned with liquefied petroleum gas and other gases. This could be achieved by developing a regulation that prescribes either pure hydrogen or a blend of hydrogen in natural gas as *gas*, for the purposes of the Act.

---

189 *Gas Supply Act 1996* (NSW), s6(a).

190 *Gas Supply Act 1996* (NSW), s35.

191 *Gas Supply Act 1996* (NSW), Dictionary p71.

A *distributor's licence* authorises operation of a distribution system for the purpose of conveying any gas so specified. As such, a blend of up to 10% hydrogen in the gas distribution network could be authorised under a distribution licence.

Section 34 of Part 3 prohibits unlicensed distribution of LPG and any other gas prescribed by the regulations without doing so under the authority of a distributor's licence.<sup>192</sup> Prescription of pure hydrogen or a blend of hydrogen in natural gas as *gas* by regulation under the Act would therefore also ensure that hydrogen could not be distributed *without* an appropriate licence.

## 6.2.2 Gas Supply (Safety and Network Management) Regulation 2013

The Gas Supply (Safety and Network Management) Regulation 2013 (Safety and Network Management Regulation) makes provision with respect to the following:<sup>193</sup>

- (a) the safety of gas networks;
- (b) the safety and operating plans for gas networks;
- (c) the standards for natural gas;
- (d) infrastructure protection; and
- (e) miscellaneous matters.

### 6.2.2.1 Safety

Parts 2 and 3 of the Safety and Network Management Regulation refer to *network operators*. As defined in the Act, a network operator means a reticulator or a distributor; therefore Parts 2 and 3 would be applicable to a natural gas network or any gas so specified.

Part 2 of the Safety and Network Management Regulation outlines the requirements for ensuring safe network operation. It requires that "a network operator must, when designing, constructing, operating or extending a gas network or any part of a gas network, take into account any standards (such as codes, Australian Standards, guidelines or other requirements)

---

<sup>192</sup> *Gas Supply Act 1996* (NSW), s34.

<sup>193</sup> Gas Supply (Safety and Network Management) Regulation 2013 (NSW), Parts 2 - 6.

that have been notified in writing to the network operator by the Secretary for the purposes of this subclause".<sup>194</sup>

Part 3 of the Safety and Network Management Regulation outlines the requirements for safety and operating plans, and specifies that "a network operator must not construct, alter, extend, maintain, repair or operate a gas network except in accordance with a safety and operating plan".<sup>195</sup>

The 'matters to be included in safety and operating plans' are outlined in clause 13 and Schedule 1, and include a range of matters including: gas quality standards; analysis of hazardous events and prevention measures; and operating, maintenance, reporting and emergency response procedures.<sup>196</sup>

In addition to outlining the requirements of a network operator's safety and operating plan, the Secretary can direct the amendment of a network operator's safety and operating plan, or direct a network operator to take action to comply with the requirements of a safety and operating plan or any codes, standards or specification set out or referred to in that plan.<sup>197</sup>

The effect of these clauses, combined with the ability of the Secretary to specify compliance with any codes, standards or procedures deemed necessary is that the regulator can require adequate consideration of the impacts of the addition of up to 10% hydrogen into the gas networks through compliance with the network operator's safety and operating plan.<sup>198</sup>

---

<sup>194</sup> Gas Supply (Safety and Network Management) Regulation 2013 (NSW), c6(2).

<sup>195</sup> Gas Supply (Safety and Network Management) Regulation 2013 (NSW), c11(4)(a) – see section for full context.

<sup>196</sup> Gas Supply (Safety and Network Management) Regulation 2013 (NSW), c13, and Schedule 1.

<sup>197</sup> Gas Supply (Safety and Network Management) Regulation 2013 (NSW), c19 and 20.

<sup>198</sup> Or, more broadly, by notification in writing by the Secretary as outlined in Gas Supply (Safety and Network Management) Regulation 2013 (NSW) Part 2, c6(2).



### 6.2.2.2 Quality

Part 4 of the Safety and Network Management Regulation deals with natural gas standards, and includes requirements relating to testing, compliance, exemptions and natural gas odour. In Part 4, clause 22 includes the following definitions:

- **Compliant natural gas** means natural gas that complies with the standards set out in AS 4564 – 2011.
- **Non-compliant natural gas** means natural gas that is not compliant natural gas.
- **Reticulator** means and authorised reticulator.

As outlined in section 5.2 of this report, the quality specification provided by AS 4564 defines the requirements for providing a natural gas suitable for transportation in distribution systems and safe for general purpose use, and provides the range of gas properties consistent with safe operation of the natural gas appliance population.<sup>199</sup>

As discussed in relation to the Act, the above definitions would not apply to addition of up to 10% hydrogen into natural gas; therefore Part 4 of the Safety and Network Management Regulation does not directly apply to hydrogen.

The Safety and Network Management Regulation is silent on quality standards for LPG or other gas.

Ensuring appropriate quality standards for a blend of up to 10% hydrogen in the gas networks could be achieved by the application of Part 2, section 6(2) of the

---

199 Standards Australia, *AS 4564 – Specification for General Purpose Natural Gas*, s1.1, 2011.

Safety and Network Management Regulation, which states:

*“A network operator must, when designing, constructing, operating or extending a gas network or any part of a gas network, take into account any standards (such as codes, Australian Standards, guidelines or other requirements) that have been notified in writing to the network operator by the Secretary for the purposes of this subclause.”<sup>200</sup>*

In order to specify quality requirements for up to 10% hydrogen in the gas networks, the Secretary could specify compliance with ‘other requirements’ detailed by the Secretary, such as the quality specifications (i.e. Table 3.1 – Specification Limits) outlined in AS 4564,<sup>201</sup> so that the same quality standards would apply to a natural gas distribution network as to a blend of up to 10% hydrogen in the network.

As discussed in section 5.2 the introduction of up to 10% hydrogen into the NSW gas distribution networks is unlikely to exceed the gas quality specifications identified in AS 4564, however utilisation of the above clause would ensure that the network operator must still take steps to demonstrate compliance with the ‘other requirements’ detailed for this purpose by the Secretary.

### 6.2.2.3 Odour

Clause 30 of Part 4 requires that natural gas must have a “distinctive and unpleasant odour that is discernible at a level specified in the reticulator’s safety and operating plan”.<sup>202</sup> Whilst the requirements of Part 4 would not apply to hydrogen (not being natural gas), the requirement to ensure an appropriate level of odorant for a blend of up to 10% hydrogen in the gas networks could be specified by the Secretary in the requirements for the safety and operating plan, as discussed in relation to specification of gas quality standards above.

---

200 Gas Supply (Safety and Network Management) Regulation 2013 (NSW), c6(2).

201 Standards Australia, *AS 4564 – Specification for General Purpose Natural Gas*, s3.1, 2011.

202 Gas Supply (Safety and Network Management) Regulation 2013 (NSW), c30.

As outlined in section 4.4.7, there are no known chemical incompatibility issues of note between hydrogen and the odouring compounds commonly used in natural gas. Hydrogen should therefore have no deleterious interaction with odorants.<sup>203</sup> Current literature indicates that a new odorant is not required, but that the quantity of odorant would need to be adjusted according to the percentage of hydrogen added to the gas distribution network. The network operator would need to ensure that the odour of the blended gas is sufficiently maintained at the required limit of the blended gas.

#### 6.2.2.4 Hydrogen production facilities

Whilst the hydrogen production facility itself is outside the scope of this regulatory review, consideration has been given to how these facilities might be regulated under the Act and the Safety and Network Management Regulation. The requirement that “a network operator must not construct, alter, extend, maintain, repair or operate a gas network except in accordance with” a safety and operating plan<sup>204</sup> implies that the construction of a hydrogen production facility with the purpose of supplying a distribution network could potentially also be captured via adequate consideration within the network operator’s safety and operating plan. Further consideration of the regulation of hydrogen production facilities is recommended in order to better inform regulatory changes in this respect, including consideration of the application of the Work Health and Safety Act and subordinate legislation.<sup>205</sup>

---

203 Health and Safety Laboratory, Injecting hydrogen into the gas network – a literature search, page 21, 2015.

204 Gas Supply (Safety and Network Management) Regulation 2013 (NSW), c11(4)(a) – see section for full context.

205 *Work Health and Safety Act 2011* (NSW).

## 6.3 Northern Territory

There are no acts or regulations that apply primarily to safety and technical regulation of natural gas distribution networks in the Northern Territory, particularly in relation to gas quality. Gas specification requirements are instead a contractual requirement determined between buyer and seller. The demand for distributed natural gas in the Northern Territory is significantly less than in the southern states due to reduced heating requirements and lower population density. There is a small number of dedicated gas distribution networks in the Northern Territory that reticulate natural gas, being in the Darwin and Alice Springs regions. There are also limited LPG reticulation networks in the Darwin area, with remaining fuel gas demand being met via bottled LPG.

The Darwin Reticulation Pipeline is regulated under the *Energy Pipelines Act 1981* (NT) (EP Act). The EP Act applies to pipelines with a maximum allowable operating pressure of greater than 1050 kPa, and is an Act providing for “the construction, operation, maintenance and cessation of use or abandonment of pipelines for the conveyance of energy-producing hydro-carbons, and for related purposes.”<sup>206</sup>

Under the EP Act, **energy-producing hydro-carbon:**

***“a naturally occurring or refined hydro-carbon or mixture of hydro-carbons, whether in a liquid, solid or gaseous state, or such a hydro-carbon or mixture of hydro-carbons mixed with other substances as may be present”.***

Energy Pipelines Act 1981 (NT), s3(1)

This definition would apply to addition of up to 10% hydrogen into a pipeline or network regulated under the EP Act. However, the EP Act and its subordinate legislation<sup>207</sup> are silent on gas quality requirements such as those outlined in AS 4564.

---

206 *Energy Pipelines Act 1981* (NT), long title.

207 *Energy Pipelines Regulations 2001* (NT).

More broadly, Darwin and Alice Springs regions reticulated for both natural gas and LPG are regulated the following acts and regulations:

- Dangerous Goods Act 1998 (NT)
- Dangerous Goods Regulation 1985 (NT)

The Dangerous Goods Act 1998 (NT) (DG Act) is an Act to provide for the safe storage, handling and transport of certain dangerous goods.<sup>208</sup>

Under the *Dangerous Goods Regulations 1985* (NT) (the Regulations), *fuel gas* “means a gas or mixture of gases that may be burned with air to produce light, heat or power and includes natural gas, L.P. gas and tempered L.P. gas”.<sup>209</sup> This definition would apply to up to 10% hydrogen in natural gas.

Part 4 of the Regulations is concerned with fuel gas, and regulates such aspects as gasfitting and gas supply, including compliance requirements and applicable standards.<sup>210</sup>

Regulation 177 states:<sup>211</sup>

1. The installation, operation and maintenance of a fuel gas system (other than an autogas system) shall conform to the requirements specified in:
  - (a) AS 1596 “The storage and handling of liquefied petroleum gases”; and
  - (b) AS 5601 “Gas installations – General installations”.
- (2) The installation, operation and maintenance of gas mains shall conform to the requirements specified [in] AS 4645 “Gas distribution networks – Network management”.

---

208 *Dangerous Goods Act 1998* (NT), long title.

209 *Dangerous Goods Regulations 1985* (NT), s2.

210 *Dangerous Goods Regulations 1985* (NT), Part 4, Divisions 2 and 3.

211 *Dangerous Goods Regulations 1985* (NT), Part 4, r177.

The Regulations therefore ensure adequate regulation of gas distribution networks via the requirement to comply with the specifications outlined in AS 4645. The Regulations are, however, silent on gas quality requirements such as those outlined in AS 4564.

Whilst it might become necessary to regulate gas quality with the addition of hydrogen into any gas distribution networks in the Northern Territory, given the small likelihood of establishment of such a network, no recommendations are made for further establishing regulations that would allow for hydrogen in the gas networks in NT. If hydrogen were to be introduced into the gas distribution networks in NT however, consideration would need to be given to whether gas quality could continue to be managed via contractual arrangement, or whether regulation would become necessary.

## 6.4 Queensland

The acts and regulations that govern safety and technical aspects of gas distribution networks in Queensland are:

- Petroleum and Gas (Production and Safety) Act 2004 (Qld)<sup>212</sup>
- Petroleum and Gas (Safety) Regulation 2018 (Qld)
- Petroleum and Gas (General Provisions) Regulation 2017 (Qld)

### 6.4.1 *Petroleum and Gas (Production and Safety) Act 2004*

The *Petroleum and Gas (Production and Safety) Act 2004* (the Act) is an Act about exploring for, recovering and transporting by pipeline, petroleum and fuel gas and ensuring the safe and efficient carrying out of those activities, and for other purposes.<sup>213</sup>

---

212 *The Land, Explosives and Other Legislation Amendment Act 2019* (“LEOLA Act”) includes amendments to the Act; however, most of the amendments to the Act are yet to commence.

213 *Petroleum and Gas (Production and Safety) Act 2004* (Qld), long title.

### 6.4.1.1 Relevant definitions

Among others, the Act includes the following definitions for the purposes of the Act:

- The meaning of **Petroleum** is – <sup>214</sup>
  - (a) a substance consisting of hydrocarbons that occur naturally in the earth's crust; or
  - (b) a substance necessarily extracted or produced as a by-product of extracting or producing a hydrocarbon mentioned in paragraph (a); or
  - (c) a fluid that –
    - (i) is extracted or produced from coal or oil shale by a chemical or thermal process or that is a by-product of that process; and
    - (ii) consists of, or includes, hydrocarbons; or
  - (d) another substance prescribed under a regulation, consisting of, or including, hydrocarbons; or
  - (e) a gas, that occurs naturally in the earth's crust, as prescribed under a regulation.
- The meaning of **Fuel gas** is – <sup>215</sup>
  - (a) LPG; or
  - (b) processed natural gas; or
  - (c) another substance prescribed under a regulation that is similar to LPG or processed natural gas.
- **Processed natural gas** means a substance that – <sup>216</sup>
  - (a) is in a gaseous state at standard temperature and pressure; and
  - (b) consists of naturally occurring hydrocarbons and other substances; and
  - (c) is more than half, by volume, methane; and
  - (d) has been processed to be suitable for use by customers of fuel gas.

---

<sup>214</sup> *Petroleum and Gas (Production and Safety) Act 2004* (Qld), s10(1).

<sup>215</sup> *Petroleum and Gas (Production and Safety) Act 2004* (Qld), s11(2).

<sup>216</sup> *Petroleum and Gas (Production and Safety) Act 2004* (Qld), s11(3).

- The meaning of an **operating plant** includes –
  - (a) a facility that is related to the exploration, production or processing of petroleum; <sup>217</sup>
  - (b) a place, or part of a place at which a following activity is carried out:
    - (i) another activity prescribed under a regulation and associated with the delivery, storage, transport, treatment or use of petroleum or fuel gas. <sup>218</sup>

The application and implications of these definitions are discussed in the following sections.

### 6.4.2 *Petroleum and Gas (General Provisions) Regulation 2017*

Hydrogen is deemed a **fuel gas** where it is used or intended to be used as fuel under s11(2)(c) of the Act, via prescription under the *Petroleum and Gas (General Provisions) Regulation 2017*<sup>219</sup> (GP Regulation). In effect, this prescription allows hydrogen in the gas networks to be regulated under the Act, and the GP Regulation and the *Petroleum and Gas (Safety) Regulation 2018* (see section below).

### 6.4.3 *Petroleum and Gas (Safety) Regulation 2018*

The *Petroleum and Gas (Safety) Regulation 2018* (Safety Regulation) outlines the prescribed quality<sup>220</sup> and odour<sup>221</sup> for fuel gas.

---

<sup>217</sup> *Petroleum and Gas (Production and Safety) Act 2004* (Qld), s670(2)(a).

<sup>218</sup> *Petroleum and Gas (Production and Safety) Act 2004* (Qld), s670(5)(e).

<sup>219</sup> *Petroleum and Gas (General Provisions) Regulation 2017* (Qld), r6(a).

<sup>220</sup> *Petroleum and Gas (Safety) Regulation 2018* (Qld), r72(1).

<sup>221</sup> *Petroleum and Gas (Safety) Regulation 2018* (Qld), r73(1).

### 6.4.3.1 Gas Quality

Processed natural gas is required to comply with the quality specifications of AS 4564 *Specification for general purpose natural gas*.<sup>222</sup> As outlined above, the definition of processed natural gas under the Act includes the wording 'consists of naturally occurring hydrocarbons and other substances'; addition of up to 10% hydrogen into the gas distribution networks would still render the gas 'processed natural gas' according to that definition, provided that 'other substances' are not interpreted as having to be 'naturally occurring'.<sup>223</sup> With the addition of 10% hydrogen the gas would remain more than half, methane, as required by the definition of processed natural gas in the Act.<sup>224</sup>

Addition of hydrogen to the gas networks will not cause non-compliance with the quality requirements of the Safety Regulation, provided the conditions outlined in AS 4564 are met. As outlined in section 5.2.3, compliance with AS 4564 is unlikely to be compromised by the addition of up to 10% hydrogen by into the gas networks. The network operator would need to take steps to ensure compliance with these requirements. See section 5.2.3 for further discussion of gas quality impacts.

### 6.4.3.2 Odourisation

The Act also allows for the Safety Regulation to prescribe the odour requirement for fuel gas to be supplied for consumer use.<sup>225</sup> Considerations for the application of this regulation to the introduction of up to 10% hydrogen in the gas distribution networks are:

- Management of odorant levels to maintain sufficient intensity indicating the presence of gas down to one-fifth of the lower flammability limit of the

---

222 Petroleum and Gas (Safety) Regulation 2018 (Qld), r72(1)(b).

223 Petroleum and Gas (Production and Safety) Act 2004 (Qld), s11(3).

224 Ibid.

225 *Petroleum and Gas (Production and Safety) Act 2004* (Qld), s627, and *Petroleum and Gas (Safety) Regulation 2018* (Qld), c73(1).

blended gas (i.e. managing the dilution effect);

Use of an odorant type compatible with a blend of up to 10% hydrogen in the gas network.

As outlined in section 4.4.7, there are no known chemical incompatibility issues of note between hydrogen and the odorising compounds commonly used in natural gas. Hydrogen should therefore have no deleterious interaction with odorants.<sup>226</sup> Current literature indicates that a new odorant is not required, but that the quantity of odorant would need to be adjusted according to the percentage of hydrogen added to the gas distribution network. The network operator would need to ensure that the odour of the blended gas is sufficiently maintained at the required limit of the blended gas.

### 6.4.3.3 Upstream considerations

Whilst not directly part of the gas distribution networks, hydrogen production facilities were also considered in the review of the Act due to their integral nature to allowing hydrogen in the gas networks, and due to the link in Queensland regulation of gas distribution networks and processing facilities.

Production of hydrogen is not covered by the current legislation, however production of petroleum is. In the same way that hydrogen is prescribed as a fuel gas under GP Regulation 6(a), production of hydrogen could be prescribed to enable regulation under the Act s10(1), by defining hydrogen as petroleum under GP Regulation 5.

If Queensland were to see widespread production of hydrogen, but on a scale that precludes it from regulation as a Major Hazardous Facility (MHF) under the *Work Health and Safety Regulation 2011*, it may make sense to enact changes to the GP Regulation to enable regulation of these facilities as outlined above. Regulation of hydrogen production facilities under this

---

226 Health and Safety Laboratory, *Injecting hydrogen into the gas network – a literature search*, page 21, 2015.

framework would ensure the application of a safety management system, as defined in the Act.<sup>227</sup>

It is noteworthy that the relevant definition of petroleum includes the words 'consisting of, or including, hydrocarbons'.<sup>228</sup> As such, the Act doesn't currently allow for prescription of 100% hydrogen as petroleum under the Act s10(1)(d). For the purposes of prescribing hydrogen as petroleum

to enable regulation of hydrogen production facilities (below the scale that would trigger MHF legislation), careful consideration would need to be given to the wording, to ensure the intent of the prescription is met. This could be achieved provided the mixing point (at which hydrogen is blended with natural gas prior to injection into the gas distribution network) is considered to be included in the definition of a production facility.

Similarly, consideration would need to be given to avoiding duplication of regulation of existing hydrogen production facilities for purposes other than for use as fuel gas (such as for industrial purposes). In particular, consideration should be given to the application of the *Work Health and Safety Act 2011* in these circumstances, and an assessment of implications to both Acts should be made.

#### 6.4.3.4 Downstream impacts

Whilst the scope of this review is not to consider regulatory barriers to allowing up to 10% hydrogen in the gas networks beyond the gas distribution network itself, the direct impact on downstream appliances cannot be ignored. The legislation reviewed in these sections references Australian Standards concerned with the safety and technical requirements for downstream appliances, and further work is required to assess the implications to the various standards referenced throughout the legislation. The work currently underway to assess impacts of up to 10%

---

227 *Petroleum and Gas (Production and Safety) Act 2004* (Qld), Schedule 2.

228 *Petroleum and Gas (Production and Safety) Act 2004* (Qld), s10(1)(d).

hydrogen on downstream appliances, referenced in section 2.6, will aid to inform subsequent review of relevant standards and further inform any regulatory changes contemplated.

## 6.5 South Australia

The acts and regulations that govern safety and technical aspects of gas distribution networks in South Australia are:

- *Gas Act 1997 (SA)*
- *Gas Regulations 2012 (SA)*

The *Energy Products (Safety and efficiency) Act 2000* (EP Act) is a directly related act, applying to appliances and certification. This relationship with the EP Act is discussed in section 6.5.2.3.

### 6.5.1 Gas Act 1997

The *Gas Act 1997* (the Act) is an "Act to regulate the gas supply industry; to make provision for safety and technical standards for gas infrastructure, installations and fitting work; to repeal the Gas Act 1988; and for other purposes".<sup>229</sup>

The Act defines the functions and powers of the Technical Regulator, intended in part for the monitoring and regulation of safety and technical standards in the gas supply industry.<sup>230</sup>

The Act requires that, *inter alia*, a person must not carry on the operation of a distribution system, retailing of gas, or other operation for which a licence is required, without holding a licence under the Act, authorising the relevant operation.<sup>231</sup> Further, the licence is subject to conditions including requiring the gas entity to "prepare, maintain and periodically revise a safety, reliability, maintenance and technical management plan dealing with matters prescribed by regulation".<sup>232</sup>

---

229 *Gas Act 1997 (SA)*, long title.

230 *Gas Act 1997 (SA)*, s7 - 8.

231 *Gas Act 1997 (SA)*, s19.

232 *Gas Act 1997 (SA)*, s26.



### 6.5.1.1 Relevant definitions

In the Act, the following interpretation applies:<sup>233</sup>

- **Gas** means a fuel consisting of hydrocarbons or predominantly of hydrocarbons that is in a gaseous or vapour form when it is at the pressure and temperature of its normal pipeline transportation and utilisation conditions, but does not include anything declared by regulation not to be gas.

The definition of gas would include a blend of up to 10% hydrogen in natural gas, and there is currently no regulation that declares hydrogen not to be gas; therefore the definition of gas in the Act would apply to up to 10% hydrogen (or indeed approaching up to 50% hydrogen) in the gas distribution networks.

### 6.5.2 Gas Regulations 2012

The Gas Regulations 2012 (the Regulations) outline safety and technical requirements, including for gas infrastructure or installation, and for gas supply, quality, etc.

The Regulations interpret **natural gas** as having the same meaning as defined in AS 4564. As discussed in previous sections outlining the impacts to NSW regulations, the meaning of natural gas in AS 4564 does not include hydrogen; however Schedule 2 of the Gas Regulations includes specifications for natural gas, as well as for other gas,<sup>234</sup> which would include hydrogen under the Act. Therefore a blend of up to 10% hydrogen in the gas distribution networks would be covered by the Gas Regulations.

#### 6.5.2.1 Safety and technical requirements

Regulation 37 of the Regulations requires that “gas infrastructure must be designed, operated and maintained to be safe for the gas service conditions and the physical environment in which it will operate and so as to comply with any applicable requirements of AS/NZS 4645, AS/NZS 1596 and AS 2885 or achieve,

---

233 *Gas Act 1997* (SA), s4(1).

234 Gas Regulations 2012 (SA), Schedule 2.

to the satisfaction of the Technical Regulator, the same or better safety and technical outcomes”.<sup>235</sup>

Additionally, Division 6 outlines of the Gas Regulations outlines the requirements of a holder of a licence authorising the operation of a distribution system to prepare, maintain and periodically revise a safety, reliability, maintenance and technical management plan dealing with *inter alia*:

- (a) the safe design, installation, commissioning, operation, maintenance and decommissioning of gas infrastructure owned or operated by the person;<sup>236</sup> and
- (b) the maintenance of as supply of gas of the quality required to be maintained under the Act, these regulations, the person’s licence or the conditions of any exemption granted to the person;<sup>237</sup>

These regulations ensure that the same safety and technical requirements that apply to an existing gas distribution network would also apply to a blend of up to 10% hydrogen, but only in so far as the standards referenced provide for hydrogen.

#### 6.5.2.2 Gas supply and quality requirements

Regulation 38 outlines the gas supply and quality requirements for a distribution network, including that it must:<sup>238</sup>

- be at a safe temperature and pressure and safe in all other respects for the purposes of the system; and
- contain sufficient odorant that is has a distinctive smell to a person with a normal sense of smell at one-fifth of the lower explosive limit in air; and
- comply with the relevant specifications set out in Schedule 2 (unless otherwise agreed between the Technical Regulator and the operator).

---

235 Gas Regulations 2012 (SA), r37(1)(a).

236 Gas Regulations 2012 (SA), r49(2)(a).

237 Gas Regulations 2012 (SA), r49(2)(b).

238 Gas Regulations 2012 (SA), r38(1)(a).

The regulation in effect ensures that the gas supplied is safe in all respects for the purposes of the system generally and specifically that an adequate level of odorant is maintained in the supply. As outlined in section 4.4.7, there are no known chemical incompatibility issues of note between hydrogen and the odourising compounds commonly used in natural gas. Hydrogen should therefore have no deleterious interaction with odorants.<sup>239</sup> Current literature indicates that a new odorant is not required, but that the quantity of odorant may need to be adjusted according to the percentage of hydrogen added to the gas distribution network. The network operator would need to ensure that the odour of the blended gas is sufficiently maintained at the required limit of the blended gas.

Schedule 2 outlines gas specifications for natural gas, liquefied petroleum gas, and other gas. As discussed, hydrogen would fit within the definition of 'other gas' as prescribed by the Act.

The specifications for natural gas are as outlined in AS 4564.<sup>240</sup> As outlined in section 5.2.3, the addition of up to 10% hydrogen into the gas networks has been modelled and is not anticipated to impact the gas quality specifications outlined for natural gas in AS 4564.

The specifications for gas other than natural gas or liquefied petroleum gas include:<sup>241</sup>

- (a) it must contain less than 12 mg/m<sup>3</sup> of hydrogen sulphide;
- (b) its combustion characteristics must not be more than 10% above or 10% below the limits of –
  - (i) the Wobbe index; and
  - (ii) the flame speed factor; and
  - (iii) the sooting index

---

239 Health and Safety Laboratory, Injecting hydrogen into the gas network – a literature search, page 21, 2015.

240 Gas Regulations 2012 (SA), Schedule 2, c1.

241 Gas Regulations 2012 (SA), Schedule 2, c3.

as derived from the test gases for the type of gas referred to in the Test Gas Table set out in the Australian gas appliance standards listed in AS 3645 *Essential requirements for gas equipment*.

The above limit on hydrogen sulphide content is greater than that prescribed in AS 4564 for natural gas, and would therefore not be expected to be compromised by the addition of up to 10% hydrogen by into the gas networks.

Schedule 1 of the Gas Regulations outlines the calculations for flame speed factor and sooting index, which would need to be utilised by the network operator to ensure compliance with Schedule 2 if hydrogen is added to a gas distribution network. As outlined in sections 4.1.6 and 4.1.7, the flame speed would be expected to increase by approximately 10% with the addition of 10% hydrogen into the gas network, and the sooting index would be expected to decrease. The network operator would need to apply the calculations outlined in Schedule 1 to confirm the gas supply is within the limits set out by the Gas Regulations.

### 6.5.2.3 Downstream impacts

The scope of this regulatory review was limited to the implications of addition of up to 10% hydrogen by to the gas distribution networks. However the potential impact of this change on downstream appliances cannot be ignored. In the case of South Australian legislation, downstream appliances are directly considered in the Gas Regulations.<sup>242</sup> In addition to the requirements outlined above, Division 6 of the Gas Regulations further requires a safety, reliability, maintenance and technical management plan to deal with the following matters:

- a) ensuring that gas supply is suitable for each gas installation situated in a place that will be connected or reconnected to the distribution system;<sup>243</sup> and

---

242 Gas Regulations 2012 (SA), r49(2)(e).

243 Gas Regulations 2012 (SA), r49(2)(d).

- b) ensuring that an appropriate level of examination and testing of installations (including appliances) is carried out on the new connection of gas supply to a place to provide assurance of the safety of gas installations.<sup>244</sup>

This in effect requires links the requirements of the Gas Regulations to those of the Energy Products (Safety and Efficiency) Act 2000 (the EP Act), which is “an Act to make provisions relating to the safety, performance, energy efficiency and labelling of products powered by electricity, gas or some other energy source; and for other purposes”.<sup>245</sup> The EP Act applies the same meaning of **gas** as the Gas Act, and would therefore also apply to a blend of up to 10% hydrogen by in natural gas.<sup>246</sup> As outlined in section 2.6 it is recommended that a review of downstream impacts be completed to ensure that these impacts are adequately addressed per the requirements of Division 6 of the Gas Regulations. It is further recommended that the EP Act also be reviewed to assess implications of the addition of up to 10% hydrogen into the gas networks on downstream appliances.

## 6.6 Tasmania

The acts and regulations that govern safety and technical aspects of gas distribution networks in Tasmania are:

- *Gas Act 2000 (Tas)*
- *Gas Safety Regulations 2014 (Tas)*

### 6.6.1 Gas Act 2000

The Gas Act 2000 (the Act) is “an Act to regulate the distribution and retailing of gas, to provide for safety and technical standards for gas installations and gas appliances and for related purposes.”<sup>247</sup>

<sup>244</sup> Gas Regulations 2012 (SA), r49(2)(e).

<sup>245</sup> *Energy Products (Safety and Efficiency) Act 2000 (SA)*, long title.

<sup>246</sup> *Energy Products (Safety and Efficiency) Act 2000 (SA)*, s3(1).

<sup>247</sup> *Gas Act 2000 (Tas)*, long title.

The Act includes Parts covering administration of the Act; the gas supply industry; and safety of infrastructure, installations and appliances.

#### 6.6.1.1 Relevant definitions

The Act includes the following interpretations for the purposes of the Act:<sup>248</sup>

- **Distribution system** means the whole or a part of a pipe or a system of pipes and equipment for use for, or in connection with, the distribution and delivery of gas to persons for consumption, and includes a pipeline, or class of pipelines, declared under section 3(3) of the Gas Pipelines Act 2000 to be treated as not being a transmission pipeline for the purposes of that Act.
- **Facility** means –
  - (a) a distribution system; or
  - (b) a facility or service for the control of the conveyance of gas; or
  - (c) a facility for the measurement of gas where the facility is connected to a distribution system; or
  - (d) a service for the sale by retail of gas
- **Gas** means –
  - (a) natural gas; or
  - (b) liquefied petroleum gas; or
  - (c) any other gaseous fuel, being a gaseous fuel that is not declared by the regulations to be excluded from the operation of this Act
- **Gas distributor** means a gas entity licensed under section 24 to operate a distribution system
- **Natural gas** means a substance –
  - (a) which is in a gaseous state at standard temperature and pressure and which consists of naturally occurring hydrocarbons, or a naturally occurring mixture of hydrocarbons and non-hydrocarbons, the principal constituent of which is methane; and

<sup>248</sup> *Gas Act 2000 (Tas)*, s3(1).

- (b) which has been processed to be suitable for consumption – but does not include anything declared by the regulations not to be natural gas

- **Quality**, in respect of gas, includes odourisation, purity, temperature, pressure and composition

There is currently no regulation declaring hydrogen to be a gaseous fuel that is excluded from the operation of the Act. The Act can therefore be considered to apply to a blend of up to 10% hydrogen in natural gas that is intended for use as a gaseous fuel.

### 6.6.1.2 Review

The Act requires that a person must not construct or operate a distribution system or carry out any other activity for which a licence is required by the regulations, unless the person holds an applicable licence.<sup>249</sup> This in effect ensures that hydrogen cannot be injected into the gas distribution networks without an appropriate licence.

Under Part 3 of the Act, Section 38A declares that the Minister or the Regulator may issue gas codes, and further that a code may provide for any matter relating or incidental to the distribution and retailing of gas.<sup>250</sup> The authority to issue codes is a mechanism by which specific standards or requirements for the introduction of hydrogen into the gas networks could be further regulated, should it be deemed necessary.

Part 4 of the Act is concerned with safety of infrastructure, installation and appliances.<sup>251</sup> In this Part, a gas entity is required to ensure that, as far as practicable, the gas it conveys meets the prescribed standards of quality, and complies with any other requirements.<sup>252</sup> Gas quality requirements are prescribed in the associated Gas Safety Regulations 2014 (see next section); for 10% hydrogen to be permissible under the Act, the prescribed gas quality specifications would need to be met.

---

249 *Gas Act 2000* (Tas), s21.

250 *Gas Act 2000* (Tas), s38A(1) – (2).

251 *Gas Act 2000* (Tas), Part 4.

252 *Gas Act 2000* (Tas), s51(1).

The Act further outlines requirements for a gas entity to submit to the Director of Gas Safety a safety and operating plan for each of its facilities, demonstrating compliance with the prescribed codes and standards.<sup>253</sup> Safety and operating plan requirements are prescribed in the Gas Safety Regulations 2014.

### 6.6.1.3 Downstream impacts

From Part 4, Division 3 onwards, the Act deals with such aspects as gas installations and gas fitting work, downstream of the gas distribution network. These aspects are beyond the scope of this review, but should be reviewed to further inform the implications to the Act of introduction of up to 10% hydrogen into the gas networks, including on downstream appliances and gas installations.

## 6.6.2 Gas Safety Regulations 2014

The Gas Safety Regulations 2014 (the Regulations) cover safety and technical requirements; design and construction of facilities; safety and operating plan requirements; safety management system contents; incident reporting; and gas fitting and gas installations works.<sup>254</sup>

The Regulations include definitions for heating value, lower explosive limit, and relative density.<sup>255</sup>

### 6.6.2.1 Gas quality

Part 2 of the Regulations is concerned with technical and safety requirements, and prescribes the required gas quality.<sup>256</sup> The gas qualities prescribed in the Regulations match those in AS 4564 Table 3.1, but do not include all of the qualities specified in AS 4564.<sup>257</sup>

As discussed in section 5.2.3.2, addition of 10% hydrogen into the gas distribution networks is not expected to cause non-compliance with these

---

253 *Gas Act 2000* (Tas), s54.

254 Gas Safety Regulations 2014 (Tas), Parts 2 - 8.

255 Gas Safety Regulations 2014 (Tas), r3.

256 Gas Safety Regulations 2014 (Tas), r9(2).

257 Standards Australia, AS 4564 – Specification for General Purpose Natural Gas, s3.1, 2011.

specification limits. Therefore the Regulations would not be expected to preclude addition of up to 10% hydrogen into the gas distribution networks as a result of the quality specifications.

The Regulations further prescribe requirements for measurement and maintenance of gas quality by the gas entity;<sup>258</sup> ability to comply with these requirements would need to be confirmed by the gas entity proposing to introduce up to 10% hydrogen into the gas distribution network. Of particular consideration for introduction of hydrogen into the gas network is the requirement not to vary by more than 1% from the claimed heating value used by the gas entity as the basis for its charges to the consumer for the gas.<sup>259</sup>

### 6.6.2.2 Odorant

Regulation 14 prescribes odorant requirements for a gas distribution system. Tasmania differs from typical regulation of odorant requirements, in that the odorant must give the gas conveyed in a distribution an odour that:<sup>260</sup>

- is distinctive, unpleasant and non-persistent; and
- when the gas is discharged, indicates throughout the discharge the presence of gas down to the lower explosive limit in air; and
- exists throughout the vaporisation the vaporisation range of the gas from the liquid state.

As outlined in section 4.4.7, there are no known chemical incompatibility issues of note between hydrogen and the odouring compounds commonly used in natural gas. Hydrogen should therefore have no deleterious interaction with odorants.<sup>261</sup> Current literature indicates that a new odorant is not required, but that the quantity of odorant would need to be adjusted according to the percentage of hydrogen added to the gas distribution network. The network

---

258 Gas Safety Regulations 2014 (Tas), r10 - 12.

259 Gas Safety Regulations 2014 (Tas), r11(3).

260 Gas Safety Regulations 2014 (Tas), r14.

261 Health and Safety Laboratory, Injecting hydrogen into the gas network – a literature search, page 21, 2015.

operator would need to ensure that the odour of the blended gas is sufficiently maintained at the required limit of the blended gas.

## 6.7 Victoria

The acts and regulations that govern safety and technical aspects of gas distribution networks in Victoria are:

- *Gas Safety Act 1997 (Vic)*
- *Gas Safety (Safety Case) Regulations 2018 (Vic)*

### 6.7.1 Gas Safety Act 1997

The main purpose of the *Gas Safety Act 1997* (the Act) is to make provision for the safe conveyance, sale, supply, measurement, control and use of gas and to generally regulate gas safety.<sup>262</sup>

The Act also describes the objectives and functions of Energy Safe Victoria under the Act.<sup>263</sup>

#### 6.7.1.1 Relevant definitions

Among others, the Act includes the following definitions for the purposes of the Act:<sup>264</sup>

- **Gas** means any gaseous fuel but does not include any gaseous fuel that is declared under section 4 not to be gas for the purposes of this Act or any provisions of this Act;
- **Gaseous fuel** includes petrochemical feed stock;
- **Quality**, in relation to gas, includes odourisation, purity, temperature, pressure and composition.

There are currently no declarations under Section 4 of the Act that would exclude hydrogen from the definition of gas for the purposes of the Act. The Act can therefore be considered to apply to a blend of up to 10% hydrogen intended for use as a gaseous fuel.

Section 33 of the Act requires that gas conveyed or sold to a customer for use in a gas installation meets the prescribed standards of quality and any other prescribed requirements.<sup>265</sup>

---

262 *Gas Safety Act 1997 (Vic)*, s1.

263 *Gas Safety Act 1997 (Vic)*, s9 and 10.

264 *Gas Safety Act 1997 (Vic)*, s3.

265 *Gas Safety Act 1997 (Vic)*, s33.

Section 34 of the Act requires that “a gas company must not knowingly supply or sell gas for use in a gas installation which is unsafe”, nor “which does not comply with the Act or the regulations except in the prescribed circumstances”.<sup>266</sup>

The effect of these sections is that hydrogen could only be lawfully injected into the gas distribution networks if the prescribed quality requirements are met, and it is otherwise safe to do so.

## 6.7.2 Gas Safety (Safety Case) Regulations 2018

The objectives of the *Gas Safety (Safety Case) Regulations 2018* (Safety Case Regulations) are –<sup>267</sup>

- (a) to make provision for safety cases in relation to facilities, gas installations and appliances; and
- (b) to provide for the reporting of gas incidents; and
- (c) to prescribe safety standards for the quality of gas and the testing of natural gas conveyed through a transmission pipeline.

### 6.7.2.1 Gas quality

Part 5 of the Safety Case Regulations outlines the prescribed quality of gas as set out in AS 4564 *Specification for general purpose natural gas*,<sup>268</sup> for natural gas conveyed through a distribution pipeline.<sup>269</sup> Addition of hydrogen to the gas distribution networks will not cause non-compliance with the quality requirements of the Safety Case Regulations, provided the conditions outlined in AS 4564 are met. As outlined in section 5.2.3, compliance with AS 4564 is unlikely to be compromised by the addition of up to 10% hydrogen into the gas networks. See section 5.2.3 for discussion of gas quality impacts.

---

266 *Gas Safety Act 1997* (Vic), s34(1) and (2).

267 *Gas Safety (Safety Case) Regulations 2018* (Vic), r1.

268 Standards Australia, AS 4564-2011 *Specification for General Purpose Natural Gas*.

269 *Gas Safety (Safety Case) Regulations 2018* (Vic), r45.

It should be noted that neither the Act nor the Safety Case Regulation define the term ‘natural gas’, however the term ‘gas’ is defined in the Act as outlined above. Whilst hydrogen is not generally considered natural gas under the ordinary definition of the term, it is not specifically excluded (there is no definition to include or exclude it), and, as outlined under the definition of ‘gas’, hydrogen can be considered a gaseous fuel. Where a company is supplying natural gas (within the ordinary meaning of the term), the Safety Case Regulation would apply. The gas quality prescribed by the Safety Case Regulation should therefore be considered to apply to a blend of up to 10% hydrogen in the gas networks, provided the company supplying the gas can comply with its safety case.

### 6.7.2.2 Odourisation

Part 5 of the Safety Case Regulations also outlines the odour requirements for gas, specifying that “it is a prescribed standard of quality that all gas must –<sup>270</sup>

- a. have an odour which is distinctive and unpleasant; and
- b. have an odour level that is discernible at one-fifth of the lower explosive limit of the gas”.

As with other states, considerations for the application of this regulation to the introduction of up to 10% hydrogen in the gas distribution networks are:

- Management of odorant levels to maintain sufficient intensity indicating the presence of gas down to one-fifth of the lower flammability limit of the blended gas (i.e. managing the dilution effect);
- Use of an odorant type compatible with a blend of up to 10% hydrogen in the gas network

As outlined in section 4.4.7, there are no known chemical incompatibility issues of note between hydrogen and the odourising compounds commonly used in natural gas. Hydrogen should therefore have no deleterious interaction with odorants.<sup>271</sup> Current

---

270 *Gas Safety (Safety Case) Regulations 2018* (Vic), r46.

271 Health and Safety Laboratory, *Injecting hydrogen into the gas network – a literature search*, page 21, 2015.



literature indicates that a new odorant is not required, but that the quantity of odorant would need to be adjusted according to the percentage of hydrogen added to the gas distribution network. The network operator would need to ensure that the odour of the blended gas is sufficiently maintained at the required limit of the blended gas.

### 6.7.2.3 Exemptions

Safety Case Regulation 50 states that Energy Safe Victoria (ESV) may “exempt a safety case from any of the requirements of these Regulations”, or “exemption from compliance with a prescribed standard of quality” as it deems safe to do so.<sup>272</sup> This highlights that whilst requirements for gas quality and odorisation are prescribed, ESV may grant exemption from a specific requirement if it deems such exemption safe and appropriate to do so.

### 6.7.2.4 Downstream impacts

Whilst the scope of this review is not to consider regulatory barriers to allowing up to 10% hydrogen in the gas networks beyond the gas distribution network itself, the direct impact on downstream installations cannot be ignored. As outlined in section 5.2.7.1, the Gas Safety Act governs for the safe conveyance, sale, supply, measurement, control and use of gas and to generally regulate gas safety.<sup>273</sup> This includes allowing for the regulation of gas installations, which is done so under the Gas Safety (Gas Installation) Regulations 2018 (Gas Installation Regulations).<sup>274</sup> The Gas Installation Regulations reference Australian Standards concerned with the safety and technical requirements for downstream appliances,<sup>275</sup> and further work is

---

272 See Gas Safety (Safety Case) Regulations 2018 (Vic), r50(1) for complete wording.

273 *Gas Safety Act 1997* (Vic), s1.

274 Gas Safety (Gas Installation) Regulations 2018 (Vic).

275 Within the Gas Installation Regulations, Australian Standards referenced include AS 3814 ‘Industrial and commercial gas-fired appliances’, in r13, and AS/NZS 5061.1 ‘Gas Installations: General Installations’ and AS/NZS5601.2 ‘Gas Installations: LP Gas Installations in caravans and boats for non-propulsive purposes’ in r12.

required to assess the implications of addition of up to 10% hydrogen into the gas networks to the various standards referenced throughout the legislation. The work currently underway to assess impacts of up to 10% hydrogen on downstream appliances, referenced in section 2.6, will inform subsequent review of relevant standards and further inform any regulatory changes contemplated.

## 6.8 Western Australia

The acts and regulations that govern safety and technical aspects of gas distribution networks in Western Australia are:

- *Gas Standards Act 1972 (WA)*
- *Gas Standards (Gas Supply and System Safety) Regulations 2000 (WA)*

### 6.8.1 Gas Standards Act 1972

The Gas Standards Act 1972 (Standards Act) is “an Act to regulate the standards of quality, pressure, purity and safety of gas supplied and the standards and safety of gas installations and gas appliances; to provide for the supervision and control of persons concerned in, and to regulate the practice of, gasfitting; to repeal the *Gas (Standards) Act 1947*, and for incidental other purposes.”<sup>276</sup>

#### 6.8.1.1 Relevant definitions

Among others, the Standards Act includes the following definitions for the purposes of the Act:<sup>277</sup>

- **Gas** means any gas or mixture of gases intended for use as fuel for gas appliances or for use in any chemical process;
- **Gas appliance** means any appliance that consumes gas as fuel;
- **Supply**, in relation to gas, includes to have in possession with intent to supply any consumer or consumers.
- **Undertaker** means any licensee within the meaning

---

276 *Gas Standards Act 1972* (WA), long title.

277 *Gas Standards Act 1972* (WA), s4.

of the Energy Coordination Act 1994 and any local government, regional local government, body corporate, firm or person making or supplying gas other than solely for its or his own use.

As indicated by its long title, the Standards Act regulates technical and safety aspects of gas distribution networks as well as the downstream gas installations and gas appliances. The sections of the Act specific to supply of gas in the gas distribution networks are sections 8 – 11, which relate to: gas heating value; changes to prescribed characteristics of gas supplied; testing of gas; and defence against changes in gas heating value, respectively.<sup>278</sup>

The definition of *gas* in the Act would include hydrogen intended for use as fuel gas; as such the Act would apply to a blend of up to 10% hydrogen in the gas distribution networks.

### 6.8.2 Gas Standards (Gas Supply and System Safety) Regulations 2000

The Gas Standards (Gas Supply and System Safety) Regulations 2000 (Gas Standards Regulations) prescribe the standards for gas supplied, including natural gas and LPG; metering requirements; entry and commingling of gas of different qualities; distribution system safety and gas plant safety.<sup>279</sup>

The following terms and their definitions are used in the Gas Standards Regulations:<sup>280</sup>

- **Distribution system** has the same meaning as it has in section 3 of the Energy Coordination Act 1994\*;
- **Gas plant** means –
  - (a) any system of pipes, equipment or apparatus utilised for the purpose of –
    - (i) Manufacturing, treating or storing gas with a view to supplying it to consumers through a distribution system; or
    - (ii) Converting gas from one form to another with a view to supplying it to consumers through a distribution system;
- and
- (b) any equipment or apparatus utilised in conjunction with anything referred to in paragraph (a), but does not include anything referred to in paragraph (a) or (b) that is connected to a pipeline within the meaning of the *Petroleum Pipelines Act 1969*.
- **Natural gas** means a hydrocarbon gas, in a liquefied or vapour form, consisting mainly of methane
- **Network operator** –
  - (a) means an undertaker who operates a distribution system; and
  - (b) in relation to a prescribed activity for the purposes of a distribution system, includes any contractor, and any subcontractor, to the system’s network operator who is contracted to carry out the prescribed activity;
- **Prescribed activity** means anything related to the conveyance, control, supply or use of gas done by, for, or with the authority of, the network operator in the course of the construction, maintenance, repair or operation of any part of a distribution system
- **Safety case** means a document that sets out the safety management and technical practices and procedures to be followed by –
  - (a) a network operator in the operation of a distribution system; or
  - (b) a plant operator in the operation of a gas plant,
 as the case requires.

278 *Gas Standards Act 1972 (WA)*, s8 - 11.

279 *Gas Standards (Gas Supply and System Safety) Regulation 2000 (WA)*, Parts 2 – 5.

280 *Gas Standards (Gas Supply and System Safety) Regulation 2000 (WA)*, Part 1, r3.

281 *Ibid.*

The Gas Standards Regulations also include a number of gas quality definitions, such as higher heating value and lower heating value.<sup>281</sup>

\*Under the *Energy Coordination Act 1994*,

**distribution system** means –<sup>282</sup>

- (a) A system of pipelines, mains, and gas service pipes, designed to operate at a pressure of less than 1.9 megapascals, for the transportation of gas to customers; or
- (b) Any other part of the gas distribution system (as defined in section 90 of the Gas Corporate Act 1994 repealed by section 93 of the Gas Corporation (Business Disposal) Act 1999) at the time when a distribution licence is first issued for all or any part of that system (regardless of the pressure at which it is designed to operate),

*And any associated apparatus, facilities, structures, plant or equipment.*

### 6.8.2.1 Gas quality

Part 2 of the Gas Standards Regulations prescribes the standards for gas supplied. Division 2 of this Part prescribes the standards for *natural gas*.<sup>283</sup> As indicated by the meaning of *natural gas* outlined above, a blend of up to 10% hydrogen in a gas distribution network would fall within the meaning of natural gas, as it would remain a 'hydrocarbon gas, in a liquefied or vapour form, consisting mainly of methane'.<sup>284</sup>

Regulation 5 prescribes the quality of gas supplied to consumers, and specifies compliance with AS 4564-2011 *Specification for general-purpose natural gas* Table 3.1.<sup>285</sup> Addition of up to 10% hydrogen into the gas distribution networks would not be expected to cause deviation outside these specification limits. However, an undertaker supplying a blend of up to 10% hydrogen into the gas distribution networks would need to ensure compliance with AS 4564 Table 3.1.

---

282 *Energy Coordination Act 1994* (WA), s3(1).

283 Gas Standards (Gas Supply and System Safety) Regulation 2000 (WA), Part 2, Division 2, r5 - 6.

284 Gas Standards (Gas Supply and System Safety) Regulation 2000 (WA), Part 1, r3.

285 Gas Standards (Gas Supply and System Safety) Regulation 2000 (WA), Part 2, Division 2, r5(2)(a).

### 6.8.2.2 Odour

Regulation 5 also requires odourisation of natural gas supplied to a consumer through a distribution system in accordance with Regulation 6, and that it is subject to periodic sampling to determine the effectiveness of the odourising.<sup>286</sup>

Regulation 6 prescribes requirements for odourising natural gas, requiring an odorant that –<sup>287</sup>

- (a) is distinctive, unpleasant and non-persistent; and
- (b) when the gas is discharged, throughout that discharge indicates to a person with a normal sense of smell the presence of gas down to  $\frac{1}{5}$  the lower explosive limit in air; and
- (c) complies with the requirements for natural gas set out in Schedule 1.

Schedule 1 sets out odorant levels for various gases, vapours and types of odorant, which an undertaker would need to comply with when introducing a blend of up to 10% hydrogen into the gas networks.<sup>288</sup> The effect of these regulations is that the same level of quality control that applies to a traditional natural gas distribution network would also apply to a blend of up to 10% hydrogen in the gas distribution networks

### 6.8.2.3 Safety case

Part 4 of the Gas Standards Regulations is concerned with distribution system safety, and requires that a network operator must submit a safety case to the Director for the distribution system of the network

---

286 Gas Standards (Gas Supply and System Safety) Regulation 2000 (WA), Part 2, Division 2, r5(2)(e).

287 Gas Standards (Gas Supply and System Safety) Regulation 2000 (WA), Part 2, Division 2, r6(a) – (c).

288 Gas Standards (Gas Supply and System Safety) Regulation 2000 (WA), Schedule 1.

operator.<sup>289</sup> Regulation 27 further prescribes compliance, where applicable, with:<sup>290</sup>

- (a) AS/NZS 4645.1:2018 *Gas distribution networks Part 1: Network management*;
- (b) AS 2885.1-2012 *Pipelines – Gas and liquid petroleum Part 1: Design and construction*;
- (c) AS 2885.3-2012 *Pipelines – Gas and liquid petroleum Part 3: Operation and maintenance*.

This in effect would require the network operator to ensure continued compliance with the relevant standards with the addition on up to 10% hydrogen in the gas distribution networks. As outlined in sections 0, compliance with AS/NZS 4645.1, AS 2885.1 and AS 2885.3 is not prohibitively problematic with the introduction of up to 10% hydrogen in the gas distribution networks.

#### 6.8.2.4 Upstream considerations

Whilst the hydrogen production facility itself is outside the bounds of this review (being the metered injection point into, and metered offtake from a distribution network), consideration has been given to the applicability of Part 5 of the Gas Standards Regulations for the purpose of regulating these production facilities.

Part 5 of the Gas Standards Regulations is concerned with gas plant safety.<sup>291</sup> The meaning of *gas plant* would apply to a hydrogen production facility for the purpose of manufacturing, treating or storing gas with a view to supplying it to consumers through a distribution system.<sup>292</sup> The requirement for a safety case and its application to a hydrogen production facility for the purpose of supplying gas into a distribution system would ensure the same level of regulation as for a traditional natural gas plant.

---

289 Gas Standards (Gas Supply and System Safety) Regulation 2000 (WA), Part 4, Division 3, r27(1).

290 Gas Standards (Gas Supply and System Safety) Regulation 2000 (WA), Part 4, Division 3, r27(2)(a) – (c).

291 Gas Standards (Gas Supply and System Safety) Regulation 2000 (WA), Part 5.

292 Gas Standards (Gas Supply and System Safety) Regulation 2000 (WA), Part 1, r3.

#### 6.8.2.5 Downstream impacts

As indicated in section 6.8.1.1, the Gas Standards Act 1972 (Standards Act) is *inter alia* “an Act to regulate the standards of quality, pressure, purity and safety of gas supplied and the standards and safety of gas installations and gas appliances; to provide for the supervision and control of persons concerned in, and to regulate the practice of, gasfitting.”<sup>293</sup>

While the Gas Standards (Gas Supply and System Safety) Regulations 2000 prescribe requirements for gas supply and system safety,<sup>294</sup> the Gas Standards (Gasfitting and Consumer Gas Installations) Regulations 1999 prescribe requirements for gasfitting and consumer installations.<sup>295</sup> The second of these two regulations has been excluded from this regulatory review due to its application to gasfitting and consumer gas installations, with are outside the scope of this report.

Regulations covering distribution networks and those covering downstream installations are however inextricably linked, and potential impacts of addition of up to 10% hydrogen into the gas networks to downstream appliances cannot be ignored. Further work is required to assess implications to regulations such as the Gas Standards (Gasfitting and Consumer Gas Installations) Regulations 1999, as well as implications to Australian Standards concerned with the safety and technical requirements for downstream appliances. The work currently underway to assess impacts of up to 10% hydrogen on downstream appliances, referenced in section 4.5, will inform subsequent review of relevant standards and further inform any regulatory changes contemplated.

---

293 Gas Standards Act 1972 (WA), long title.

294 Gas Standards (Gas Supply and System Safety) Regulation 2000 (WA).

295 Gas Standards (Gasfitting and Consumer Gas Installations) Regulation 1999 (WA).

## 6.9 Recommendations for state legislation

In addition to recommendations made broadly in relation to review of regulations concerned with downstream installations and appliances (section 2.6.1.3) and hydrogen production facilities (section 2.3.1), recommendations are made for changes specific to particular jurisdictions, as outlined below.

### Australian Capital Territory

In the Australian Capital Territory, the Acts and Regulations pertaining to safety and technical regulation of gas distribution networks do not specifically allow for hydrogen, due to their definition of **gas** as meaning *natural gas* as defined in the National Gas Law (ACT).

*It is recommended that consideration be given to development of a legal framework in the Australian Capital Territory that would allow for regulation of hydrogen in the gas distribution networks. The effect of this recommendation would be to remove uncertainty in relation to the regulation of hydrogen, due to the definition of gas in current legislation. Whilst this uncertainty can be managed via regulation of gas distribution networks with hydrogen added on a case-by-case basis, this action should be considered for immediate commencement due to the timeframes that typically accompany revision of state legislation. It is expected that*

*this recommendation will be driven by government.*

### New South Wales

Regulation of hydrogen is not currently prescribed in the NSW legislation pertaining to safety and technical regulation of gas distribution networks. However, regulation of hydrogen in the gas distribution networks in New South Wales could be achieved by developing a regulation that prescribes either pure hydrogen or a blend of hydrogen in natural gas as *gas*, for the purposes of the Act.

*It is recommended that consideration be given to action that would establish a framework for the regulation of hydrogen in the gas distribution network in NSW. This could include a regulation that prescribes either hydrogen or a blend of hydrogen in natural gas as gas, for the purposes of the Gas Supply Act 1996 (NSW). Whilst regulation can currently be managed on a case-by-case basis, this recommendation should be considered for immediate commencement due to the timeframes that typically accompany revision of state legislation. It is expected that this recommendation will be driven by government.*

It is further recommended that in development of an appropriate regulation, consideration is given more broadly to specifying quality and odour requirements for **gas** (and therefore hydrogen) in NSW.



## 6.10 National gas market regulatory framework

### 6.10.1 Implications for the National Gas Market Regulatory Framework

The following section provides a broad overview of the National Gas Market Regulatory Framework and identifies areas that may require deeper policy consideration if 10%% hydrogen is blended with natural gas at the distribution network. The section is not a legal review and does not provide legal opinion but rather highlights uncertainties that could lead to unintended policy outcomes.

Australia's existing gas supply chain comprises of gas producers who source natural gas from gas fields, gas transmission pipelines which store and transport the natural gas at high pressure, gas distribution pipelines which transport the gas at a lower pressure and customers who buy the gas including electricity generators, large and small businesses and residents.<sup>296</sup>

The National Gas Law, National Gas Rules, National Energy Retail Law, National Energy Retail Rules, supporting Regulations, Procedures and Guidelines provide a national regulatory framework for regulating the gas supply chain. The National Gas Law and National Gas Rules apply to all Australian jurisdictions except the Northern Territory while the National Energy Retail Law and Rules apply to all jurisdictions except Victoria, Western Australia and the Northern Territory.

### 6.10.2 National Gas Law (NGL) and National Gas Rules (NGR)

The NGL is contained in a Schedule to the *National Gas (South Australia) Act 2008* and provides the heads of power for the NGR which are made by Australian Energy Market Commission.

Both the NGL and NGR are applied in each participating jurisdiction by separate application Acts.

---

<sup>296</sup> <http://www.aemo.com.au/About-AEMO/About-the-industry> and <https://www.aemc.gov.au/energy-system/gas>

Section 23 of the NGL contains the National Gas Objective which is to:

*promote efficient investment in, and efficient operation and use of, natural gas services for the long term interests of consumers of natural gas with respect to price, quality, safety, reliability and security of supply of natural gas.*<sup>297</sup>

The NGL and NGR provide a regulatory framework:

- to ensure that third parties have competitive access to transport natural gas through gas transmission and distribution pipelines;
- for the operation of gas markets including the Declared Wholesale Gas Market, Short Term Trading Market, and Gas Trading Exchange;
- for customer connection to the distribution gas network; and
- for retail support obligations between distributors and retailers of natural gas.

#### 6.10.2.1 Third Party Access

Third party access to certain natural gas transmission and distribution pipelines is regulated under the NGL and NGR. The framework provides a process and criteria for determining whether a particular natural gas pipeline should be covered by economic regulation<sup>298</sup> and if so, whether it should be subject to full or light regulation. In deciding whether light regulation should apply the NGL requires that certain prescribed factors relating to competition be considered.

Where a determination is made that a natural gas pipeline should be covered by economic regulation, the NGL and NGR impose a number of obligations that include precluding pipeline operators from preventing or hindering third party access to the pipeline, requiring them to comply with queuing requirements and prescribing ring-fencing conditions including a

---

<sup>297</sup> Section 23 *National Gas (South Australia) Act 2008*, Schedule – National Gas Law

<sup>298</sup> Page 7, *National Gas (South Australia) Bill*, Second Reading, <http://hansardpublic.parliament.sa.gov.au/Pages/HansardResult.aspx#/docid/HANSARD-10-1653>



prohibition on carrying on a related business such as producing or selling natural gas.

Where full regulation applies to a natural gas pipeline, the regulatory framework provides for upfront price and revenue regulation of the pipeline owner/operator (known as a service provider). The NGL and NGR prescribe the process under which prices and revenue are determined under the access arrangement process. The Australian Energy Regulator is responsible for determining the total amount of revenue each service provider can earn over a regulatory period. The access arrangement process encompasses a number of stages that include requiring service providers to submit a proposed access arrangement with proposed pricing to the Australian Energy Regulator, consultation obligations and requirements on the Regulator in making its determination.

Where light-regulation applies to a natural gas pipeline, the full access arrangement process does not apply to the service provider. However, the framework still imposes certain requirements on the service provider such as requiring it to publish the prices and terms and conditions of access to the pipeline on its website.<sup>299</sup>

The NGL and NGR also provide a process for dealing with disputes that arise between users or prospective users and service providers about access to regulated pipelines. The framework allows the Australian Energy Regulator to act as arbitrator and make decisions binding on the parties.

As a further measure to ensure competitive access to pipelines, the framework also imposes obligations on unregulated pipelines which include information provision requirements relating to matters such as access offers and financial information and a binding arbitration framework.<sup>300</sup>

The framework also establishes a capacity trading platform to *trade secondary capacity transportation and*

*a Day Ahead Auction for contracted but un-nominated capacity*<sup>301</sup> that apply to gas transmission pipelines and four designated compressors.<sup>302</sup>

### 6.10.2.2 Gas Markets

While most natural gas is bought and sold under bilateral contracts, the regulatory framework under the NGL and NGR provides for two types of gas markets to facilitate the sale of gas. These are:

- The Short-Term Trading Market (STTM)
- The Declared Wholesale Gas Market (DWGM)

The STTM, which operates in Sydney, Adelaide and Brisbane, is a market for the trading of natural gas at hubs where natural gas transmission pipelines meet the gas distribution networks.<sup>303</sup> The NGR provide the rules for the operation of the STTM which is operated by the Australian Energy Market Operator (AEMO). AEMO describes the STTM as:

*The market itself runs once a day, on the day ahead, for each hub. It uses bids, offers, and forecasts submitted by participants, and pipeline capacities, to determine schedules for deliveries from the pipelines which ship gas from producers to transmission users and the hubs.*<sup>304</sup>

The DWGM, which only operates in Victoria, is a wholesale market that facilitates gas trading between natural gas producers, major gas users and retailers.<sup>305</sup> The NGR also set out the rules for the operation of the DWGM which is also operated and administered by AEMO.

---

301 <https://www.aer.gov.au/wholesale-markets/pipeline-capacity-trading-and-day-ahead-auction>

302 <https://www.aer.gov.au/wholesale-markets/pipeline-capacity-trading-and-day-ahead-auction>

303 Page 1, Overview of the Short Term Trading Market for Natural Gas, <https://www.aemo.com.au/media/Files/Other/STTM/1130-0679%20pdf.pdf>

304 <https://www.aemo.com.au/Gas/Short-Term-Trading-Market-STTM>

305 <https://www.aemo.com.au/Gas/Declared-Wholesale-Gas-Market-DWGM>

---

299 Rule 36, National Gas Rules

300 Chapter 6A National Gas (South Australia) Act 2008 – Schedule – National Gas Law; Part 23, National Gas Rules

### 6.10.2.3 Natural Gas Services Bulletin Board

In addition to the wholesale gas markets, the regulatory framework provides for the publication and maintenance of the Natural Gas Services Bulletin Board by AEMO<sup>306</sup> which is designed to facilitate trade in natural gas and natural gas services, inform decision making and negotiations for access to pipelines through the provision of system and market information.<sup>307</sup> The NGR contain detailed requirements about what information registered entities must provide including the nameplate rating of gas facilities, short term capacity outlooks and daily gas injections and withdrawals data.<sup>308</sup>

### 6.10.2.4 Customer Connection Services

In recognition that gas distributors also have a direct relationship with retail customers, the NGL and NGR provides a connection framework for the provision of connection services including new connections and alterations to existing connections to the gas distribution network. The NGR provides for three types of customer connection services: basic connection services which require minimal or no augmentation, standard connection services which may apply to a particular category of connections and negotiated connections for retail customers seeking non-standard connections or alterations.<sup>309</sup>

### 6.10.2.5 Retail Support Obligations

The inclusion of obligations relating to retail customers in the regulatory framework is further supported by the retail support provisions. These provisions recognise that gas distribution businesses and retailers have

---

306 Rule 146, National Gas Rules, <https://www.aemc.gov.au/sites/default/files/2019-04/NGR%20-%20v45%20-%20Part%2018.PDF>

307 Rule 145, National Gas Rules, <https://www.aemc.gov.au/sites/default/files/2019-04/NGR%20-%20v45%20-%20Part%2018.PDF>

308 National Gas Rule, <https://www.aemc.gov.au/sites/default/files/2019-04/NGR%20-%20v45%20-%20Part%2018.PDF>

309 [Part 12A](#), National Energy Retail Rules

obligations to their shared retail customers. It also recognizes that retailers are responsible for billing retail customers including the collection of charges for distribution services. Accordingly, the NGR requires a retailer to pay a distributor for distribution services collected from retail customers and allows a distributor to request credit support from a retailer in limited circumstances where the retailer has not paid the distributor.<sup>310</sup>

### 6.10.3 National Energy Retail Law (NERL) and National Energy Retail Rules (NERR)

The NERL is contained in a Schedule to the *National Energy Retail Law (South Australia) Act 2011* and provides the heads of power for the NERR which are made by the Australian Energy Market Commission. Both the NERL and NERR are applied in each participating jurisdiction by separate application Acts. While the law and rules provide a national framework, the extent of their application is determined by each jurisdiction and do not apply in Victoria, Western Australia or the Northern Territory.

The NERL and NERR provide a consumer protection framework for residential and small business consumers of energy by regulating the activities of retailers and distributors with retail customers.

Broadly, the framework covers provisions relating to:

- the relationship between retailers and customers such as the obligation to offer supply, retail energy contracts, billing, energy marketing and customer hardship
- the relationship between distributors and customers including customer connection services, connection contracts and disruption to supply;
- the relationship between distributors and retailers including the sharing of information; and
- disconnection and reconnection of energy to a customer's premises, life support equipment, prepayment meters and exempt sellers of energy.

---

310 [Part 21](#), National Gas Rules

Under the framework retailers are responsible for the sale of energy while distributors are responsible for the supply of energy including quality of supply.

#### 6.10.4 Implications for the National Regulatory Framework

The national regulatory framework governing Australia's natural gas markets is designed around the existing gas supply chain which sees natural gas that is sourced from gas fields being transported via high pressure gas transmission pipelines to lower pressured smaller distribution gas pipelines to end-use customers.<sup>311</sup> The framework seeks to ensure that the sale and supply of natural gas is provided in an efficient and competitive manner and offers a suite of energy specific consumer protections. This is achieved through the regulation of wholesale gas markets and third party access to gas pipelines that are owned and operated by services providers to allow for the haulage of natural gas from the point of production to the end user.

Fundamentally, the framework regulates the supply chain activities relating to natural gas, as defined under section 2 of the NGL:

**natural gas** means a substance that—

- (a) is in a gaseous state at standard temperature and pressure; and
- (b) consists of naturally occurring hydrocarbons, or a naturally occurring mixture of hydrocarbons and non-hydrocarbons, the principal constituent of which is methane; and
- (c) is suitable for consumption;<sup>312</sup>

The concept of natural gas forms the basis of the regulatory framework with:

---

311 <http://www.aemo.com.au/About-AEMO/About-the-industry> and <https://www.aemc.gov.au/energy-system/gas>

Section 23 National

312 Section 2, *National Gas (South Australia) Act 2008*, Schedule – National Gas Law

- pipelines defined as pipes used for the haulage of **natural gas**;
- producers defined as businesses producing **natural gas**;
- retail customers defined as persons to whom **natural gas** is sold;
- retailers defined as holders of a retailer authorisation in respect of the sale of gas; and
- service providers defined as a person who owns, controls or operates (or intends to own control or operate) a pipeline (used for the haulage of natural gas).<sup>313</sup>

Similarly, the Short-Term Trading Market and Declared Wholesale Gas Market are defined as markets for the supply of **natural gas** and the consumer protection framework only applies to sale and supply of **natural gas**.

In this regard, the framework's reliance on the current definition of natural gas may result in uncertainty around the regulation of gases that are not naturally occurring, and which are not principally constituted by methane such as hydrogen that is produced using man-made processes. Similarly, the framework may be uncertain about supply chain regulation where gas producers add a gas directly into the distribution network as would be the case if 10% hydrogen was blended with natural gas at the distribution network.

The impact of adding gases into the system other than those captured by the natural gas definition must be considered in the context of the regulatory framework and its intentions. If 100% of the gas in the system was outside the definition of natural gas, for example if the system contained pure hydrogen, the framework governing the gas market in Australia would not apply. This is confirmed by Johnson Winter & Slattery Lawyers in their report on adding hydrogen and biogas into the gas network, which found that the framework would not apply to a pure hydrogen network based on the

---

313 Section 2, *National Gas (South Australia) Act 2008*, Schedule – National Gas Law

above definition.<sup>314</sup> However, whether or not, or to what extent, the existing regulatory framework would apply to blending 10% hydrogen with natural gas in the network is not clear. For example, would a pipeline containing blended gas still be considered by a Court of Law as a pipeline for the haulage of natural gas.

While there is nothing in the regulatory framework that directly prohibits the blending of 10% hydrogen into the existing distribution network,<sup>315</sup> the uncertainty around the operation of the framework under this scenario has the potential to hinder the development of hydrogen production in Australia as prospective producers and buyers will be uncertain about terms of sale and supply. Policy makers must therefore turn their minds to:

- the impact of blending 10% hydrogen with natural gas on the operation of the framework; and
- whether the regulatory framework, or parts of it, should apply to gases other than natural gas such as hydrogen.

To help answer these questions, a high-level review of the framework has identified a number of considerations that will require further investigation, these are explained below.

#### 6.10.4.1 Third party access

The NGL and NGR provides a comprehensive framework to assist prospective users of pipelines to gain access.

Pipelines captured by the framework are those for the haulage of natural gas.<sup>316</sup> It is unclear whether blending 10% or more (but less than 100%) of hydrogen with natural gas would mean that the

---

314 Johnson Winter & Slattery Lawyers, "A report on The Injection of Hydrogen and Biogas into gas distribution networks, page 13 and 21.

315 Johnson Winter & Slattery Lawyers, "A report on The Injection of Hydrogen and Biogas into gas distribution networks, page 13 and 21.

316 Section 2, *National Gas (South Australia) Act 2008*, Schedule – National Gas Law

pipeline is no longer hauling natural gas and therefore falls outside of the framework. It may be that if any percentage of hydrogen is blended with natural gas, the pipeline is no longer legally considered to be for the haulage of natural gas.

This uncertainty creates a risk that the regulatory provisions relating to pricing, the terms and conditions of access and dispute resolutions may not apply to pipelines containing blended gas, potentially leaving pipeline users exposed to unfavorable outcomes.

Another uncertainty relates to ring-fencing provisions. The existing framework contains ring-fencing provisions that apply to regulated pipelines and prohibit distribution network service providers from carrying on a related business including producing or selling natural gas and processable gas.<sup>317</sup> The definition of processable gas similarly picks up naturally occurring and principal constituent of methane.<sup>318</sup> Ring-fencing is a paramount concept of the framework as it ensures competition. It is important that this concept is always maintained.

#### 6.10.4.2 Gas Markets

The regulatory framework establishes the Short-Term Trading Market and the Declared Wholesale Market to facilitate the sale of gas. While both markets operate at the transmission level, policy consideration should be given to the impacts on these markets if hydrogen is added directly to the distribution network. The introduction of hydrogen blending at the distribution level will impact on the demand and flows of gas. For example, the Short-Term Trading Market endeavors to balance gas being supplied into the distribution network with gas taken out of the distribution network. The introduction of hydrogen at other points in the distribution network will impact on this balancing.

In addition, it may be worthwhile to consider whether it is necessary to establish similar gas markets at the distribution level to facilitate the trading of hydrogen

---

317 Section 139, *National Gas (South Australia) Act 2008*, Schedule – National Gas Law

318 Section 2, *National Gas (South Australia) Act 2008*, Schedule – National Gas Law

and capture hydrogen flows or whether this can be left to bilateral contracts between hydrogen producers and users.

#### 6.10.4.3 Transparency

The regulatory framework also provides for the publication and maintenance of the national gas services bulletin board which only relates to natural gas services and secondary capacity transactions. The purpose of the bulletin board is to make information available to users to facilitate trade in natural gas and natural gas services; informed and efficient decisions in relation to the provision and use of natural gas and natural gas services; and negotiations for access to pipelines. While the bulletin board currently applies at the transmission level, consideration should be given whether, if hydrogen is blended into the distribution network, similar information should be made available for hydrogen data.

In addition, the framework provides the Australian Energy Regulator and AEMO with information gathering powers for the purpose of carrying out their respective functions including those relating to compliance and reporting. For example, AEMO is required to publish a gas statement of opportunities<sup>319</sup> which provides information relating to the gas supply chain such as forecasts about natural gas reserves, annual peak capacity and constraints affecting gas production facilities and forecast demand for natural gas.<sup>320</sup> This is an important tool that assists with investment decisions and should be maintained for hydrogen production as should any relevant information gathering provisions.

#### 6.10.4.4 Consumer Protections

The NERL and NERR provide consumer protections for the sale and supply of energy to residential and small business customers. The definition of energy under

the NERL means electricity or gas or both,<sup>321</sup> with gas further defined to mean natural gas within the meaning of the NGL.

Under this framework, energy retailers cannot sell energy unless they hold a retailer authorisation or are an exempt seller. If a retailer engages in the sale of 100% hydrogen these requirements would not apply nor would the energy specific consumer protections. Likewise, the framework applies to distributors which, in relation to gas, are gas distribution service providers within the meaning of the NGL.<sup>322</sup> Therefore, the NERL and NERR would not apply to a distribution network that contains 100% hydrogen.

The application of the energy consumer protection framework is not as clear for scenarios where hydrogen is blended with natural gas given that the NERL and NERR relies on the definition of natural gas. While the Australian Consumer Law under the *Competition and Consumer Act 2010* provides general consumer protections relating to the sale of goods and services and will apply to the sale of hydrogen, policy consideration should be given as to whether the energy specific regulation will be, and should be, maintained for blended gases.

Furthermore, recognising that the sale of energy is a competitive activity that benefits from retailer differentiation, policy consideration should be given to possible future scenarios such as the possibility of some retailers exclusively specialising in the sale of hydrogen. If a gas market requires 10% of hydrogen to be contained in the distribution network it is conceivable that, depending on the retailer's gas load requirements, some retailers could purchase 100% hydrogen for their gas needs. Such a case would mean the customers of these retailers' contract to buy 100% hydrogen (even though in physical terms they would still receive a blended gas). Under this scenario these retailers would not be required to be authorised

---

319 Section 91DA, *National Gas (South Australia) Act 2008*, Schedule – National Gas Law

320 Rule 135KB, National Gas Rules

---

321 Section 2, *National Energy Retail Law (South Australia) Act 2011*, Schedule – National Energy Retail Law

322 Section 2, *National Energy Retail Law (South Australia) Act 2011*, Schedule – National Energy Retail Law

retailers which would mean that their customers would not be covered by the consumer protections under the NERL and NERR.

### **6.10.5 Recommendation for national gas market regulatory framework**

The National Regulatory Gas Framework governs Australia's natural gas markets to ensure that the sale and supply of natural gas is provided in an efficient and competitive manner and offers a suite of consumer protections. Importantly, the framework regulates the supply chain for natural gas and does not contemplate the blending of 10% hydrogen into the natural gas blend.

The National Regulatory Gas Framework that applies to gas markets does not contemplate the blending of 10% hydrogen to natural gas in the distribution network. There is uncertainty about whether the definition of natural gas captures the blended gas; what impact blending has on the operation of the existing framework; and to what extent the existing framework applies to blended gas.

*It is recommended that consideration be given to amendments to the national gas market regulatory energy framework to provide for regulation of hydrogen in the gas distribution networks. This recommendation is driven by the need to provide certainty on how the framework will apply and operate with blended gas in the distribution network. This action should commence immediately to ensure that prospective hydrogen producers and buyers have certainty about the terms of sale and supply. It is expected that this recommendation will be driven by government.*

It is anticipated that COAG Energy Council would task officials to work with AEMC and AEMO to provide advice on proposed amendments.

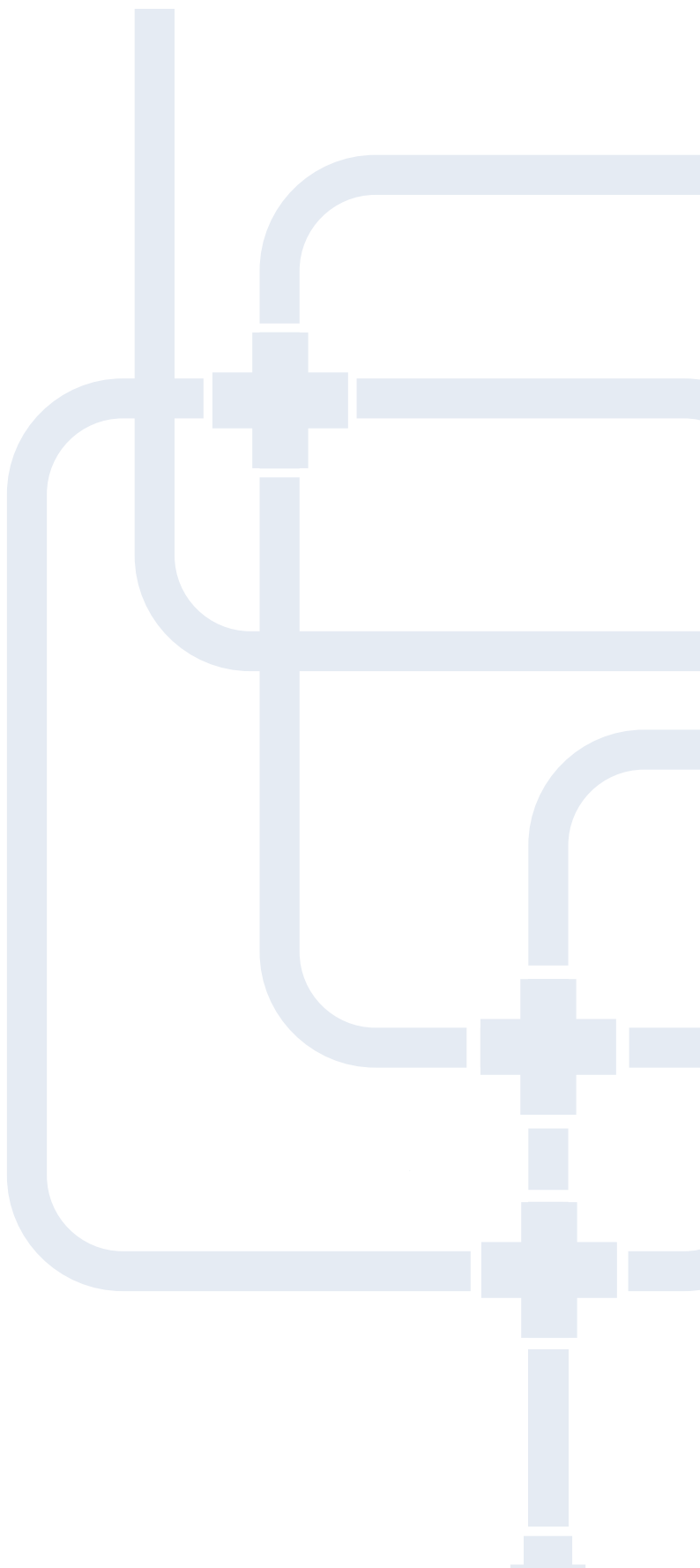



## 6.11 Summary of implications for regulations

Table 19 gives a summary of the implications to the Australian regulations, both state and economic, when hydrogen of up to 10% hydrogen is added to a natural gas distribution network.

**Table 19** Summary of Implications to Australian Regulations

State	Legislation	Implication and Consideration
ACT	<p><i>Utilities Act 2000 (ACT)</i></p> <p>Utilities Act (Technical Regulation) 2014 (ACT)</p>	<p>Under the Utilities Act 2000, gas means natural gas, and natural gas has the same meaning as in the National Gas Law (ACT). Under this definition, it is uncertain whether hydrogen would be recognised in the gas distribution networks, and may therefore not be regulated under the Act.</p> <p>The same definitions apply to the Utilities (Technical Regulation) Act 2014; as such, the same uncertainty regarding application to hydrogen would occur for this Act.</p>
NSW	<p><i>Gas Supply Act 1996 (NSW)</i></p> <p>Gas Supply (Safety and Network Management) Regulation 2013 (NSW)</p>	<p>According to the definition of gas in the Gas Supply Act 1996, regulation of hydrogen or a blend of hydrogen and natural gas under the Act would require hydrogen to be declared a gas by regulation for the purposes of the Act.</p> <p>The Safety and Network Management Regulation is silent on quality standards for LPG or other gas. However, the Secretary can require compliance with any standards, or other quality specification, in order to regulate the quality of hydrogen and natural gas blends in the gas distribution networks.</p> <p>The Safety and Network Management Regulation is silent on odorant requirements for LPG or other gas. The Secretary can, however, require that odorant requirements be included in the Safety and Operating Plan where hydrogen or a blend of hydrogen and natural gas is used in the gas distribution networks.</p> <p>Consideration of the regulation of hydrogen production facilities is recommended to better inform regulatory changes in this regard and to identify opportunities for harmonisation of approach across legislative frameworks.</p>

Table 19 continued

State	Legislation	Implication and Consideration
NT	Dangerous Goods Act 1998 (NT)	Demand for distributed natural gas in the Northern Territory is significantly less than in other states due to reduced heating requirements and lower population density. There are typically no dedicated gas distribution networks in the Northern Territory that reticulate natural gas; instead, there is a limited LPG reticulation network in Darwin, with remaining fuel gas demand being met via bottled LPG.
	Dangerous Goods Regulation 1985 (NT)	Whilst it would be necessary to regulate gas quality with the addition of hydrogen into any gas distribution networks established in the Northern Territory, given the small likelihood of establishment of such a network, no recommendations are made for establishing regulations that would allow for hydrogen in the gas distribution networks in NT.
Qld	Petroleum and Gas (Production and Safety) Act 2004 (Qld)*	There is nothing in the Petroleum and Gas (Production and Safety) Act 2004 (Qld) that would preclude addition of up to 10% hydrogen into the gas networks. Hydrogen has been prescribed under the Petroleum and Gas (General Provisions) Regulation 2017 to be fuel gas under the Act.
	Petroleum and Gas (Safety) Regulation 2018 (Qld)	
	Petroleum and Gas (General Provisions) Regulation 2017 (Qld)	Hydrogen production facilities could be regulated under the Act, requiring a safety management system for an operating plant. In order to do so, hydrogen would need to be prescribed by regulation as petroleum under s10(1) of the Act.
SA	Gas Act 1997 (SA)	The acts and regulations that govern safety and technical aspects of gas distribution networks in South Australia are applicable to the addition of up to 10% hydrogen into the gas distribution networks; as such, addition of hydrogen has no adverse implications for the existing regulatory framework.
	Gas Regulations 2012 (SA)	However the potential impact to downstream appliances cannot be ignored. The South Australian legislation applicable to gas distribution networks also directly considers downstream appliances, and links the requirements of the Gas Regulations to those of the Energy Products (Safety and Efficiency) Act 2000 (the EP Act).  It is recommended that a review of downstream impacts be completed to ensure that these impacts are adequately addressed per the requirements of the Gas Regulations. It is further recommended that the EP Act also be reviewed to assess implications of the addition of up to 10% hydrogen into the gas networks on downstream appliances.

Table 19 continued

State	Legislation	Implication and Consideration
Tas	Gas Act 2000 (Tas)	The interpretations ascribed in the Gas Act 2000 for terms such as distribution system, facility, and gas infrastructure, do not appear to allow for inclusion of hydrogen production facilities in these terms. Consideration should be given to how these facilities would be regulated and whether any legislative gaps or inefficiencies exist.
	Gas Safety Regulations 2014 (Tas)	The Gas Safety Regulations 2014 prescribe requirements for measurement and maintenance of gas quality. A particular consideration for introduction of hydrogen into the gas network is the requirement not to vary by more than 1% from the claimed heating value used by the gas entity as the basis for its charges to the consumer for the gas.
Vic	Gas Safety Act 1997 (Vic)	The Gas Safety Act 1997 is applicable to a blend of up to 10% hydrogen intended for use as a gaseous fuel.
	Gas Safety (Safety Case) Regulations 2018 (Vic)	The Act requires that prescribed quality requirements are met, ensuring that addition of hydrogen into gas distribution networks is compliant with the gas quality specifications outlined in the Gas Safety (Safety Case) Regulations 2018. The Gas Safety Act also allows for the regulation of gas installations under the Gas Safety (Gas Installation) Regulations 2018 (Gas Installation Regulations). The Gas Installation Regulations reference Australian Standards concerned with the safety and technical requirements for downstream appliances; further work is required to assess the implications of addition of up to 10% hydrogen into the gas networks to the various standards referenced throughout the legislation, and to the legislation itself.
WA	Gas Standards Act 1972 (WA)	The definition of gas in the Gas Standards Act 1972 would include hydrogen intended for use as fuel gas; as such the Act would apply to a blend of up to 10% hydrogen in the gas distribution networks.
	Gas Standards (Gas Supply and System Safety) Regulations 2000 (WA)	The Gas Standards (Gas Supply and System Safety) regulations currently allow for regulation of a blend of up to 10% hydrogen in the gas distribution networks in the same way they would apply to a traditional natural gas distribution network.  Further work is required to assess implications to regulations such as the Gas Standards (Gasfitting and Consumer Gas Installations) Regulations 1999, as well as implications to Australian Standards concerned with the safety and technical requirements for downstream appliances.

**Table 19 continued**

State	Legislation	Implication and Consideration
Common		Downstream considerations/impacts should be reviewed across all jurisdictions in order to fully understand implications to appliances and downstream users, of addition of 10% hydrogen to the gas networks.
National Gas Regulation	National Gas (South Australia) Act 2008  National Gas Rules  National Energy Retail Law (South Australia) Act 2011  National Energy Retail Rules	The National Gas Market Regulatory Framework that applies to gas markets does not contemplate the blending of 10% hydrogen to natural gas in the distribution network. There is uncertainty about whether the definition of natural gas captures the blended gas; what impact blending has on the operation of the existing framework; and to what extent the existing framework applies to blended gas.

# 7 RECOMMENDATIONS AND AREAS FOR INVESTIGATION

This section describes the recommendations and areas for further investigation that have been made identified throughout this report. The following recommendations have been identified for injection of up to 10% hydrogen into the natural gas distribution network.

## 7.1 Summary of recommendations

Table 20 provides a summary of the recommendations to address 10% hydrogen in the natural gas distribution network made as part of this report. The following actions and recommendations can be completed following injection of 10% hydrogen into a distribution network (that is, none of these actions necessarily preclude injection of hydrogen on a case by case basis, provided the safety, commercial, technical and social risks are managed), but would facilitate broad scale introduction of hydrogen into the gas distribution networks.

Note that the following recommendations have been made to allow for the injection of up to 10% hydrogen into the gas distribution networks, however in implementing many of these actions, consideration should also be given to whether there would be benefit and/or efficiencies in broadening the scope of any follow-up action to include blends above 10% hydrogen.

The timeframes attributed to the recommendations have been categorised as follows:

- Short term (2020 – 2022)
- Medium term (2022 – 2030)
- Long term (beyond 2030)

Additionally, some actions have been categorised as *immediate start*, either due to a current opportunity

to implement the recommendation (such as an Australian standard review currently in progress), or due to the time typically required to implement such a recommendation (such as regulatory review or reform).

## 7.2 Areas of further interest

Although out of the scope of this report the following areas were identify as being areas of further interest during the period of the study.

### 7.2.1 Transmission networks

As indicated, this was excluded from the scope of this report, but is a logical next step. The National Hydrogen Strategy *gas in the networks working group* identified that distribution network would be initially considered achievable but it was identified that the transmission network is integrally linked. It is therefore suggested that consideration be given to the scope and urgency of a review of impacts of addition of hydrogen into transmission lines.

**Table 20** Summary of the recommendations

No	Topic	Recommendation(s)	Actioner	Action Type	Timeframe
1	AS/NZS 4645	A detailed review and update of the AS/NZS 4645 series for compatibility of hydrogen up to 10% (or beyond), including referenced standards, be completed. This recommendation is required to provide clarity and improve the safety of future hydrogen injection projects. This action is only required in the long term and it should be captured during the next standard revision. It is expected that this recommendation will be driven by the standards committee (AG-008) but will require support from industry and research.	Standard Committee AG-008	Standard revision	Medium
2	AS 4564	AS 4564 should be revised with the following in mind:  Definition and intended application of natural gas reviewed and updated;  Expected Range of HHV found in Table 3.1 note 5 reviewed and updated; and  Expected Range of relative density found in Table 3.1 note 6 reviewed and updated.  This recommendation is required to remove any ambiguity and uncertainty currently around gas composition in AS 4564. Elements of this action could commence immediately as the standard is currently undergoing a revision. It is expected that the recommendation will be driven by the standards committee (AS-010) but will require support from industry and results from current research.	Standard Committee AG-010	Standard revision	Immediate start



No	Topic	Recommendation(s)	Actioner	Action Type	Timeframe
3	AS 2885 (for distribution application)	<p>AS 2885 should be reviewed with respect to the specific threats for hydrogen service and modifications to the standard completed or a code of practice for hydrogen developed in the interim period before the next formal revision.</p> <p>This recommendation is required because AS 2885, as a standard for natural gas and liquid petroleum, was not written with hydrogen in mind. This is a medium term action as the higher pressure sections of the distribution networks are less likely to be targeted as injection points initially, and the standard allows for alternate fluids with special consideration. It is expected that this would be driven by the Australian standards committee in charge of this AS 2885 set of standards (ME-038) with support from research and industry to close the knowledge gaps.</p> <p>It is also recommended that hydrogen is added explicitly as a fluid similar to how carbon dioxide is included in the standard series.</p>	Standard Committee ME-038	Standard revision	Medium
4	Downstream installations and appliances	<p>A technical and regulatory review of the impacts of addition of 10% hydrogen (or beyond) on downstream installations and appliances be undertaken. This recommendation is required to further review potential impacts identified in this report, and to ensure that there are no additional impacts to the operation, safety, efficiency and reliability of the appliances beyond those already identified. This action should start immediately (noting that some aspects of this work are already underway) as it will identify any further barriers to injection. It is expected that this recommendation will be driven by industry and researchers with input from government.</p>	Researchers Industry and NHS Gas networks work stream	Technical and Regulatory review	Immediate start

No	Topic	Recommendation(s)	Actioner	Action Type	Timeframe
5	Feedstock users	A scoping study followed by a technical, commercial and regulatory review of impacts of up to 10% hydrogen to feedstock users that use natural gas in a process be completed. This recommendation is required to confirm the technical and commercial impacts to feedstock users when hydrogen is added to the natural gas. This action should start immediately, in order to understand the impacts to these processes. It is expected that this work will be undertaken by industry and research bodies with input from government. It is recommended that this action be driven by the National Hydrogen Strategy Gas networks work stream.	NHS Gas networks work stream	Technical, commercial and regulatory review	Immediate start
6	MESG	A literature review be completed to identify whether research or testing has previously been completed to confirm MESG. This recommendation is required to ensure that hazard area gas zones remain the same for up to 10% hydrogen. This action is a medium term action as pilot facilities are currently assessing impacts on a case-by-case basis but would be required before hydrogen utilisation in the distribution networks increases. It is expected that this recommendation will be driven by industry with support from research.	Researchers and Industry	Literature review	Medium
7	Injection and blending	A blueprint for injection and blending be developed to ensure gas quality across the network. This is a medium term action; currently this is assessed on a case-by-case basis but development of guidance on industry best practice would streamline the injection process. It is expected that this recommendation will be driven by industry and supported by research and government.	Researchers and Industry	Blueprint development	Medium

No	Topic	Recommendation(s)	Actioner	Action Type	Timeframe
8	Aged Plastic Piping	A literature review be completed and then, if required, further investigation of the impacts of hydrogen, both technical and commercial, to aged plastic piping systems (including suitability of elastomer seals) installed in the gas distribution network be completed. This recommendation is required to confirm that the addition of 10% hydrogen to aged components and piping does not impact the integrity of the pipe. Some aspects of this work are already underway via the FFCRC, and further work should be built on work in progress. It is expected that this recommendation will be driven by industry with support from research.	Researchers and Industry	Literature review	Underway/ Medium
9	Pressure cycling	A review of network operating flow conditions for distribution networks designed to AS 2885 be completed. If significant pressure cycling is found a further investigation of the impacts of pressure cycling in distribution networks should be completed in the form of a literature review. This recommendation is required to confirm there is no increased risk of fatigue due to pressure cycling. It is recommended that this action commence in the short term but conclusions should be relatively quick to determine. It is expected that this recommendation will be driven by research and industry.	Researchers and Industry	Network study and literature review	Short

No	Topic	Recommendation(s)	Actioner	Action Type	Timeframe
10	Network materials review	Develop a detailed database of network materials and establish an assessment program for hydrogen suitability. This recommendation is required to investigate the impacts of various hydrogen concentrations. This is currently underway and is a medium term action because it is not prohibiting injection, but is required for upscale and higher utilisation of hydrogen in the distribution network. It is expected that this recommendations will be driven be industry supported by research.	Researchers and Industry	Review of materials	Underway/ Medium
11	Gas metering and measurement devices	A review of the technical and commercial suitability of gas measurement devices installed in the distribution network be completed for the addition of up to 10% hydrogen. This recommendation is required to ensure that gas measurement equipment used for flow regulation and billing is accurate and safe for hydrogen concentrations of up to 10%. This is a medium term action as pilot facilities are currently assessing on a case-by-case basis, however a broader review would be beneficial for increasing hydrogen utilisation in the distribution networks. It is expected that this recommendation will be driven by industry (both network operators and equipment manufacturers) with support from research.	Industry	Equipment suitability review	Medium

No	Topic	Recommendation(s)	Actioner	Action Type	Timeframe
12	Gas detections devices	A review of the technical suitability of gas detection equipment installed and used in the distribution network for up to 10% hydrogen be completed. This recommendation is required because hydrogen can lead to improper operation or non-detection of hydrogen. This is a medium term action as pilot facilities are currently assessing on a case-by-case basis, but broader understanding will be required as hydrogen utilisation in the distribution networks increases. It is expected that this recommendation will be driven by industry (both network operators and equipment manufacturers) with support from research.	Researchers and Industry	Equipment suitability review	Medium
13	Hydrogen production & delivery facilities	A review of the regulatory framework (including technical standards) for hydrogen production facilities is undertaken, with consideration given to opportunities to develop consistent principles for regulation across all states. This recommendation is intended to develop a clear regulatory pathway for development of hydrogen production facilities, particularly in relation to injection into the gas distribution networks. This is a medium term action as there are currently alternative pathways to the development of production facilities; however opportunity exists for streamlining regulation. It is expected that this recommendation will be driven by both industry and government.  It is recommended that this action be considered by COAG under the National Hydrogen Strategy.	Government (COAG)	Review of technical and regulatory framework	Medium

No	Topic	Recommendation(s)	Actioner	Action Type	Timeframe
14	State legislation	That consideration be given to development of a legal framework in the Australian Capital Territory that would allow for regulation of hydrogen in the gas distribution networks. The effect of is recommendation would be to remove uncertainty in relation to the regulation of hydrogen, due to the definition of gas in current legislation. Whilst this uncertainty can be managed via regulation of gas distribution networks with hydrogen added on a case by case basis, this action should commence immediately due to the timeframes that typically accompany revision of state legislation. It is expected that this recommendation will be driven by government.	Government (ACT)	Review of technical and regulatory framework	Immediate Start/ Medium
15	State legislation	It is recommended that consideration be given to action that would allow for the regulation of hydrogen in the gas distribution network. This could include a regulation that prescribes either pure hydrogen or a blend of hydrogen in natural gas as gas, for the purposes of the Gas Supply Act 1996 (NSW). This recommendation would establish a framework for regulation of hydrogen in the gas networks in NSW. Whilst regulation can currently be managed on a case-by-case basis, this action should be considered for commencement immediately due to the timeframes that typically accompany revision of state legislation. It is expected that this recommendation will be driven by government.	Government (NSW)	Review of technical and regulatory framework	Immediate Start/ Medium



No	Topic	Recommendation(s)	Actioner	Action Type	Timeframe
16	National Gas market regulatory framework	It is recommended that consideration be given to amendments to the national gas market regulatory energy framework to provide for regulation of hydrogen in the gas distribution networks. This recommendation is driven by the need to provide certainty to potential hydrogen producers on how it will apply and operate with blended gas in the distribution network. This action should commence immediately due to the timeframes that typically accompany revision of national legislation. It is expected that this recommendation will be driven by government.	Government (COAG)	Policy Consideration	Immediate Start/ Medium

### **7.2.2 Concentrations exceeding 10% hydrogen**

The scope of this report was to consider concentrations above 10% hydrogen (by volume). This first step was required to remove barriers for injection of low concentrations of hydrogen into the network, however if benefits of hydrogen are to be fully exploited higher concentrations will need to be investigated.

Consideration should be given to whether it is expected that hydrogen concentrations greater than 10% but less than 100% hydrogen will be injected – and how technical and regulatory frameworks should be modified to accommodate the likely outcome.

It is also interesting to note that whilst proposals to review Australian standards can be submitted and actioned at any time, the typical review cycle of Australian standards is approximately five years; potentially longer for revision of legislation. In five years it is expected that higher concentrations of hydrogen in the network could be being investigated so it would make sense to start the complementary processes.

## **7.3 Recommendations for other work streams**

Of the fifteen recommendations delivered under this study, the following are recommended for consideration and implementation by other work streams active under the National Hydrogen Strategy task force.

### **7.3.1 Feedstock users**

A scoping study followed by a technical, commercial and regulatory review of impacts of up to 10% hydrogen to feedstock users that use natural gas in a process should be undertaken. This recommendation is required to confirm the technical and commercial impacts to feedstock users when hydrogen is added the natural gas. This action should start immediately, in order to understand the impacts to these processes.

It is expected that this work will be undertaken by industry and research bodies with input from government. It is recommended that this action be driven by the National Hydrogen Strategy *Industrial users* work stream.

### **7.3.2 Hydrogen production and delivery facilities**

It is recommended that a review of the regulatory framework (including technical standards) for hydrogen production facilities be undertaken, with consideration given to opportunities to harmonise regulation across all states.

This recommendation is intended to develop a clear regulatory pathway for development of hydrogen production facilities, particularly in relation to injection into the gas distribution networks. This is a long term action as there are currently alternative pathways to the development of production facilities; however opportunity exists for streamlining regulation.

It is expected that this recommendation will be driven by both industry and government. It is recommended that this action be considered under the National Hydrogen Strategy *Cross cutting issues* work stream.

# 8 ACKNOWLEDGEMENTS

The National Hydrogen Strategy identified collaboration between industry and government as critical to the success of widespread take up of hydrogen. As such a collaborative approach was taken to ensure the best outcomes for this project.

This report combines both government and industry experience and knowledge to provide a detailed overview of the technical and regulatory issues with hydrogen injection.

GPA Engineering acknowledges the valuable input by the many contributors to the development of this report, and for the contributions and support from the *Hydrogen in the gas networks* working group.

## 8.1 Lead Authors

- Daniel Krosch (GPA Engineering)
- Briony O'Shea (GPA Engineering)

## 8.2 Contributors

*(In alphabetical order)*

- Enzo Alfonsetti (Energy Safe Victoria)
- Klaas van Alphen (Future Fuels Cooperative Research Centre)
- Thomas Ballas (GPA Engineering)
- Paul Beaumont (Queensland Department of Natural Resources, Mines and Energy)
- Phil Colvin (Jemena Energy)
- Tom Dressler (Queensland Department of Natural Resources, Mines and Energy)
- Rob Faunt (South Australian Office of the Technical Regulator)
- Cornelis de Groot (Western Australian Department of Mines, Industry Regulation and Safety)
- Sam Hatwell (GPA Engineering)
- Marshall Holmes (Queensland Department of Natural Resources, Mines and Energy)
- Luke Jureidini (GPA Engineering)
- Nick Kastalein (GPA Engineering)
- Ben Macey (South Australian Department for Energy and Mining)
- Richard McDonough (GPA Engineering)
- Yannick Monrolin (South Australian Office of the Technical Regulator)
- David Moore (New South Wales Department of Planning and Environment)
- Edit Mucsi (South Australian Department for Energy and Mining)
- David Norman (Future Fuels Cooperative Research Centre)
- Nancy Norton (Queensland Department of Natural Resources, Mines and Energy)
- Joe Pisani (Northern Territory Worksafe)
- Ronan Purcell (New South Wales Department of Planning and Environment)
- Gordon Radford (Johnson Winter & Slattery)
- Brett Struck (Northern Territory Department of Primary Industry and Resources)
- Andrew Szacinski (South Australian Office of the Technical Regulator)
- Trevor Tucker (South Australian Office of the Technical Regulator)
- Josh Wickham (GPA Engineering)
- Debbie Wielgosz (South Australian Department for Energy and Mining)
- Tony Williams (GPA Engineering)

- Warren Woodhouse (New South Wales Department of Planning and Environment)
- Jason Wylie (GPA Engineering)

### **8.3 Working Group**

*(In alphabetical order)*

- APA Group
- ATCO
- Australian Gas Infrastructure Group (AGIG)
- Australian Government
- Australian Pipeline and Gas Association (APGA)
- BOC
- Chemistry Australia
- Energy Networks Australia (ENA)
- Energy Safe Victoria (ESV)
- Evoenergy
- Future Fuels Cooperative Research Centre (FFCRC)
- GPA Engineering
- Hydrogen Mobility Australia (HMA)
- Jemena Energy
- New South Wales Department of Planning and Environment
- Northern Territory Department of Primary Industry and Resources
- Orica
- Qenos
- Queensland Department of Natural Resources, Mines and Energy
- South Australian Department for Energy and Mining
- South Australian Office of the Technical Regulator
- Western Australian Department of Mines, Industry Regulation and Safety

# 9 REFERENCES

- Abbott, D. J. (2012). *The impact of natural gas composition variations on the operation of gas turbines for power generation*.
- AEMO. (2017). *Gas Quality Guideline 2017*. AEMO.
- AGN. (2019, 06 24). *Gas Mains Renewal Project*. Retrieved from Australian Gas Networks: <https://www.australiangasnetworks.com.au/our-business/about-us/gas-mains-renewal-program>
- al., M. e. (2012). *A Review of Hydrogen-Natural Gas Blend Fuels in Internal Combustion Engines*.
- Altfeld, K. (2018). *Admissible Hydrogen Concentrations in Natural Gas Systems*.
- ARENA. (2018). *Media Release - Boosting research into exporting renewable hydrogen*. Canberra: Australian Government Australian Renewable Energy Agency.
- Astbury, G. (2008). Spontaneous ignition of hydrogen: review of postulated mechanisms. *Conference on Hydrogen Safety*.
- Bailera, M. (2017). Power to Gas projects review: Lab, pilot and demo plants for storing. *Renewable and Sustainable Energy Reviews*, 392-312.
- Barthelemy, H. (2010). *Effects of pressure and purity on the hydrogen embrittlement of steels*.
- Bathelemy, H. (2005). *Effects of purity and pressure on the hydrogen embrittlement of steels and other metallic materials*.
- Blogg, C. (2003). *Distribution 2003. New Australian Standard – Specification for general purpose natural gas*.
- Brooks, K. B. (2016). *Compatibility of Polymeric Materials Used in the Hydrogen infrastructure*.
- City Gas. (2017). *City Gas Handbook on Gas Supply*. Singapore: City Gas.
- Committee on Advanced Energy Storage Systems. (1979). *Hydrogen as a Fuel*.
- Deloitte Access Economics. (2017). *Decarbonising Australia's gas distribution networks*. Melbourne: Energy Networks Australia.
- DNV GL. (2019, July 01). *Power-to-gas (demonstrations) projects in Europe*. Retrieved from European Power to Gas: <http://europeanpowertogas.com/projects-in-europe/>
- Dodge, L. (1994). *Hydrogen-Air Mixing Evaluation in Reciprocating Engines (NREL)*. National Renewable Energy Lab.
- Economic Insights Pty Ltd. (2014). *Gas utility database*.
- Economic Regulations Authority: Western Australia. (2007). *Gas Exchangeability in Western Australia: Gas Quality specifications of interconnected pipeline systems*. Perth: Western Australian Government .
- El-Ghafour, S. (2010). *Combustion characteristics of natural gas-hydrogen hybrid fuel turbulent diffusion flame*.
- Energy Network Australia. (2019). *Natural Gas Distribution Benchmarking Report 2017-18*. Energy Network Australia.
- Energy Networks Australia. (2014). *Gas Networks Sector Study*.
- Energy Safe Victoria. (2019, 06 24). *Type A and Type B appliance definitions*. Retrieved from Energy Safe Victoria: <https://www.esv.vic.gov.au/technical-information/gas-appliances-and-equipment/type-a-and-type-b-appliance-definitions/>
- EPCRC. (2017). *Identifying the commercial, technical and regulatory issues for injecting renewable gas into the Australian gas network*. Adelaide.
- Fekete, J. R. (2015). *Economic impact of applying high strength steels in hydrogen gas pipelines*.
- Forte, A. (2008). *A Gas Turbine Innovative System for Managing Fuel with Different and Variable Over-Time Wobbe Indexes*.
- Future Fuels Cooperative Research Centre. (2019, July 01). *Research Programs*. Retrieved from Fuel Fuels CRC: <https://www.futurefuelscrc.com/>
- Ganglook, R. P. (2012). *Gaseous hydrogen embrittlement of materials in energy technologies: mechanisms, modelling and future development*.
- Gas Industry Company Limited. (2007). *Review of New Zealand Specification for Reticulated Natural Gas*. Gas Industry Company Limited.

- Gas Technology Institute. (2010). *Review studies of hydrogen use in natural gas distribution systems*.
- Haeseldonckx, D. (2007). *The use of the natural-gas pipeline infrastructure for hydrogen transport in a changing market structure*.
- Hankinson, G. (2009). Ignition energy and ignition probability of methane- hydrogen air mixtures. In: Paper presented at the 3rd International Conference on Hydrogen Safety.
- Health and Safety Laboratory. (2015). *Injecting hydrogen into the gas network – a literature search*.
- Hein, L. (2002). *Effects of Natural Gas Composition Variations on the Operation, Performance and Exhaust Emissions of Natural Gas - Powered Vehicles*.
- Hendricks, R. C. (1972). *Joule-Thompson Inversion Curves and Related Coefficients for Several Simple Fluids*.
- Hossian, M. (2017). *A new practical method to evaluate the Joule-Thomson coefficient for natural gases*.
- Hydrogen Europe. (2019, June 06). *Hydrogen Europe: Projects*. Retrieved from Hydrogen Europe: <https://hydrogeneurope.eu/projects>
- Imamura, D. (2007). *Effect of Sulfur-Containing Compounds on Fuel Cell Performance*. The Electrochemical Society.
- International Electrotechnical Commission. (n.d.). *IEC 60079*.
- Isaac, T. (2019). *Hydeploy: The UK's first hydrogen blending development project*. Gloucestershire: Clean Energy.
- Iskov, K. (2017). Using the natural gas network for transporting hydrogen – ten years of experience.
- IT Power. (2015). *RENEWABLE ENERGY OPTIONS FOR AUSTRALIAN INDUSTRIAL GAS USERS*. Canberra: Australian Government Australian Renewable Energy Agency.
- Jemena. (2018). *Jemena Safety and Operating Procedure*. Jemena Energy.
- Jemena Gas Networks. (2019, 06 24). 2015-20 Access *Arrangement Information*. Retrieved from Australian Energy Regulator: <https://www.aer.gov.au/system/files/JGN%20-%20AA%20review%20-%204%20CURRENT%20PERIOD%20PERFORMANCE%20-%20Appendix%204.3%20EI%20-%20Productivity%20study%20and%20opex%20output%20growth%20-%20PUBLIC.pdf>
- Kiwa. (2016). *Desk study on the development of a hydrogen-fired appliance supply chain*.
- Kuczynski, S. (2018). *Thermodynamic and Technical Issues of Hydrogen and Methane-Hydrogen Mixtures Pipeline Transmission*.
- Larfeldt, J. (2019). Hydrogen as a Fuel in Gas Turbines. *Siemens*. Retrieved from Siemens.
- Lee, J. T. (2002). *The development of a dual injection hydrogen fuelled engine with high power and high efficiency*.
- Malenshek, M. (2009). *Methane number testing of alternative gaseous fuels*.
- Marangon, A. (2011). *Hydrogen – Methane mixtures: dispersion and stratification studies*.
- Marianae, A. (2012). *A Review of Hydrogen-Natural Gas Blend Fuels in Internal Combustion Engines*.
- Marshall, B. (1941). *Density of Natural Gases*.
- Mathurkar, H. (2009). *Minimum Ignition Energy and Ignition probability for Methane, Hydrogen and their mixtures*.
- Messaoudani, Z. L. (2016). *Hazards, Safety and knowledge gas on hydrogen transmission via natural gas frid: A critical review*. Malaya: International Journal of Hydrogen Energy.
- Morrel, R. (2011). GE DLN-2.6 combustion system evolution. *General Electric*.
- Multinet. (2019, 06 24). *Mains Upgrade Program*. Retrieved from Multinet Gas Networks: <https://www.multinetgas.com.au/projects/mains-upgrade-program/>
- Noon, C. (2019, Jan 07). *The Hydrogen Generation: These Gas Turbines Can Run on the Most Abundant Element in the Universe, accessed*. Retrieved from GE Report: <https://www.ge.com/reports/hydrogen-generation-gas-turbines-can-run-abundant-element-universe/>
- NREL. (2017). *Blending of hydrogen into Natural Gas Pipeline Networks: A review of key issues*.
- Orica. (2019, June 28). *Operations*. Retrieved from Orica: <https://www.orica.com/Locations/Asia-Pacific/Australia/Kooragang-Island/Operations#.XRV5n-szZEZ>
- Parrott, K. (2017). *Principle of Natural Gas Odorization*.
- Perry, R. (1984). *Perry's Chemical Engineers' Handbook*.



- Rudy, W. (n.d.). *Experimental and numerical study on spontaneous ignition of hydrogen-methane jets in air*. Brussels.
- Ryan, T. (2008). *Engine Knock Rating of Natural Gases - Methane Number*.
- Sadler, D. (2016). *Leeds City Gate - H21*. Leeds : Northern Gas Networks.
- Sadler, D and Solgaard Anderson, H (2018). *H21 North of England*. Northern Gas Networks.
- SAE International. (1986). *Interchangeability of Gaseous Fuels - The Importance of the Wobbe-Index*.
- Safe Work Australia. (2012). *Guide for major hazard facilities*. Safe Work Australia.
- San Marcki, C. (2008). *Technical Reference on Hydrogen Compatibility of Materials*.
- Schefer, R. (2009). *Visible emission of hydrogen flames*.
- Sivabalakrishnan, R. (2013). *Study of Knocking Effect in Compression Ignition Engine with Hydrogen as a Secondary Fuel*.
- Smith, R. L. (1970). *Joule-Thomson Coefficients of Propane and N-Butane*.
- South Australian Government. (2017). *The South Australian Gas Regulations 2012 Version 1.1.2017*. Adelaide: South Australian Government.
- Speight, J. (2001). *Handbook of Industrial Hydrocarbon Processes*.
- Standards Australia - AS 2885.0. (2018). *AS 2885.0:2018 Pipelines - Gas and Liquid Petroleum Part 0: General Requirements*. Canberra: Standards Australia.
- Standards Australia - AS 2885.6. (2018). *AS 2885.6:2018 Pipelines - Gas and Liquid Petroleum Part 6: Pipeline safety management*. Standards Australia.
- Standards Australia - AS 3645. (2017). *AS 3645:2017 - Essential requirements for gas equipment*. Standards Australia.
- Standards Australia - AS 3814. (2018). *AS 3814:2018 Industrial and commercial gas-fired appliances*. Canberra: Standards Australia.
- Standards Australia - AS 4564. (2011). *AS 4564-2011 Specification for general purpose natural gas*. Canberra.
- Standards Australia - AS 4809. (2017). *AS 4809:2017 - Copper pipe and fittings - Installation and commissioning*. Canberra: Standards Australia.
- Standards Australia - AS 5263. (2013). *AS 5263.0:2013 Gas appliances - General Requirements*. Canberra: Standards Australia.
- Standards Australia - AS/NZS 4645. (2011). *AS/NZS 4645:2011 Gas Distribution Networks*. Standards Australia.
- Standards Australia - AS/NZS 4645.1. (2018). *AS/NZS 4645.1:2018 - Gas distribution network - Network management*. Canberra: Standards Australia.
- Standards Australia - AS/NZS 4645.1. (2018). *AS/NZS 4645.1:2018 - Gas Distribution Networks*. Canberra: Standards Australia.
- Standards Australia - AS/NZS 4645.2. (2008). *AS/NZS 4645.2:2008 - Gas distribution networks - Steel pipe systems*. Standards Australia.
- Standards Australia - AS/NZS 4645.3. (2008). *AS/NZS 4645.3:2008 - Gas distribution networks - Plastic pipe systems*. Standards Australia.
- Standards Australia - AS/NZS 5601. (2013). *AS/NZS 5601:2013 - Gas Installations Set*.
- Standards Australia - AS/NZS 5601.1. (2013). *AS/NZS 5601.1:2013 Gas Installations – General Installations*. Canberra: Standards Australia.
- Standards Australia - AS/NZS 60079.1. (2017). *AS/NZS 60079.1:2017 Explosive Atmospheres*. Standards Australia.
- Standards Australia - AS/NZS 60079.10.1. (2009). *AS/NZS 60079.10.1:2009 - Explosive Gas Atmospheres*. Standards Australia.
- Standards Australia - AS/NZS 60079.20.1. (2009). *AS/NZS 60079.20.1:2009 Explosive Gas Atmospheres*. Standards Australia.
- The Hydrogen Strategy group. (2018). *Hydrogen for Australia's future*. Canberra: Commonwealth of Australia.
- Work Cover Queensland. (2019, June 06). *Workplace Health and Safety Electrical Safety Office Workers' Compensation Regulator*. Retrieved from Work Cover Queensland: <https://www.worksafe.qld.gov.au/injury-prevention-safety/hazardous-chemicals/managing-hazchem-risks/fire-and-explosion-risks>

# APPENDIX 1 DISTRIBUTION NETWORK OWNERSHIP SUMMARY

Distribution Network / Owner	Location / Region Serviced	Approximate Length of Mains (km)
Queensland		
APT Allgas / APA Group	South of the Brisbane River, Gold Coast, Toowoomba and Oakey  *Includes a 1km pipeline servicing an ammonium nitrate plant at Moura	3,218
Australian Gas Networks Qld	Brisbane, Gladstone and Rockhampton	2,703
New South Wales & ACT		
Jemena Gas Networks (NSW)	Sydney, Newcastle/ Central Coast, Wollongong Central West, Central Tablelands, South Western, Southern Tablelands, Riverina and Southern Highlands regions)	25,000
Evoenergy	ACT, Palerang (Bungendore), Queanbeyan and Nowra. Includes CNG refuelling in Fyshwick, ACT	4,911
Essential Energy (NSW Govt.) / AGN Wagga	Wagga Wagga and surrounding areas	1,842
Central Ranges System / APA Group	Tamworth	180
Victoria		
AusNet Services	Western Victoria	11,650
Multinet	Melbourne's eastern and south eastern suburbs, the Yarra Ranges and South Gippsland	9,866
Australian Gas Networks Vic	Melbourne, north eastern and central Victoria, and Albury– Wodonga region	10,447
South Australia		
Australian Gas Networks SA	Adelaide and surrounds  *Includes supply to Port Pirie Lead Smelter downstream of the Port Pirie Meter station	7,950

Distribution Network / Owner	Location / Region Serviced	Approximate Length of Mains (km)
Tasmania		
Tas Gas Networks	Hobart, Launceston, Bell Bay, Devonport, Ulverstone, Wynyard, Burnie, Longford and Westbury  Includes CNG refuelling in Hobart	789
Western Australia		
WA Gas Networks / ATCO Gas Australia	Mid-West and South-West Gas Distribution Systems (including Perth), Kalgourlie Gas Distribution System KGDS, Albany Gas Distribution System	14,000
Esperance Gas Distribution Company (EGDC)	Distribution network in Esperance	40
Northern Territory		
NT Gas Distribution / APA Group	Darwin	19
Australian Gas Networks	Alice Springs	39

# APPENDIX 2 GAS PROPERTIES CALCULATION

## 1. Aim

The aim of this calculation is to determine the suitability of hydrogen gas blends using state regulations and Australian standards.

## 2. Design data

Physical properties for each State and Territory are calculated based on the following two cases,

- Case 1: Typical lean sales gas.
- Case 2: 10% hydrogen blend with typical lean sales gas

The typical lean sales gas compositions are obtained from various credible sources and are shown in the calculation spreadsheet appendix 2 and also as a separate table in appendix 4.

Each state has its own legislation; however all of them apart from Western Australia and the Northern Territory follow AS 4564 standards for natural gas specification and the limits surrounding certain gas properties. A flowchart is attached in appendix 1 to illustrate the national regulations, state regulations and standards used for natural gas in each state.

## 3. Assumptions

The following assumptions have been made:

1. The obtained typical sales gas compositions for each state are lean.
2. Typical lean sales gas for each state in Australia is used as it is generally more conservative in terms of assessing combustion characteristics.
3. Gases will be assessed at standard conditions, 15°C and 101.325 kPa(a).
4. Isomers of the same species have the same flame speed coefficients and air speed requirements.

## 4. Method

The methodology outlines the equations and methods used to calculate certain properties for Case 1 and Case 2. These properties include:

- Wobbe Index, used to determine combustion energy output.
- Flame Speed Factor, used to determine the expansion rate of the flame front in a combustion reaction.
- Sooting Index
- Density and heating values, used to provide the basis for energy density comparison.

The above properties are required by state law to be within specific ranges in order to remain suitable for gas appliances.

### 4.1 Determination of Gas properties

The following gas properties were calculated according to GPA template - Gas Properties, which uses equations from the GPSA handbook.

- Gas Molecular Mass
- Specific gravity relative to air
- Gas standard density
- Gross heating value (Higher heating value)
- Net Heating value (Lower heating value)
- Wobbe Number from GHV

The methods used to calculate the above properties are included in Appendix 3.

The final two gas properties such as flame speed factor and sooting index which are calculated in accordance with the equations prescribed in the South Australia Gas Regulations 2012.

#### 4.1.1 Flame Speed Factor

The flame speed factor (**S**) of a gas is given by-

$$S = \frac{\sum mF_m}{\sum nA_n + 5Z - 18Q + 1}$$

Where-

**F** = Flame speed coefficient for each combustible component

**m** = mole fraction of combustible component that has a flame speed coefficient  $F_m$

**A** = air requirement for each combustible gas component

**n** = mole fraction of combustible component that has an air requirement of  $A_n$

**Z** = the total mole fraction of inert gases (eg  $CO_2$ ,  $N_2$ )

**Q** = the mole fraction of oxygen present.

Note-

1 Based on Gilbert, M.G. and Prigg, J.A., Gas Council Research Communication GC35 (see Transactions of the Institute of Gas Engineers 1956/57)

#### 4.1.2 Sooting Index

The sooting index (**I**) of a gas is given by-

$$I = \frac{1 + 0.01H_2 + 0.01CO}{\sqrt{d}} \cdot \sum aB_a (1 - 0.03O_2)$$

Where-

**B** = the sooting coefficient for each combustible component

**a** = the volume per cent of component that has a sooting coefficient of  $B_a$

**H<sub>2</sub>** = the volume per cent of hydrogen in the gas

**CO** = the volume percent of carbon monoxide in the gas

**O<sub>2</sub>** = the volume per cent of oxygen in the gas

**d** = the relative density of the gas

Note-

1 Based on Schneck, H. and Delbourg, P., Journal des Industries du Gaz, December, 1962.

2 ISO 6976 and GPA-2145-92 reference a hydrogen coefficient of 0.02 instead of 0.01 as per the above. In this calculation we acknowledge that there are two hydrogen coefficients however continue to utilise the South Australian Regulation (2012) value of 0.01.

#### 4.2 Determination of suitability of gases

The calculated combustion characteristics such as the heating value, wobble index, flame speed and sooting index are compared to the design data provided in AS/NZS 5263.0:2017. The South Australian Gas Regulation (2012) states that the combustion characteristics mentioned previously are within  $\pm 10\%$  of the relevant test gases in AS/NZS 5263. Only Test gases N, Nb and Nc are considered relevant as both Na and S contain excessively large amounts of propane that are not present in the lean gas compositions. The composition of these three test gases is shown in the calculation spreadsheet.

The combustion characteristics are also compared to the limits set out in AS 4564 for general purpose natural gas. Every Australian state, except for western Australia and the Northern Territory, adheres to these limits.

A legend is shown on the calculation spreadsheet to distinguish the checks between AS 4564 and the test gasses.

## 5 RESULTS

Table 1 shows a summary of the key combustion characteristics obtained from the calculation spreadsheet. The limits for these combustion properties are shown in table 2. The full calculation spreadsheet can be found in Appendix 2.

**Table 1** Summary of Gas Properties Calculation

Characteristics	Units	WA		Vic		NSW		Tas		Qld		SA		NT		ACT	
		West Farmers	Longford	Longford	Moomba	Longford	Gladstone	Moomba	Typical	Moomba							
		NG	NG + H <sub>2</sub>	NG	NG + H <sub>2</sub>	NG	NG + H <sub>2</sub>	NG	NG + H <sub>2</sub>	NG	NG + H <sub>2</sub>	NG	NG + H <sub>2</sub>	NG	NG + H <sub>2</sub>	NG	NG + H <sub>2</sub>
Wobbe Index	MJ/m <sup>3</sup>	47.70	46.60	50.42	49.17	49.72	48.52	50.42	49.20	49.64	48.47	49.72	48.52	44.85	43.89	49.72	48.52
Relative Density	kg/kg	0.59	0.54	0.59	0.54	0.58	0.53	0.59	0.54	0.56	0.51	0.58	0.53	0.63	0.57	0.58	0.53
Higher Heating Value	MJ/m <sup>3</sup>	36.64	34.19	38.61	35.96	37.78	35.21	38.61	36.01	37.17	34.66	37.78	35.21	35.48	33.14	37.78	35.21
Maximum Total CO <sub>2</sub>	mole %	1.04	0.94	0.40	0.36	0.54	0.49	0.40	0.36	0.12	0.11	0.54	0.49	0.79	0.71	0.54	0.49
Total Inerts	mole %	4.62	4.15	1.42	1.28	1.82	1.63	1.42	1.28	1.44	1.30	1.82	1.63	9.98	8.98	1.82	1.63
Flame speed factor		13.78	16.76	14.13	17.02	14.01	16.94	14.13	17.02	13.91	16.90	14.01	16.94	13.40	16.40	14.01	16.94
Sooting index		127.29	131.97	135.72	140.74	132.92	137.82	135.72	140.61	131.71	136.50	132.92	137.82	122.17	126.71	132.92	137.82

**Table 2** National limits for combustion properties of natural gas

Characteristics	Units	National AS 4564	AEMO	WA
Minimum wobbe index	MJ/m <sup>3</sup>	46.00	46	46.50
Maximum wobbe index	MJ/m <sup>3</sup>	52.00	52	51.00
Minimum relative density	kg/kg	0.55		
Maximum relative density	kg/kg	0.70		
Minimum higher heating value	MJ/m <sup>3</sup>	37.00		37.00
Maximum higher heating value	MJ/m <sup>3</sup>	42.00	42.30	42.30
Maximum total inerts	mole %	7.00	7.00	



The comparison between the calculated combustion characteristics (Table 1) and the limits for these combustion characteristics (Table 2) show the following:

- The Wobbe number for each state is within the national standard AS 4564 and AEMO, this includes both natural gas and hydrogen blends up to 10 mole%.
- The relative density of natural gas for each state is within AS 4564, as expected. However for hydrogen blends the relative density is below the expected lower limit, with percentage differences of less than 4%. The Northern territory is the only exception and is within the AS 4564 limits.
- Higher heating values for hydrogen blends are up to 10% below the expected lower limit of 37 MJ/m<sup>3</sup> for each state.
- The Total Inerts for each state are well below both AS 4564 and AEMO, this includes both natural and hydrogen blended gases. The Northern territory is the only exception and lies outside of the 7 mole% range.
- Both flame speed and sooting index are compared to the South Australian Gas Regulations (2012) since these properties are not covered by AS 4564 and AEMO. The flame speed and sooting index are within the ± 10% of the relevant test gases referenced in AS 5263. The calculation spreadsheet in appendix 2 illustrates this as a true or false statement.
- An increase in hydrogen tends to decrease the combustion characteristics due to it being lighter and less energy dense as compared to hydrocarbons. It is important to note that the hydrogen blend combustion characteristics are all within ± 10% of the relevant test gases as per the South Australian Gas Regulations (2012).

## APPENDIX 1 HIERARCHY OF STANDARDISATION

NATIONAL	National Gas Act (2008) Modified	National Gas Act (2008)	National Gas Act (2008)	National Gas Act (2008)	National Gas Act (2008)	National Gas Act (2008)	National Gas Act (2008)	National Gas Act (2008)
		AEMO	AEMO	AEMO	AEMO	AEMO		AEMO
STATE	Gas Standards Act 1972 (WA)	Gas Act 1997 (SA)	Petroleum and Gas (Production and Safety) Act 2004 (Qld)	Gas Supply Act 1996 (NSW)	Gas Act 2000 (Tas)	Utilities Act 2000 (ACT)	National gas (NT) Act 2008	Gas Safety Act 1997 (Vic)
	Gas Standards (Gas Supply and System Safety) Regulations 2000 (WA)	Gas Regulations 2012 (SA)	Petroleum and Gas (Safety) Regulation 2018 (Qld) Petroleum and Gas (General Provisions) Regulation 2017 (Qld)	Gas Supply (Safety and Network Management) Regulation 2013 (NSW)	Gas Safety Regulations 2014 (Tas)	Utilities (Technical Regulation) Act 2014 (ACT)	Armature Gas Specification (2011)	Gas Safety (Safety Case) Regulations 2018 (Vic)
STANDARDS	AS/NZS 4645 Series – Gas Distribution Networks	AS/NZS 4645 Series – Gas Distribution Networks	AS/NZS 4645 Series – Gas Distribution Networks	AS/NZS 4645 Series – Gas Distribution Networks	AS/NZS 4645 Series – Gas Distribution Networks	AS/NZS 4645 Series – Gas Distribution Networks	AS/NZS 4645 Series – Gas Distribution Networks	AS/NZS 4645 Series – Gas Distribution Networks
	AS 4564 – Specification for Natural Gas	AS 4564 – Specification for Natural Gas	AS 4564 – Specification for Natural Gas	AS 4564 – Specification for Natural Gas	AS 4564 – Specification for Natural Gas	AS 4564 – Specification for Natural Gas	AS 4564 – Specification for Natural Gas	AS 4564 – Specification for Natural Gas
	AS 2885 – Pipelines – Gas and Liquid Petroleum	AS 2885 – Pipelines – Gas and Liquid Petroleum	AS 2885 – Pipelines – Gas and Liquid Petroleum	AS 2885 – Pipelines – Gas and Liquid Petroleum	AS 2885 – Pipelines – Gas and Liquid Petroleum	AS 2885 – Pipelines – Gas and Liquid Petroleum	AS 2885 – Pipelines – Gas and Liquid Petroleum	AS 2885 – Pipelines – Gas and Liquid Petroleum
	AS/NZS 60079 – Hazardous Area Series	AS/NZS 60079 – Hazardous Area Series	AS/NZS 60079 – Hazardous Area Series	AS/NZS 60079 – Hazardous Area Series	AS/NZS 60079 – Hazardous Area Series	AS/NZS 60079 – Hazardous Area Series	AS/NZS 60079 – Hazardous Area Series	AS/NZS 60079 – Hazardous Area Series
	WESTERN AUSTRALIA	SOUTH AUSTRALIA	QUEENSLAND	NEW SOUTH WALES	TASMANIA	AUSTRALIAN CAPITAL TERRITORY	NORTHERN TERRITORY	VICTORIA

# APPENDIX 2 CALCULATION SPREADSHEET



Document Title	Document Number	Rev
Gas Properties Calculation	19184-CALC-001	C

Scenario/Design Case Input Data				
Scenario/Design Case Name:		COAG Energy Hydrogen in the Gas		
Tag #		Units	Metric	Input
Equipment #				Calculated
Location				
P&ID #				

Input data					Scenario/Design Case Input Data																		
Description	Definition	Source	Symbol	Units	SA		QLD		VIC		NSW		WA		TAS		NT		100% H2		Test Gasses		
					Moomba	SA (+10% H2)	Gladstone	QLD (+10% H2)	Longford	VIC (+10% H2)	Moomba	NSW (+10% H2)	WPLG Plant	WA (+10% H2)	Longford	TAS (+10% H2)	Longford	Typical	NT (+10% H2)	Typical	100% H2	Test Gas Nb	Test Gas Nc
Gas Properties																							
Temperature	Assumed per AS 5263		T	C	15	15	15	15	15	15	15	15	15	15	15	15	15	15	15	15	15	15	
Pressure	Assumed per AS 5263		P	kPag	0	0	0	0	0	0	0	0	0	0	0	0	0	0	0	0	0	0	
Mass density	GPA Template19184-CALC-001B		ρ	kg/m3	0.71	0.64	0.69	0.63	0.72	0.66	0.71	0.64	0.72	0.66	0.72	0.66	0.77	0.70	0.09	0.60	0.73	0.70	
Relative Density (air)	GPA Template19184-CALC-001B				0.58	0.53	0.56	0.51	0.59	0.54	0.58	0.53	0.59	0.54	0.59	0.54	0.63	0.57	0.07	0.49	0.60	0.57	
Molar Density	GPA Template19184-CALC-001B			kg/kmol	16.72	15.25	16.23	14.81	16.99	15.49	16.72	15.25	17.10	15.69	16.99	15.52	18.13	16.52	2.02	14.22	17.24	16.50	
Wobbe Index	GPA Template19184-CALC-001B			MJ/m3	49.72	48.52	49.64	48.47	50.42	49.17	49.72	48.52	47.70	46.60	50.42	49.20	44.85	43.89	45.87	49.07	43.99	49.95	
Mass Higher Heating Value	GPA Template19184-CALC-001B		HHV	MJ/kg	53.43	54.60	54.13	55.33	53.74	54.88	53.43	54.60	50.68	51.86	53.74	54.87	46.28	47.44	141.95	57.17	46.55	54.02	
Mass Lower Heating Value	GPA Template19184-CALC-001B		LHV	MJ/kg	48.14	49.08	48.74	49.70	48.45	49.38	48.14	49.08	45.66	46.62	48.45	49.37	41.73	42.68	119.91	51.33	41.91	48.67	
Acceptable mass heating value +/-10% of test gases	LLV / HHV				TRUE / TRUE	TRUE / TRUE	TRUE / TRUE	TRUE / TRUE	TRUE / TRUE	TRUE / TRUE	TRUE / TRUE	TRUE / TRUE	TRUE / TRUE	TRUE / TRUE	TRUE / TRUE	TRUE / TRUE	TRUE / TRUE	TRUE / TRUE	FALSE / FALSE				
Molar Higher Heating Value	GPA Template19184-CALC-001B		HHV	MJ/kmol	883.22	832.50	878.76	819.50	913.01	850.35	893.22	832.50	866.41	808.37	912.99	851.45	839.04	783.70	286.15	812.89	802.44	891.52	
Molar Lower Heating Value	GPA Template19184-CALC-001B		LHV	MJ/kmol	804.76	748.45	791.16	736.22	823.13	765.02	804.78	748.45	780.57	726.88	823.11	766.03	756.60	705.06	241.72	729.79	722.45	803.08	
Volume Higher Heating Value & AS4564 check	GPA Template19184-CALC-001B		HHV	MJ/Sm3	37.78	35.21	37.17	34.66	38.81	35.96	37.78	35.21	36.64	34.19	38.61	36.01	35.48	33.14	12.10	34.38	33.94	37.70	
Volume Lower Heating Value	GPA Template19184-CALC-001B		LHV	MJ/Sm3	34.04	31.65	33.46	31.14	34.81	32.35	34.04	31.65	33.01	30.73	34.81	32.40	32.00	29.82	10.22	30.86	30.55	33.96	
Wobbe Value Assessment																							
Wobbe Index	AS 5263				-	-	-	-	-	-	-	-	-	-	-	-	-	-	-	-	49.1	44	
Wobbe Index & AS4564 check	GPA Template19184-CALC-001B				49.72	48.52	49.64	48.47	50.42	49.17	49.72	48.52	47.7	46.6	50.42	49.2	44.85	43.8863438	45.87	49.07	43.99	49.95	
Acceptable for +/-10% of test gases					TRUE	TRUE	TRUE	TRUE	TRUE	TRUE	TRUE	TRUE	TRUE	TRUE	TRUE	TRUE	TRUE	TRUE	TRUE	TRUE			
					-2.41		-2.36		-2.48		-2.41		-2.31		-2.42		-2.14						
Flame Speed Factor Assessment																							
Methane	SANS/R1			mole %	95.709	86.138	98.560	88.704	94.103	84.693	95.709	86.138	93.019	83.717	94.103	84.693	86.591	77.931	0.000	87.000	90.000	97.500	
Ethane	QLD/R2			mole %	2.389	2.132	0.000	0.000	3.965	3.588	2.389	2.132	2.349	2.114	3.965	2.215	1.993	0.000	0.000	0.000	0.000	0.000	
Propane	VIC/TAS/R3			mole %	0.071	0.064	0.000	0.000	0.444	0.399	0.071	0.064	0.016	0.014	0.444	0.399	0.712	0.640	0.000	0.000	0.000	1.000	
i-Butane	WA/R4			mole %	0.004	0.004	0.000	0.000	0.030	0.027	0.004	0.004	0.000	0.000	0.030	0.027	0.110	0.099	0.000	0.000	0.000	0.000	
n-Butane	NT/R5			mole %	0.008	0.007	0.000	0.000	0.027	0.025	0.008	0.007	0.000	0.000	0.027	0.025	0.180	0.162	0.000	0.000	0.000	0.000	
i-Pentane				mole %	0.002	0.002	0.000	0.000	0.006	0.005	0.002	0.002	0.000	0.000	0.006	0.005	0.070	0.063	0.000	0.000	0.000	0.000	
n-Pentane				mole %	0.006	0.005	0.000	0.000	0.001	0.001	0.006	0.005	0.000	0.000	0.001	0.001	0.060	0.054	0.000	0.000	0.000	0.000	
n-Hexane				mole %	0.016	0.014	0.000	0.000	0.004	0.004	0.016	0.014	0.000	0.000	0.004	0.004	0.050	0.045	0.000	0.000	0.000	0.000	
n-Heptane				mole %	0.000	0.000	0.000	0.000	0.000	0.000	0.000	0.000	0.000	0.000	0.000	0.000	0.020	0.018	0.000	0.000	0.000	0.000	
n-Octane				mole %	0.000	0.000	0.000	0.000	0.000	0.000	0.000	0.000	0.000	0.000	0.000	0.000	0.010	0.009	0.000	0.000	0.000	0.000	
n-Nonane				mole %	0.000	0.000	0.000	0.000	0.002	0.002	0.000	0.000	0.000	0.000	0.002	0.000	0.000	0.000	0.000	0.000	0.000	0.000	
Nitrogen				mole %	1.274	1.147	1.320	1.188	1.017	0.915	1.274	1.147	3.572	3.215	1.017	0.915	9.190	8.271	0.000	0.000	10.000	1.500	
Carbon Dioxide				mole %	0.541	0.487	0.120	0.108	0.402	0.362	0.541	0.487	1.043	0.939	0.402	0.362	0.792	0.713	0.000	0.000	0.000	0.000	
Hydrogen				mole %	0.000	0.000	0.000	0.000	0.000	0.000	0.000	0.000	0.000	0.000	0.000	0.000	0.000	0.000	100.000	13.000	0.000	0.000	
Flame Speed Factor					14.0	16.9	13.9	16.9	14.1	17.0	14.0	16.9	13.8	16.8	14.1	17.0	13.4	16.4	100.000	17.967	13.195	13.956	
Acceptable for +/-10% of test gases					TRUE	TRUE	TRUE	TRUE	TRUE	TRUE	TRUE	TRUE	TRUE	TRUE	TRUE	TRUE	TRUE	TRUE	TRUE	FALSE			
% Difference					+ 20.96		+ 21.46		+ 20.39		+ 20.96		+ 21.65		+ 20.39		+ 22.40						
Sooting Index Assessment																							
Sooting Index					132.92	137.82	131.71	136.50	135.72	140.74	132.92	137.82	127.29	131.97	135.72	140.61	122.17	126.71	0.00	140.30	116.68	133.91	
Acceptable for +/-10% of test gases					TRUE	TRUE	TRUE	TRUE	TRUE	TRUE	TRUE	TRUE	TRUE	TRUE	TRUE	TRUE	TRUE	TRUE	TRUE	FALSE			
% Difference					+ 3.69		+ 3.64		+ 3.70		+ 3.69		+ 3.67		+ 3.60		+ 3.72						
Tables																							

Combustible Gas Component	Flame Speed coefficient F	Air Requirement A	Sooting Coefficient B	Z (inert)	Q (oxygen)	Molar Mass	Density
Methane	148	9.55	1	0.0	0.0	16.0	0.68
Ethane	301	16.71	2	0.0	0.0	30.1	1.27
Propane	398	23.87	3.6	0.0	0.0	44.1	1.86
i-Butane	513	31.03	4.7	0.00	0.00	58.12	2.46
n-Butane	513	31.03	4.7	0.00	0.00	58.12	2.46
i-Pentane	610	38	6	0.00	0.00	72.15	3.05
n-Pentane	610	38	6	0.00	0.00	72.15	3.05
n-Hexane	710	45	10	0.00	0.00	86.18	3.64
n-Heptane	800	52	13	0.00	0.00	100.20	4.24
n-Octane	880	59	17	0.00	0.00	114.23	4.83
n-Nonane						128.26	5.42
Nitrogen	0	0	0	1.00	0.00	28.01	1.18
Carbon Dioxide	0	0	0	1.00	0.00	44.01	1.86
Hydrogen	339	2.39	0	0.00	0.00	2.02	0.09

Legend	
Visual representation of properties as per limits set out in AS 4564 (Natural Gas)	
Within range (Acceptable)	
Outside range	
Well outside range (Unacceptable)	
Check of properties as per limits set out in 2012 National Gas Act (other gases)	
TRUE	Within +/- 10% of test gases (acceptable)
FALSE	Outside +/- 10% of test gases (unacceptable)

## APPENDIX 3 GPA TEMPLATE METHODOLOGY FOR VARIOUS GAS PROPERTIES

GPA template 19184-CALC-001B uses equations from the following table to calculate the various ideal gas properties listed in section 4.1. These equations are obtained from the GPSA handbook and are the same as per the equations set out in ISO 6976.

Variable	Equation	Description
Molecular mass of gas mixture	$M_{mix} = \sum_{i=1}^N x_i \cdot M_i$	$M_{mix}$ molecular mass of the gas mixture, in kg/kmol $M_i$ molecular mass of component i, in kg/kmol $x_i$ mole fraction of component i
Specific gravity relative to air	$SG = \frac{M_{mix}}{M_{air}}$	$SG$ specific gravity (rel. dry air) $M_{mix}$ molecular mass of the gas mixture $M_{air}$ molar mass of dry air of standard composition, 28.9639 kg/kmol
Standard density	$\rho = \frac{P}{RT} \cdot M_{mix}$	$\rho$ Density of the gas mixture, in kg/std.m <sup>3</sup> $P$ Absolute standard pressure, in kPa $T$ Absolute standard temperature, in kelvin $R$ molar gas constant, 8.31447 kJ/kmol·K
Gross heating value	$GHV_v = \sum_{i=1}^N x_i \cdot GHV_i$	$GHV_v$ Gross heating value of gas mixture, in MJ/std.m <sup>3</sup> $GHV_m$ Gross heating value of gas mixture, in MJ/kg $GHV_i$ Gross heating value of component i at standard conditions, in MJ/std.m <sup>3</sup> $\rho$ Density of the gas mixture, in kg/std.m <sup>3</sup> $x_i$ mole fraction of component i
Net heating value	$GHV_m = \frac{GHV_v}{\rho}$	$NHV_v$ Gross heating value of gas mixture, in MJ/std.m <sup>3</sup> $NHV_m$ Gross heating value of gas mixture, in MJ/kg $GHV_i$ Gross heating value of component i at standard conditions, in MJ/std.m <sup>3</sup> $\rho$ Density of the gas mixture, in kg/std.m <sup>3</sup> $x_i$ mole fraction of component i
Wobbe number	$NHV_v = \sum_{i=1}^N x_i \cdot NHV_i$	$W$ Wobbe number $SG$ specific gravity (rel. dry air)
Standard conditions		$P$ Absolute standard pressure, 101.325 kPa $T$ Absolute standard temperature, 273.15K + 15K

## APPENDIX 4 NATURAL GAS COMPOSITION (MOL %)

	SA Moomba	QLD Gladstone	VIC LONGFORD	NSW MOOMBA	WA W LPG PLANT	TAS LONGFORD	NT TYPICAL
Methane	95.709	98.560	94.103	95.709	93.019	94.103	86.591
Ethane	2.369	0.000	3.965	2.369	2.349	3.965	2.215
Propane	0.071	0.000	0.444	0.071	0.016	0.444	0.712
i-Butane	0.004	0.000	0.030	0.004	0.000	0.030	0.110
n-Butane	0.008	0.000	0.027	0.008	0.000	0.027	0.180
i-Pentane	0.002	0.000	0.006	0.002	0.000	0.006	0.070
n-Pentane	0.006	0.000	0.001	0.006	0.000	0.001	0.060
n-Hexane	0.016	0.000	0.004	0.016	0.000	0.004	0.050
n-Heptane	0.000	0.000	0.000	0.000	0.000	0.000	0.020
n-Octane	0.000	0.000	0.000	0.000	0.000	0.000	0.010
n-Nonane	0.000	0.000	0.002	0.000	0.000	0.002	0.000
Nitrogen	1.274	1.320	1.017	1.274	3.572	1.017	9.190
Carbon Dioxide	0.541	0.120	0.402	0.541	1.043	0.402	0.792
Hydrogen	0.000	0.000	0.000	0.000	0.000	0.000	0.000

# APPENDIX 3 PRESSURE REDUCTION CALCULATION

## 1. AIM

To determine the Joule-Thomson effect of lean sales natural gas as well as hydrogen blended lean sales natural gas.

## 2. BACKGROUND

The Joule-Thomson effect describes the change in temperature of a real gas as it flows from an area of high pressure to an area of low pressure without heat transfer to and from the fluid. Natural gas experience a range of pressure drops as it travels in high pressure transmission pipelines from the production facility to city gate stations where it is then distributed at lower pressures to homes and businesses. These pressure drops can be large and potentially cause significant changes to the temperature of the natural gas which can cause complications to appliances

## 3. METHOD

In this calculation the following three cases were used to model the worst case pressure drop scenarios.

- Case 1: 15,000 kPag → 0 kPag, Transmission to Distribution.
- Case 2: 1965 kPag → 0 kPag, HP Distribution to appliance.
- Case 3: 1050 kPag → 0 kPag, MP Distribution to appliance.

A throttling device such as a valve is used to model the pressure drop in the three cases above using Petro-sim V6.2. The results from the modelling can be viewed in the Results section.

Petro-sim utilises the Peng-Robinson fluid package along with the Beggs and Brill equations to model the Joule-Thomson effect i.e. isenthalpic pressure drop across a valve.

## 4. RESULTS

Some of the main findings/trends from the results are as follows.

- As the pressure drop increases the outlet temperature of the gas decreases, with the exception of pure hydrogen. For instance Case 1 causes the largest temperature drop for all gas compositions.
- Pure hydrogen tends to warm up slightly during adiabatic expansion whilst natural gas cools down. The cooling of the natural gas upon expansion is more pronounced than the heating of hydrogen, and as such the net effect is that the NG/H<sub>2</sub> mixtures cool upon adiabatic expansion.
- The temperature drop of each NG/H<sub>2</sub> gas mixture is less than that of pure methane, due to the presence of heavier molecular species.

The isentropic Coefficient is another parameter that is important in expansion and compression of natural gas. For adiabatic expansion the isentropic coefficient is equal to the ratio of specific heat capacities  $C_p/C_v$ . Greater pressure drops result in more severe decreases in the isentropic coefficient.



Tables 1 and 2 below shows the Joule-Thomson cooling results for each case using discharge pressure of 0 kPag and an inlet temperature of 25°C. The pressure drop for each case has been defined in section 1.

**Table 1** *Joule-Thomson model results for each states gas mixture with and without 10% hydrogen injection*

	State	Temperature (H2/NG)	Temperature (NG)	Isentropic Coefficient (H2/NG)		Isentropic Coefficient (NG)	
		Outlet (°C)	Outlet (°C)	Inlet (Cp/Cv)	Outlet (Cp/Cv)	Inlet (Cp/Cv)	Outlet (Cp/Cv)
Transmission	SA/NSW	-29.69	-45.02	1.695	1.329	1.786	1.328
	QLD	-27.15	-41.54	1.683	1.333	1.767	1.331
	VIC/TAS	-31.77	-47.86	1.705	1.326	1.802	1.325
	WA	-28.80	-43.82	1.689	1.331	1.776	1.329
	NT	-28.29	-43.00	1.679	1.329	1.758	1.327
HP Distribution	SA/NSW	17.82	16.27	1.363	1.311	1.364	1.303
	QLD	18.08	16.59	1.366	1.315	1.367	1.308
	VIC/TAS	17.61	16.01	1.360	1.307	1.361	1.299
	WA	17.90	17.79	1.365	1.313	1.365	1.312
	NT	17.94	16.42	1.362	1.310	1.363	1.303
MP Distribution	SA/NSW	21.19	20.38	1.337	1.309	1.333	1.302
	QLD	21.32	20.55	1.341	1.314	1.337	1.306
	VIC/TAS	21.08	20.25	1.333	1.305	1.329	1.297
	WA	21.23	21.17	1.338	1.311	1.338	1.311
	NT	21.25	20.46	1.336	1.309	1.332	1.301

Note - 1 Natural gas and hydrogen blended natural gas compositions for each state are obtained from document 19184-CALC-001-rC. These compositions can also be viewed in appendix 1 of this document.

**Table 2** *Joule-Thomson model results for pure Hydrogen and Methane*

Gas	Case	Temperature	Isentropic Coefficient	
		Outlet (°C)	Inlet (Cp/Cv)	Outlet (Cp/Cv)
Pure CH <sub>4</sub>	Transmission	-42.21	1.773	1.330
	HP Distribution	16.54	1.367	1.307
	MP Distribution	20.52	1.336	1.306
Pure H <sub>2</sub>	Transmission	29.95	1.444	1.414
	HP Distribution	25.48	1.419	1.414
	MP Distribution	25.25	1.417	1.414

## APPENDIX 1 GAS COMPOSITIONS

### Appendix 1A Natural Gas Composition (mole %)

	SA Moomba	QLD Gladstone	VIC LONGFORD	NSW MOOMBA	WA W LPG PLANT	TAS LONGFORD	NT TYPICAL
Methane	95.709	98.560	94.103	95.709	93.019	94.103	86.591
Ethane	2.369	0.000	3.965	2.369	2.349	3.965	2.215
Propane	0.071	0.000	0.444	0.071	0.016	0.444	0.712
i-Butane	0.004	0.000	0.030	0.004	0.000	0.030	0.110
n-Butane	0.008	0.000	0.027	0.008	0.000	0.027	0.180
i-Pentane	0.002	0.000	0.006	0.002	0.000	0.006	0.070
n-Pentane	0.006	0.000	0.001	0.006	0.000	0.001	0.060
n-Hexane	0.016	0.000	0.004	0.016	0.000	0.004	0.050
n-Heptane	0.000	0.000	0.000	0.000	0.000	0.000	0.020
n-Octane	0.000	0.000	0.000	0.000	0.000	0.000	0.010
n-Nonane	0.000	0.000	0.002	0.000	0.000	0.002	0.000
Nitrogen	1.274	1.320	1.017	1.274	3.572	1.017	9.190
Carbon Dioxide	0.541	0.120	0.402	0.541	1.043	0.402	0.792
Hydrogen	0.000	0.000	0.000	0.000	0.000	0.000	0.000

Note - 1 Natural gas compositions obtained from GPA document 19184-CALC-001-rC.

**Appendix 1B**

**Hydrogen/Natural Gas Fuel Blend Composition (mole %)**

	<b>SA Moomba</b>	<b>QLD Gladstone</b>	<b>VIC LONGFORD</b>	<b>NSW MOOMBA</b>	<b>WA WLP PLANT</b>	<b>TAS LONGFORD</b>	<b>NT TYPICAL</b>
Methane	86.138	88.704	84.693	86.138	83.717	84.693	77.931
Ethane	2.132	0.000	3.568	2.132	2.114	3.568	1.993
Propane	0.064	0.000	0.399	0.064	0.014	0.399	0.640
i-Butane	0.004	0.000	0.027	0.004	0.000	0.027	0.099
n-Butane	0.007	0.000	0.025	0.007	0.000	0.025	0.162
i-Pentane	0.002	0.000	0.005	0.002	0.000	0.005	0.063
n-Pentane	0.005	0.000	0.001	0.005	0.000	0.001	0.054
n-Hexane	0.014	0.000	0.004	0.014	0.000	0.004	0.045
n-Heptane	0.000	0.000	0.000	0.000	0.000	0.000	0.018
n-Octane	0.000	0.000	0.000	0.000	0.000	0.000	0.009
n-Nonane	0.000	0.000	0.002	0.000	0.000	0.002	0.000
Nitrogen	1.147	1.188	0.915	1.147	3.215	0.915	8.271
Carbon Dioxide	0.487	0.108	0.362	0.487	0.939	0.362	0.713
Hydrogen	10.000	10.000	10.000	10.000	10.000	10.000	10.000

Note - 1 Hydrogen/natural gas fuel blend compositions obtained from GPA document 19184-CALC-001-rC.

## APPENDIX 2 PETRO-SIM MODEL AND DATA

### Appendix 2A Petro-sim Model (Natural Gas)

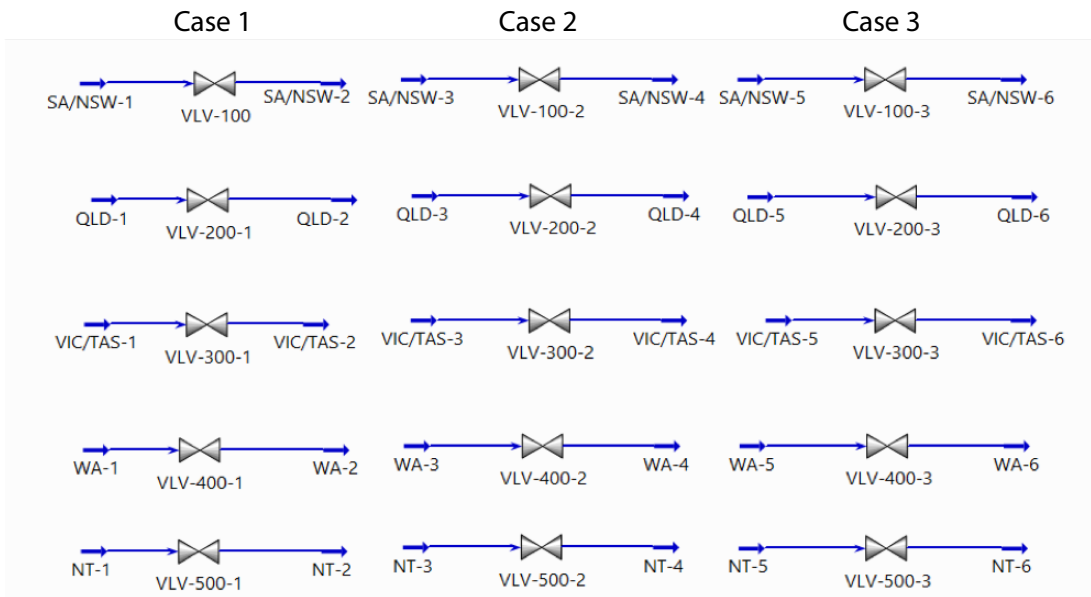

### Appendix 2B Petro-sim Model (Hydrogen Blended Natural Gas)

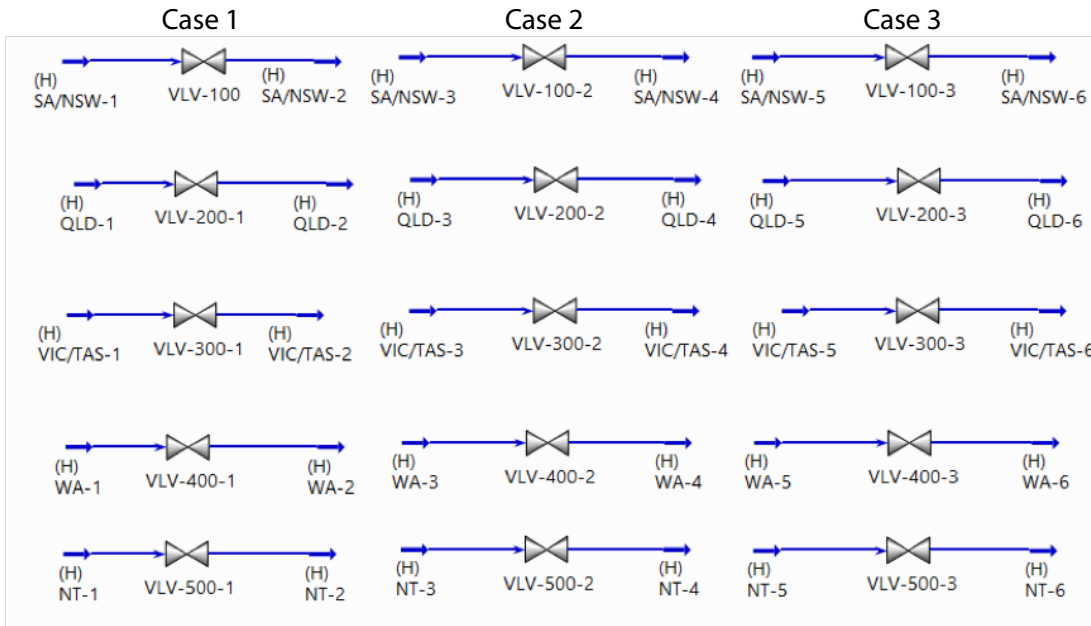

### Appendix 2C Petro-sim Model (Methane and Hydrogen)

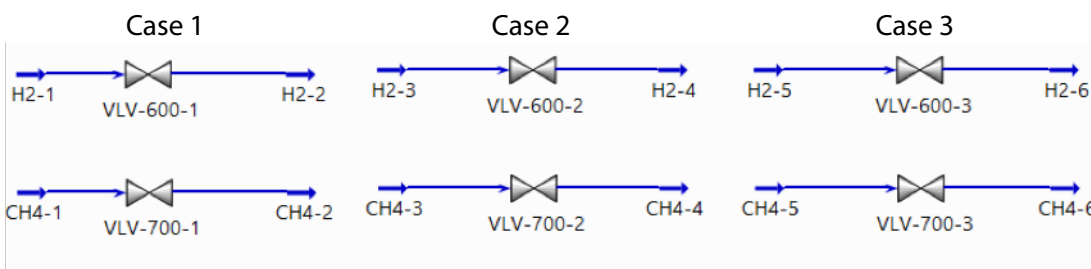

## Appendix 2D Petro-sim Data for All Streams

Name	Temperature °C	Pressure kPa(g)	Cp/Cv	Name	Temperature °C	Pressure kPa(g)	Cp/Cv
H2-1	25.00	15000	1.444	QLD-2-4	-41.54	0	1.331
H2-2	29.95	0	1.414	QLD-3-4	25.00	1965	1.367
H2-3	25.00	1965	1.419	QLD-4-4	16.59	0	1.308
H2-4	25.48	0	1.414	QLD-5-4	25.00	1050	1.337
H2-5	25.00	1050	1.417	QLD-6-4	20.55	0	1.306
H2-6	25.25	0	1.414	VIC/TAS-1-3	25.00	15000	1.802
CH4-1	25.00	15000	1.773	VIC/TAS-2-3	-47.86	0	1.325
CH4-2	-42.21	0	1.330	VIC/TAS-3-3	25.00	1965	1.361
CH4-3	25.00	1965	1.367	VIC/TAS-4-3	16.01	0	1.299
CH4-4	16.54	0	1.307	VIC/TAS-5-3	25.00	1050	1.329
CH4-5	25.00	1050	1.336	VIC/TAS-6-3	20.25	0	1.297
CH4-6	20.52	0	1.306	(H) WA-1	25.00	15000	1.689
(H) SA/NSW-1	25.00	15000	1.695	(H) WA-2	-28.80	0	1.331
(H) SA/NSW-2	-29.69	0	1.329	(H) WA-3	25.00	1965	1.365
(H) SA/NSW-3	25.00	1965	1.363	(H) WA-4	17.90	0	1.313
(H) SA/NSW-4	17.82	0	1.311	(H) WA-5	25.00	1050	1.338
(H) SA/NSW-5	25.00	1050	1.337	(H) WA-6	21.23	0	1.311
(H) SA/NSW-6	21.19	0	1.309	(H) NT-1	25.00	15000	1.679
(H) QLD-1	25.00	15000	1.683	(H) NT-2	-28.29	0	1.329
(H) QLD-2	-27.15	0	1.333	(H) NT-3	25.00	1965	1.362
(H) QLD-3	25.00	1965	1.366	(H) NT-4	17.94	0	1.310
(H) QLD-4	18.08	0	1.315	(H) NT-5	25.00	1050	1.336
(H) QLD-5	25.00	1050	1.341	(H) NT-6	21.25	0	1.309
(H) QLD-6	21.32	0	1.314	WA-1-3	25.00	15000	1.776
(H) VIC/TAS-1	25.00	15000	1.705	WA-2-3	-43.82	0	1.329
(H) VIC/TAS-2	-31.77	0	1.326	WA-3-3	25.00	1965	1.365
(H) VIC/TAS-3	25.00	1965	1.360	WA-4-3	17.79	0	1.312
(H) VIC/TAS-4	17.61	0	1.307	WA-5-3	25.00	1050	1.338
(H) VIC/TAS-5	25.00	1050	1.333	WA-6-3	21.17	0	1.311
(H) VIC/TAS-6	21.08	0	1.305	NT-1-3	25.00	15000	1.758
SA/NSW-1	25.00	15000	1.786	NT-2-3	-43.00	0	1.327
SA/NSW-2	-45.02	0	1.328	NT-3-3	25.00	1965	1.363
SA/NSW-3	25.00	1965	1.364	NT-4-3	16.42	0	1.303
SA/NSW-4	16.27	0	1.303	NT-5-3	25.00	1050	1.332
SA/NSW-5-4	25.00	1050	1.333	NT-6-3	20.46	0	1.301
SA/NSW-6-4	20.38	0	1.302	TAS	15.00	0	1.304
QLD-1-4	25.00	15000	1.767	NSW	15.00	0	1.312

## APPENDIX 4 FEEDSTOCK PROCESSES

**Table 21** Processes using natural gas as a feedstock

Industry	Summary
Metal	<p>Iron and steel production: Currently steel is produced from iron ore via a reaction with coking coal in a blast furnace. This reaction allows for the removal of oxygen from the ore. A similar reduction reaction can occur using hydrogen; with an electric arc furnace used to produce the steel. Although, a potentially very significant role for hydrogen, the CSIRO states that it is unlikely to occur before 2030 due to current technology maturity and a small amount of coal would still be required to make steel because steel is an alloy of iron and carbon.</p> <p>Aluminium production: use gas for power generation and for refining bauxite to produce alumina, which is used to produce aluminium. Currently natural gas is the only fuel that can achieve the required temperature.</p>
Chemical	<p>Ammonia as feedstock for several industries such as making fertilisers (urea), explosives, cleaning products and also in fermentation</p> <p>Nitric Acid production</p> <p>Titanium dioxide production</p> <p>Antifreezes: hydrofluorocarbon production (for substituting ozone depleting substances)</p> <p>Methanol for building products, paints and resins, pigments and dyes, carpeting, adhesives, agricultural chemicals, biodiesel and agents for the treatment of sewage and waste water</p>
Mineral	<p>Cement / lime production</p> <p>Ceramic production</p> <p>Brick production</p> <p>Minerals processing, such as sodium cyanide for gold extraction and processing</p>
Other Production	<p>Food processing, fermentation, winemaking and brewing (where ammonia is a feedstock)</p> <p>Synthetic fuel manufacturing</p> <p>Glass manufacturing</p> <p>Petrochemical sector - Plastic production in e.g. food packaging and wrapping, plumbing and piping for both water and gas service, fibres and textiles, machine parts. Plastics are made from ethane, which is derived from natural gas, by adding steam to crack ethane to produce ethylene, a plastics feedstock.</p> <p>Sulphur hexachloride (used in electrical switchgear)</p>



**Hydrogen in the Gas Distribution Networks**  
*A kickstart project as an input into the development  
of a National Hydrogen Strategy for Australia*

Prepared by  
GPA Engineering for the Government of South Australia  
in partnership with Future Fuels CRC  
on behalf of the COAG Energy Council.

GPA Document No: 19184-REP-001



**COAG**  
Energy Council



**GPA**  
ENGINEERING



Government  
of South Australia